



Preview - Information



**Thank you for your interest in this bundle.
Within this preview, you will see:**

- ✓ **A selection of worksheets included in each workbook. Keep scrolling to find the next resource included in the bundle.**

When you make a purchase, you will receive a folder with the .pdf workbook files inside.

Thank you for shopping with us. Please let us know if you have any questions at:

rob@supersimplesheets.com

Grade 8
Strand: B1. Number Sense

	Curriculum Expectations	Pages That Cover the Expectations
B1.1	represent and compare very large and very small numbers, including through the use of scientific	9 - 19
B1.2		
B1.3	estimate and calculate square roots, in various contexts	20 - 44
B1.4	use fractions, decimal numbers, and percents, including percents of more than 100% or less than 1%, interchangeably and flexibly to solve a variety of problems	58 - 83

**Preview of 120 pages from
this product that contains
442 pages total.**

Name: _____

6

Curriculum Link: 3.1

Place Value – How Many...

Number	Trillions	Billions	Millions	Thousands	Ones
136 489 121 879 845	136	489	121	879	845

Part 1

How many of each are the numbers made up of? Fill in the table below

Number	Trillions	Billions	Millions	Thousands	Ones
1) 851					
2) 63 24					
3) 649 07 845					
4) 846 843 013 2					
5) 515 036 468 043 966					
6) 456 876 800 451 035					
7) 610 098 690 649 049					
8) 46 584 867 704 674					
9) 311 049 007 876 004					
10) 400 004 085 749 886					

Part 2

Answer the questions below

1)	How many hundreds are in one-thousand?	
2)	How many thousands are in one-million?	
3)	How many millions are in one-billion?	
4)	How many billions are in one-trillion?	
5)	Challenge: How many millions are in one-trillion?	

Scientific Notation – Power of 10

Powers of 10 are used to make it easier to write larger numbers. Using powers of 10 allows us to write less zeros than we normally would. $563000 = 5.63 \times 10^5$

For example:

$5,000 = 5 \times 1,000$ or using powers of 10, you can say $5,000 = 5 \times 10^3$

The 3 is called an exponent. The exponent shows how many places the decimal has moved.

Part 1

Write the value for the exponents below

	Standard Notation	Using the Power of 10
1)	1 000 000	$1 \times 10^{\square}$
2)	100 000	$1 \times 10^{\square}$
3)	10 000	$1 \times 10^{\square}$
4)	10 000 000	$1 \times 10^{\square}$
5)	1 250 000 000	$1.25 \times 10^{\square}$
6)	5 458 000 000	$5.458 \times 10^{\square}$
7)	7 030 800 000 000	$7.0308 \times 10^{\square}$
8)	30 8900 000 000 000	$3.089 \times 10^{\square}$
9)	527 200 000 000 000	$5.272 \times 10^{\square}$
10)	651 454 460 000 000	$6.5145446 \times 10^{\square}$

Part 2

Kaylee made mistakes in her homework. Write the correct answer for her

	Standard Notation	Kaylee's Answer	Correct Answer
1)	652 000 000	$652 \times 10^{\square}$	
2)	13 300 000 000	$133 \times 10^{\square}$	
3)	853 120 000 000	$85312 \times 10^{\square}$	

Exit Cards

Cut Out

Cut out the exit cards below and have students complete them at the end of class

Name: _____

1) Fill in the value for the exponents below.

	Standard Notation	Scientific Notation
1)	60 000	$6 \times 10^{\square}$
2)	700 000	$7 \times 10^{\square}$
3)	8 000 000	$8 \times 10^{\square}$

2) Write the scientific notation of the numbers below.

	Standard Notation	Scientific Notation
1)	1 000 000	
2)	3 200 000 000	
3)	713 308 000 000	

Name: _____

1) Fill in the value for the exponents below.

	Standard Notation	Scientific Notation
1)	60 000	$6 \times 10^{\square}$
2)	700 000	$7 \times 10^{\square}$
3)	8 000 000	$8 \times 10^{\square}$

2) Write the scientific notation of the numbers below.

	Standard Notation	Scientific Notation
1)	1 000 000	
2)	3 200 000 000	
3)	713 308 000 000	

Scientific and Standard Notation

Questions

What is the scientific expanded notation of the numbers below?

1) 6 753 501 003

$$(6 \times 10^9) + (7 \times 10^8) + (5 \times 10^7) + (3 \times 10^6) + (5 \times 10^5) + (1 \times 10^4) + (3 \times 10^3)$$

2) 3 432 730

3) 17 128 000

4) 38 018

5) 7 20

6) 5 308 020

7) 26 040 012 600

8) 105 030 007 805

9) 340 062 700 080

10) 9 040 502 020 500

PREVIEW

Comparing Numbers – Scientific Notation

Part 1

Which number is larger? Use $>$ or $<$ to compare the numbers.

1)	3×10^6	<input type="text"/>	4×10^6	6)	5×10^{-4}	<input type="text"/>	6×10^{-4}
2)	3×10^7	<input type="text"/>	6×10^7	7)	1.8×10^{-2}	<input type="text"/>	4.21×10^{-2}
3)	7.1×10^5	<input type="text"/>	7×10^5	8)	6×10^{-9}	<input type="text"/>	7.5×10^{-9}
4)	3.6×10^3	<input type="text"/>	4×10^3	9)	2.2×10^{-6}	<input type="text"/>	2.1×10^{-6}
5)	9.14×10^2	<input type="text"/>	9.22×10^2	10)	10^{-8}	<input type="text"/>	3.66×10^{-8}

Part 2

Answer the word problems below.

1) The population in China is 1.398×10^8 . The population of the United States is 3.282×10^8 . Which country has the larger population?



2) The distance from Earth to Mercury is 9.16×10^7 km. The distance from Earth to Venus is 4.14×10^8 km. Which planet is further from Earth?



3) The approximate wavelength of red light is 7×10^{-7} metres. The approximate wavelength of ultraviolet light is 4×10^{-8} metres. Which wavelength is longer?



Place Value – Number Breakdown

Questions

Fill in the blanks below

Number Breakdown

400 005 020 200 302

Tens	Billions	Millions	Thousands	Ones

Fill in the blank and write in scientific notation below:

$$(\quad \times 10^{\square}) + (\quad \times 10^{\square}) + (\quad \times 10^{\square}) + (\quad \times 10^{\square}) + (\quad \times 10^{\square})$$

Fill in the pattern below

$$400\,005\,020\,200\,302, \quad 400\,025\,020\,200\,302, \quad 400\,045\,020\,200\,302, \quad \dots$$

Fill in the pattern below

$$400\,005\,020\,200\,302, \quad 400\,005\,024\,200\,302, \quad 400\,005\,028\,200\,302, \quad \dots$$

Fill in the pattern below

$$400\,005\,020\,200\,302, \quad 410\,005\,020\,200\,302, \quad 415\,005\,020\,200\,302, \quad \dots$$

400 005 020 200 302	+ 1 000 000	
400 005 020 200 302	+ 1 000 010 000	
400 005 020 200 302	+ 100 001 000 010 000	
400 005 020 200 302	- 1 010 000 000	
400 005 020 200 302	- 100 000 001 000 100	

Place Value Quiz

Part 1

Which place value is the underlined number?

1) 875 315 465 8622) 764 846 413 211 9843) 5 651 215 183 1654) 794 85 188 8935) 32 161 984 634 5166) 2 487 256 881 254**Part 2**

Fill in the blank - how many are in the number?

	Number	Billions	Millions	Thousands	Ones
1)	92 504 812 158 185				
2)	258 184 586 021 648				
3)	807 515 033 665 485				

Part 3

Write the scientific notation of the number below.

	Standard Notation	Scientific Notation
1)	100 000	
2)	1 200 000	
3)	345 300 000	
4)	875 300 000 000	
5)	0.5480000	
6)	0.05700000	
7)	0.0068700000	

Part 4

What is the standard form of the numbers below?

1) $(4 \times 10^4) + (2 \times 10^3) + (3 \times 10^2) + (5 \times 10^1) + (7 \times 10^0) + (8 \times 10^{-1})$

2) $(5 \times 10^5) + (9 \times 10^4) + (4 \times 10^3) + (4 \times 10^2) + (7 \times 10^1) + (2 \times 10^0) + (3 \times 10^{-1})$

3) $(2 \times 10^6) + (5 \times 10^5) + (4 \times 10^4) + (7 \times 10^3) + (9 \times 10^2) + (3 \times 10^1)$

Part 5

Write the standard form of the numbers below using powers of 10

1) 2 851 460 000

2) 5 005 430 301

Part 6

Write the standard notation of the written form below

1) Eight trillion, two hundred forty-billion, one-million, twenty-seven thousand, three.

2) Seventy-three trillion, two hundred thirty-three billion, one.

Part 7

Write the written form of the standard notation below

1) 40 500 802 300

2) 104 001 301 000 800

Perfect Squares – Square Numbers

A **perfect square** is any number that is a product of two identical numbers. In other words, when we multiply two of the same numbers together, the answer is a perfect square. Perfect squares are also referred to as square numbers.

Examples –

9 is a perfect square (3×3)

4 is a perfect square (2×2)

Part 1

Solve by determining the perfect square

	Question	Perfect Square
1)	$1 \times 1 =$	
2)	$2 \times 2 =$	
3)	$3 \times 3 =$	
4)	$4 \times 4 =$	
5)	$5 \times 5 =$	
6)	$6 \times 6 =$	

	Question	Perfect Square
7)	$7 \times 7 =$	
8)	$8 \times 8 =$	
9)	$9 \times 9 =$	
10)	$10 \times 10 =$	
11)	$11 \times 11 =$	
12)	$12 \times 12 =$	

Part 2

Solve the word problem below

- 1) Richard built a square deck. One of the side lengths is 9m. What is the area of the deck?

- 2) The area of a square tile is 121cm^2 . What are the side lengths?

Exit Cards

Cut Out

Cut out the exit cards below and have students complete them at the end of class

Name: _____

1) Find out the area of the squares below

	Perfect Square
1)	
2)	$8 \times 8 =$
3)	$11 \times 11 =$
4)	$13 \times 13 =$

2) The area of a square tile is 196cm^2 . What are the side lengths?

Name: _____

1) Find out the area of the squares below

	Question	Perfect Square
1)	$7 \times 7 =$	
2)	$8 \times 8 =$	
3)	$11 \times 11 =$	
4)	$13 \times 13 =$	

2) The area of a square tile is 196cm^2 . What are the side lengths?

Name: _____

1) Find out the area of the squares below

	Question	Perfect Square
1)	$7 \times 7 =$	
2)	$8 \times 8 =$	
3)	$11 \times 11 =$	
4)	$13 \times 13 =$	

2) The area of a square tile is 196cm^2 . What are the side lengths?

Name: _____

1) Find out the area of the squares below

	Question	Perfect Square
1)	$7 \times 7 =$	
2)	$8 \times 8 =$	
3)	$11 \times 11 =$	
4)	$13 \times 13 =$	

2) The area of a square tile is 196cm^2 . What are the side lengths?

Area of a Squares – Square Root





When we calculate the area of a square, we use a square number to determine the area.

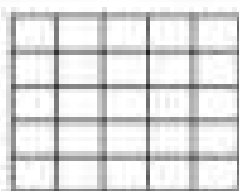
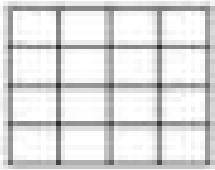

If the area of a square is 9, its side length is $\sqrt{9}$ or 3.

Part 1

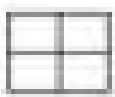
What is the area? Write the side lengths as square roots and units

	Area	Side Length		Question	Area	Side Length
1)		_____ units	4)			_____ units $\sqrt{\quad}$
2)		_____ units $\sqrt{\quad}$	5)			_____ units $\sqrt{\quad}$
3)		_____ units $\sqrt{\quad}$	6)			_____ units $\sqrt{\quad}$

Part 2

Fill in the table

	Area	Side Length (Units)	Side Length
1)			$\sqrt{64}$
2)		7	$\sqrt{\quad}$
3)	144		$\sqrt{\quad}$
4)		11	$\sqrt{\quad}$

Part 3

Is the number a perfect square?

	Area	Yes/No
1)	17	
2)	81	
3)	42	
4)	100	

Perfect Squares – Exponents

When we multiply a number by itself, we can use an exponent. An **exponent** refers to the number of times a number is multiplied by itself. A **perfect square** is the square of an integer. This means it is the number that is the product of two equal factors. Therefore, it is when we use an exponent to the power of 2.



Example – 16 is a perfect square (4×4) or 4^2

Part 1 _____ by determining the perfect square

	Question	Perfect Square
1)	1^2	
2)	2^2	
3)	3^2	
4)	4^2	
5)	5^2	
6)	6^2	

	Question	Perfect Square
7)	7^2	
8)	8^2	
9)	9^2	
10)	10^2	
11)	11^2	
12)	12^2	

Part 2 Find out the area of the squares below

When we calculate the area of a square, we are multiplying the length by the width or base times height. Since a square has the same side lengths, the formula is: s^2

	Question	Area
1)	6cm	
2)	13cm	

	Question	Area
3)	7mm	
4)	9m	

Square Roots

A square root is a number that can be multiplied by itself to give the original number. A square root is the opposite of a perfect square. Instead of multiplying a number by itself, we take the answer and find out what number was used.

Each positive number has two possible square roots – one positive and one negative

Example The square roots of 49 are +7 and -7 because $(+7)(+7)$ and $(-7)(-7) = 49$

Part 1 Find the positive and negative square root

	Question	Answer	Question	Square Root	
				(+)	(-)
1)	$\sqrt{36}$		7)	$\sqrt{49}$	
2)	$\sqrt{4}$		8)	$\sqrt{25}$	
3)	$\sqrt{9}$		9)	$\sqrt{16}$	
4)	$\sqrt{16}$		10)	$\sqrt{81}$	
5)	$\sqrt{121}$		11)	$\sqrt{100}$	
6)	$\sqrt{144}$		12)	$\sqrt{64}$	

Part 2 Provide the square root based on the symbol used

The symbol $\sqrt{\quad}$ means positive square root and the symbol $\pm\sqrt{\quad}$ means provide both the positive and negative square roots.

	Question	Answer(s)
1)	$\pm\sqrt{81}$	
2)	$\sqrt{49}$	
3)	$\pm\sqrt{9}$	

	Question	Answer(s)
4)	$\pm\sqrt{36}$	
5)	$\sqrt{100}$	
6)	$\pm\sqrt{64}$	

Perfect Squares - Word Problems

Word Problems

Answer the word problems below

- 1) Which whole numbers between 100 and 150 are perfect squares?
- 2) Which whole numbers between 150 and 200 are perfect squares?
- 3) I am a square number. The sum of my digits is 7. What square numbers might I be?
- 4) What three square numbers have a sum that is a square number?
- 5) Archer is planning to make a square garden this year. He needs to have an area less than 50m^2 .
 - a) What is the largest area the garden could be?
 - b) What is the side length of the garden?
 - c) How many metres of fencing will be needed?
 - d) If one metre of fencing costs Archer \$2.50, how much would the entire fence cost him?



PREVIEW

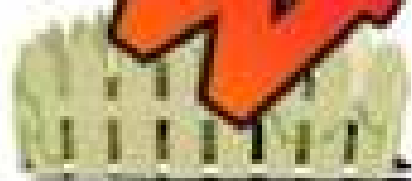



Exit Cards

Cut Out

Cut out the exit cards below and have students complete them at the end of class

Name: _____

1) Find out the area of the squares below

Question	Area
 5cm	
	

2) What two square numbers have digits that add up to 13?

Name: _____



1) Find out the area of the squares below

Question	Area
 5cm	
 12m	

2) What two square numbers have digits that add up to 13?

Name: _____

1) Find out the area of the squares below

Question	Area
 5cm	
 12m	

2) What two square numbers have digits that add up to 13?

Name: _____

1) Find out the area of the squares below

Question	Area
 5cm	
 12m	

2) What two square numbers have digits that add up to 13?

Rational vs Irrational Numbers

A rational number can be written as a ratio of two integers (a simple fraction). If a decimal number has a repeating or terminating decimal, it is a rational number.

Examples

5 can be written as $\frac{5}{1}$

$\sqrt{16}$ can be written as 4 ($\frac{4}{1}$)

0.333... can be written as $\frac{1}{3}$

An irrational number cannot be written as a ratio of two integers. Another clue is that the decimal goes on forever without repeating.

Examples

π (3.14159...)

$\sqrt{2} = 1.414213562373095...$

$\sqrt{10} = 3.162277660168379...$

Part 1

Number rational or irrational?

	Question	Rational/Irrational
1)	$\sqrt{18}$	
2)	9	
3)	$\frac{5}{8}$	
4)	$\sqrt{16}$	
5)	$2\bar{5}$	
6)	$\sqrt{24}$	

	Question	Rational/Irrational
7)	$\sqrt{49}$	
8)	8	
9)	$\frac{1}{2}$	
10)	$\frac{2}{6}$	
11)	$\frac{2}{6}$	
12)	$\sqrt{72}$	

Part 2

Write at least 10 rational and irrational numbers below

Rational Numbers

Irrational Numbers

Terminating and Repeating Decimal

Terminating Decimal

- Decimals that come to an end

Example - $\frac{2}{4} = 0.5$

Repeating Decimal

- Decimals that never end

Example - $\frac{2}{3} = 0.66666\dots$ or $0.\overline{6}$

We can use a line over the repeating number or number pattern to show it repeats forever.

Part 1 Write each decimal as a repeating or terminating decimal?

1) 0.6	6) 0.9
2) 0.3	7) $0.\overline{72}$
3) $0.\overline{7}$	8) $0.41\overline{5}$
4) 0.25	9) 1.8
5) $0.\overline{6}$	

Part 2 Write the decimals below - use a line over the repeating digits.

1) $\frac{1}{3} = 0.\overline{3}$	2) $\frac{6}{10} =$	3) $\frac{1}{2} =$
4) $\frac{2}{3} =$	5) $\frac{8}{11} =$	6) $\frac{3}{9} =$
7) $\frac{1}{4} =$	8) $\frac{11}{12} =$	9) $\frac{4}{12} =$
10) $\frac{3}{5} =$	11) $\frac{4}{6} =$	12) $\frac{1}{12} =$
13) $\frac{5}{8} =$	14) $\frac{1}{8} =$	15) $\frac{7}{8} =$

Estimating Square Roots

Perfect squares can be calculated. Imperfect squares can only be estimated.

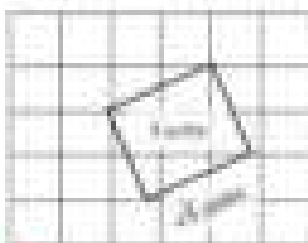
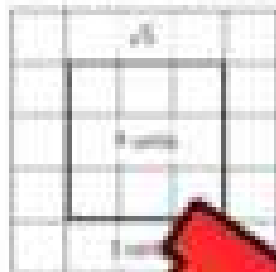

An imperfect square and its square root is an irrational number with a decimal number that never ends.

We can estimate a square root by determining the two perfect squares that are closest to it.

Example: $\sqrt{31}$ is between $\sqrt{25}$ and $\sqrt{36}$, which means it is in between 5 and 6. This means that the square of $\sqrt{31}$ is around 31. Since 31 is closer to 36 than 25, the answer should be 5.6.

Practice

Estimate the square root of the numbers below by filling in the table

	Non-Perfect Square	Lower Perfect Square	Higher Perfect Square	Estimate	Calculate round to tenth
1)	$\sqrt{19}$	$\sqrt{16} = 4$	$\sqrt{25} = 5$	4.4	4.4
2)	$\sqrt{42}$				
3)	$\sqrt{68}$				
4)	$\sqrt{91}$				
5)	$\sqrt{29}$				
6)	$\sqrt{13}$				
7)	$\sqrt{55}$				
8)	$\sqrt{73}$				
9)	$\sqrt{6}$				
10)	$\sqrt{130}$				

Estimating Square Roots - Colouring

Practice

Find the two square roots between the irrational numbers and colour the picture with the matching colour.

	Irrational Number	Square Root 1	Square Root 2	Colour
1)	$\sqrt{32}$	$\sqrt{\quad}$	$\sqrt{\quad}$	Light Green
2)	$\sqrt{11}$	$\sqrt{\quad}$	$\sqrt{\quad}$	Yellow
3)	$\sqrt{7}$	$\sqrt{\quad}$	$\sqrt{\quad}$	Purple
4)	$\sqrt{2}$	$\sqrt{\quad}$	$\sqrt{\quad}$	Green
5)	$\sqrt{17}$	$\sqrt{\quad}$	$\sqrt{\quad}$	Light Green
6)	$\sqrt{49}$	$\sqrt{\quad}$	$\sqrt{\quad}$	Dark Green
7)	$\sqrt{54}$	$\sqrt{\quad}$	$\sqrt{\quad}$	Yellow
8)	$\sqrt{8}$	$\sqrt{\quad}$	$\sqrt{\quad}$	Dark Green
9)	$\sqrt{152}$	$\sqrt{\quad}$	$\sqrt{\quad}$	Green
10)	$\sqrt{84}$	$\sqrt{\quad}$	$\sqrt{\quad}$	Dark Green

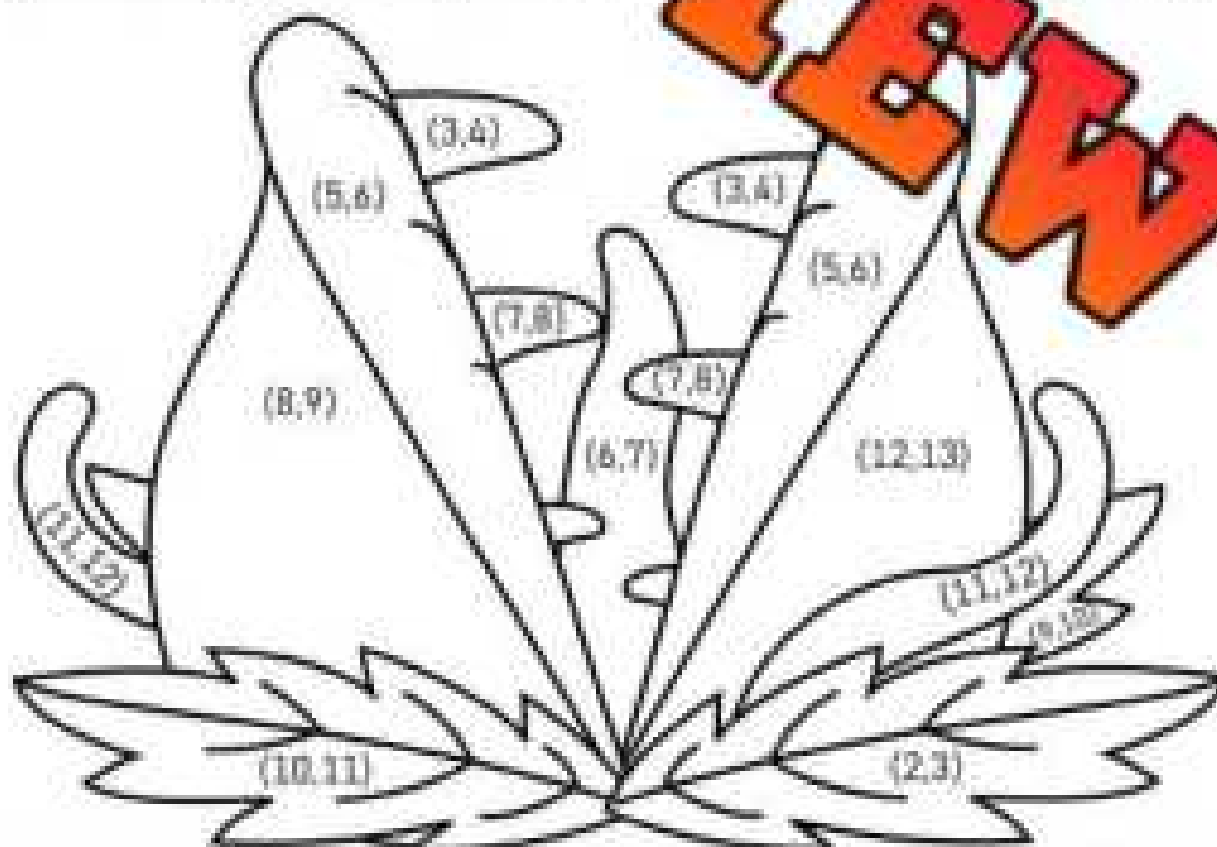

Estimating Square Roots - Riddle

Practice

Find the lower and higher perfect squares and write the corresponding letter above the numbers below

	Non-Perfect Square	Lower Perfect Square	Higher Perfect Square
B	$\sqrt{11}$		
Z			
S			
R	$\sqrt{55}$		
A	$\sqrt{2}$		
A	$\sqrt{6}$		
A	$\sqrt{77}$		
D	$\sqrt{125}$		
E	$\sqrt{18}$		

What's black and white and blue

(64,81)

(81,100)

(4,9)

(121,144)

(36,49)

(16,25)

(9,16)

(49,64)

(1,4)

Estimating Square Roots

Step 1: Find the two perfect squares above and below the irrational number.

Step 2: Use the following formula to find the decimal number that will go with the whole number. Simplify the fraction.

Irrational Number Lower Perfect Square
Bigger Perfect Square Lower P.S.

Step 3: Change the fraction using the lower perfect square to a decimal number. Simplify the fraction from Step 2.

Step 4: Change the decimal number to a decimal number (rounded to the nearest hundredth).

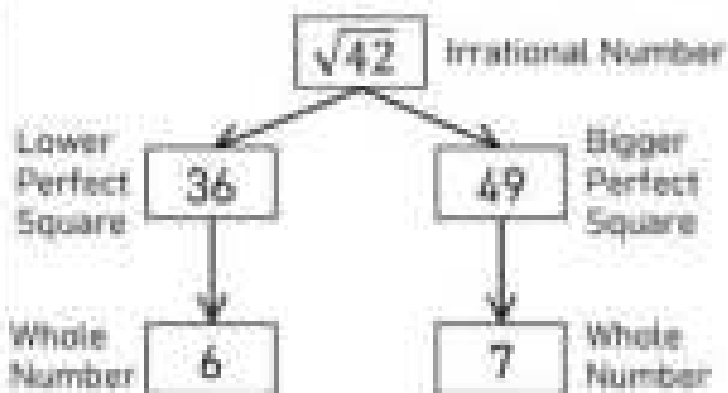

$$\frac{42 - 36}{49 - 36} = \frac{6}{13}$$

$$= 6 \frac{6}{13} \text{ or } 6.46$$

Practice

Fill in the blanks by following the steps above.

$\sqrt{19}$

$\sqrt{68}$

$\sqrt{28}$

$\sqrt{57}$

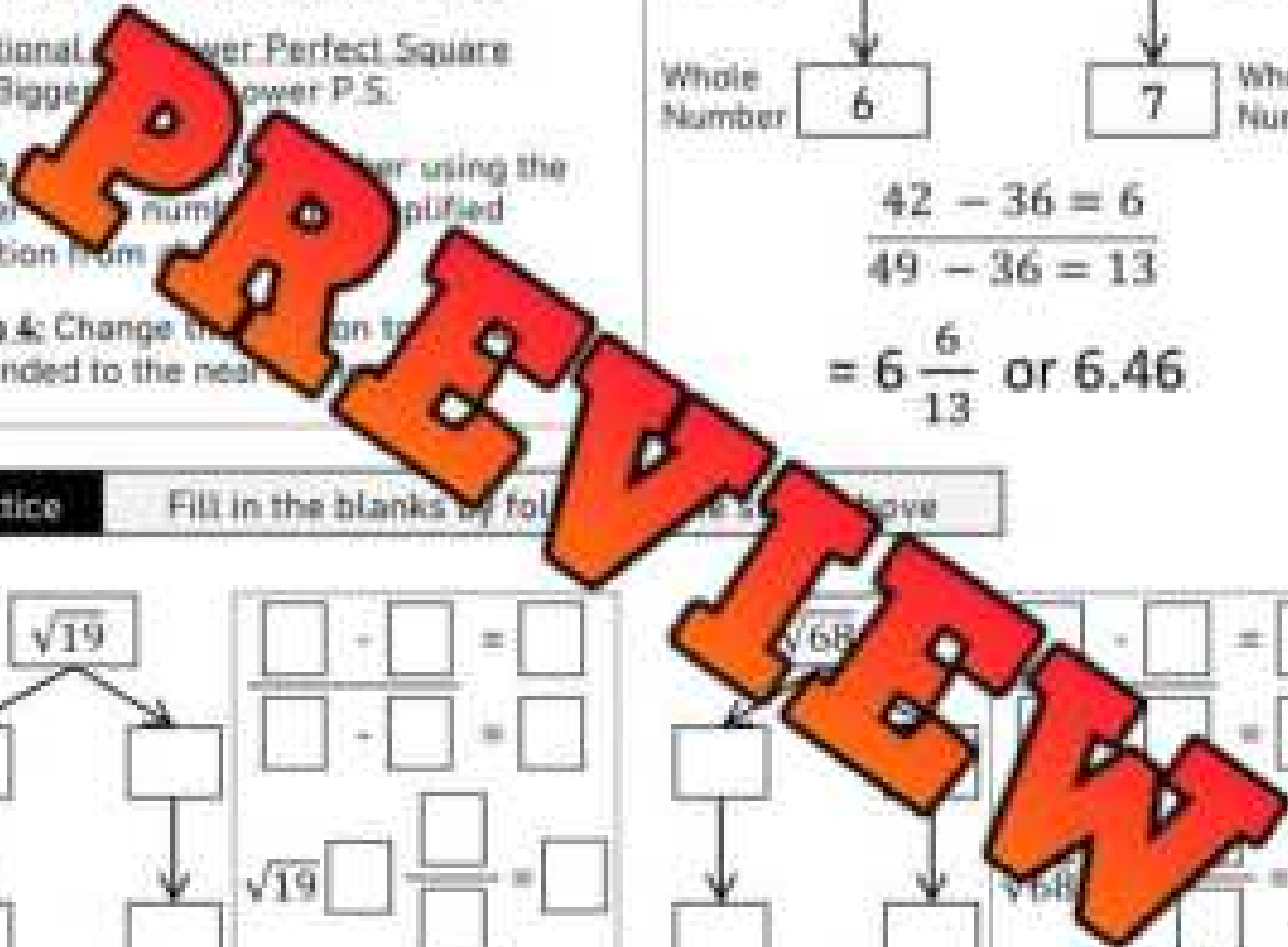

Comparing Square Roots & Perfect Squares

Part 1

Which number is larger? Use $>$, $=$ or $<$ to compare the numbers

1)	3^2	<input type="text"/>	$\sqrt{110}$		6)	$\sqrt{45}$	<input type="text"/>	7
2)		<input type="text"/>	10		7)	$\sqrt{7}$	<input type="text"/>	3
3)	5		8		8)	$\sqrt{14}$	<input type="text"/>	3
4)	7				9)	12	<input type="text"/>	$\sqrt{138}$
5)	$\sqrt{29}$	<input type="text"/>				11	<input type="text"/>	$\sqrt{127}$

Part 2

Order from least to greatest

1) $\sqrt{8}$, 2 , $\sqrt{10}$, 3 , $\sqrt{5}$	3) $\sqrt{82}$, 8 , 10 , 9
2) $\sqrt{32}$, $\sqrt{41}$, -11 , 6 , $\sqrt{35}$	4) $\sqrt{140}$, 12 , $\sqrt{147}$, 11 , 13

Part 3

Circle which numbers are imperfect squares

1) 25 , 4 , 12 , 24 , 36 , 50 , 100 , 68 , 56 , 64 , 88 , 96 , 1 , 6 , 20
2) 16 , 10 , 28 , 35 , 9 , 0 , 81 , 144 , 110 , 108 , 121 , 64 , 62 , 18

Square Roots – Number Line

Part 1 Place each square root on the number line to show its approximate value

1) $\sqrt{38}$

2) $\sqrt{10}$

3) $\sqrt{28}$

4) $\sqrt{42}$

5) $\sqrt{65}$

6) $\sqrt{87}$



7) $\sqrt{62}$

8) $\sqrt{10}$

9) $\sqrt{132}$

10) $\sqrt{141}$

11) $\sqrt{98}$

12) $\sqrt{22}$



Part 2 Which value is larger? Use $>$, $<$ or $=$ to compare the values.

1) 5 $\sqrt{21}$

4) 8.5 $\sqrt{66}$

7) 7.5 $\sqrt{52}$

2) 3 $\sqrt{14}$

5) 9.5 $\sqrt{95}$

8) 12.5 $\sqrt{145}$

3) 6 $\sqrt{31}$

6) 7.5 $\sqrt{60}$

9) 11.5 $\sqrt{142}$

Exit Cards

Cut Out Cut out the exit cards below and have students complete them at the end of class

Name: _____

1) Which value is larger?

a) 4 $\sqrt{20}$

b) 9 $\sqrt{85}$

2) Order from least to greatest

$\sqrt{50}$, 8 , $\sqrt{60}$, 7 , $\sqrt{48}$

Name: _____

1) Which value is larger?

a) 4 $\sqrt{20}$

b) 9 $\sqrt{85}$

2) Order from least to greatest

$\sqrt{50}$, 8 , $\sqrt{60}$, 7 , $\sqrt{48}$

Name: _____

1) Which value is larger?

a) 4 $\sqrt{20}$

b) 9 $\sqrt{85}$

2) Order from least to greatest

$\sqrt{50}$, 8 , $\sqrt{60}$, 7 , $\sqrt{48}$

Name: _____

1) Which value is larger?

a) 4 $\sqrt{20}$

b) 9 $\sqrt{85}$

2) Order from least to greatest

$\sqrt{50}$, 8 , $\sqrt{60}$, 7 , $\sqrt{48}$



Square Roots - Word Problems

Word Problems

Answer the word problems below.

1) Jade painted a beautiful square painting. She would like to frame it, so she needs the dimensions of the sides. The area of the painting is 5m^2 . What are the side lengths? Round to the nearest two decimal places.



2) Weston is creating a fence around his square yard. The area of his yard is 140m^2 .

a) What are the side lengths? Round to the nearest hundredth?

b) The fencing comes in metre lengths. How many metres should he buy?



3) Livia made a rectangular painting for her friend. The area of the painting is 24cm^2 . Livia's friend loves it but needs a square painting to fit the space. If Livia recreates a square painting with the same area, what should the side lengths be?



4) An estimate for a square root is 8.49. Is the whole number (square) closer to 64 or 81? Explain.

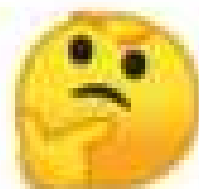

Introduction to Integers

Integers are whole numbers that can be positive, negative or zero. Integers do not include fractions or decimals. We use positive integers a lot, but we sometime need to use negative integers, like when we are measuring the temperature outside in the winter.

Questions

Use the number lines to solve the questions.

1) The temperature at 6am was -9°C . At noon, the temperature was 5°C . Circle the temperature on the number line. How much did the temperature rise?



Rise in temperature = _____

2) Steve was in debt to his brother. He had to pay him back $-\$5$. He was able to make some money by cutting his neighbor's grass and gave his brother back and has $\$10$ left. How much did he make cutting grass?



Earnings from cutting grass = \$ _____

3) A running back in football earned -8 yards in the first half of his game with 10 yards. How many yards did he get in the second half?



Yards in the second half = _____

4) Tiger Woods scored a -8 in his third round of a golf tournament. He scored $+8$ in the fourth round. How many more shots did he take in the fourth round?



Extra shots in the fourth round = _____

Writing Integers

We can represent a situation using integers. In cases where we have less than zero, we can use a negative integer. When we have more than zero, we use a positive integer.

Example - Kaitlyn owes her father \$20. Therefore, Kaitlyn has $-\$20$.

Questions

Write the integer for the situation below

1) Hank withdrew \$50 from his bank account. Write the change of his bank account as an integer.

2) A submarine plunged 132m below sea level. Write this as an integer.



3) The average temperature in October is -11°C . Write an integer that shows the temperature drop from July to October.

4) The world's coldest temperature ever recorded was 89°C below zero. Write this as an integer.

5) Mount Logan is the highest mountain in Canada with a peak of 5,959m above sea level.



6) A football player ran 17 yards on the field. Write this number as an integer.



7) Savana played a great round of golf, shooting 7 strokes below par. What is her golf score as an integer?



8) Hyker lost \$850 with a bad investment. Write his loss as an integer.



9) Bailey took 15 steps forwards and 27 steps backwards. Write how many steps she moved as an integer.

10) Nathan paid \$15 the last 3 months for his Netflix account. Write how much he paid as an integer.

Comparing Integers



Part 1

Use the $<$, $>$, $=$ to compare the integers below

- 1) 9 -3 2) -7 3 3) -10 0
- 4) -2 9 5) 1 -1 6) -10 10
- 7) -3 3 8) -5 5 9) 8 -6
- 10) -6 -7 11) -7 -1 12) 1 0

Part 2

Arrange the integers from least to greatest

- | | |
|-------------------------|-----------------------|
| 1) $7, 2, -6, -7, 4$ | 2) $0, -4, -8, 8$ |
| 3) $0, 3, -4, 5, -6$ | 4) $-2, 0, -6, 2, -5$ |
| 5) $10, -10, -9, 8, -8$ | 6) $-8, -7, 7, 0, 8$ |

Representing Integers as Fractions

Integers are rational numbers that can be represented as fractions. We can represent positive and negative whole numbers as fractions by putting the integer on top of the number 1.

For example: $-5 = \frac{-5}{1}$ and $+9 = \frac{9}{1}$.

Part 1 Fill in the tables below

	Integer	Fraction
1)	-2	
2)		
3)		
4)	9	
5)		$\frac{2}{1}$

	Integer	Fraction
6)	-7	
7)		$\frac{-6}{1}$
8)	5	
		$\frac{3}{1}$
10)		

Part 2 Word problems

- Sienna pays \$60 each month for her phone bill. Represent her total bill for a year as an integer and as a fraction.
- Reagan is filling up her pool with water. Each hour, 100 litres is poured into the pool. Represent how many litres of water poured into the pool after 24 hours as an integer and a fraction.
- A submarine plunged 64m below sea level. It plunged another 49m before coming back up. Represent how many metres below sea level the submarine was as an integer and a fraction.

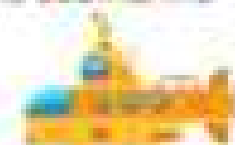

Proper Fractions – Number Line

A **proper fraction** has a numerator (top number) smaller than the denominator (bottom number). When we place a proper fraction on a number line, it will always fall between 0 and 1.



Example - Plotting $\frac{1}{2}$ and $\frac{-1}{2}$ on a number line

- 1) The denominator tells us how many equal parts are between 0 and 1
- 2) The numerator tells us how many parts starting from zero we move to plot our fraction
- 3) $\frac{1}{2}$ corresponds with $\frac{-1}{2}$ which means the same steps will work for both

Practice plotting fractional numbers on the number lines below



Put in order from least to greatest: _____



Put in order from least to greatest: _____



Put in order from least to greatest: _____

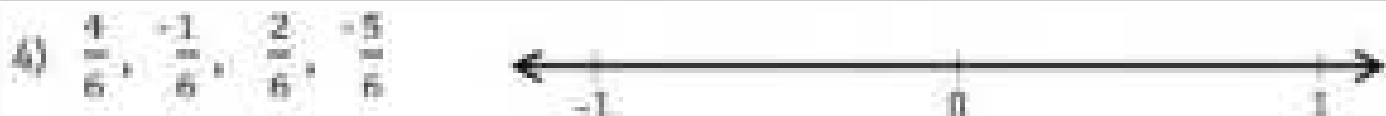

Put in order from least to greatest: _____

Improper Fractions – Number Line

An **improper fraction** has a numerator greater than the denominator. This means there are more parts than the whole, which means we have a mixed number.

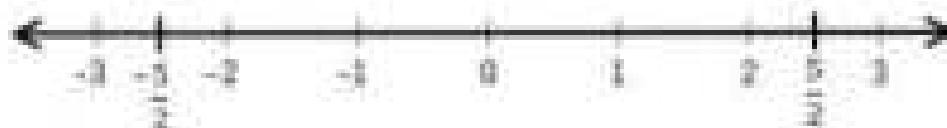

Example - plotting $\frac{5}{4}$ and $\frac{9}{4}$ on a number line

- 1) Convert the improper fraction to a mixed number: $\frac{5}{4} = 2\frac{1}{4}$
- 2) Use the whole number you get from your conversion and the next whole number as the number to plot on your number line (2 and 3)
- 3) The denominator of the mixed number tells us how many equal parts we need between 2 and 3
- 4) The numerator tells us how many parts starting from zero we move to plot our fraction
- 5) $\frac{5}{4}$ corresponds to $2\frac{1}{4}$ so the same steps will work for both

Practice

Plot the fractions on the number lines below

1) $\frac{5}{3}, \frac{-5}{3}, \frac{4}{3}, \frac{-4}{3}$

Put in order from least to greatest: _____

2) $\frac{9}{4}, \frac{-9}{4}, \frac{11}{4}, \frac{-11}{4}$

Put in order from least to greatest: _____

3) $\frac{14}{6}, \frac{-14}{6}, \frac{17}{6}, \frac{-17}{6}$

Put in order from least to greatest: _____

Comparing Rational Numbers – Fractions/Integers

Part 1

Use the $<$, $>$, $=$ to compare the integers below

1) $\frac{6}{8}$ $\frac{5}{4}$

5) $\frac{3}{6}$ $\frac{-5}{10}$

9) $\frac{6}{2}$ $\frac{9}{4}$

2) $\frac{3}{4}$ $\frac{-2}{1}$

6) $\frac{9}{1}$ $\frac{8}{1}$

10) $\frac{2}{10}$ $\frac{10}{2}$

3) $\frac{0}{9}$ $\frac{0}{9}$

7) $\frac{-5}{6}$ $\frac{-5}{4}$

11) $\frac{-6}{1}$ $\frac{-5}{1}$

4) $\frac{-4}{2}$ $\frac{0}{2}$

8) $\frac{0}{4}$ $\frac{4}{4}$

12) $\frac{-15}{3}$ $\frac{-10}{5}$

Part 2

Arrange the numbers from least to greatest

1) $\frac{6}{2}$, -5 , $\frac{-12}{2}$, $\frac{16}{4}$, 2 , $\frac{-4}{2}$, -7

2) $\frac{9}{2}$, -4 , $\frac{-11}{2}$, $\frac{15}{5}$, 4 , $\frac{-5}{1}$, -6

4) $\frac{14}{3}$, 4 , $\frac{-15}{4}$, $\frac{20}{4}$, -3 , $\frac{-20}{10}$, 8

5) $\frac{11}{3}$, 2 , $\frac{18}{2}$, $\frac{-21}{7}$, 8 , $\frac{-19}{7}$, -8

Exit Cards

Cut Out

Cut out the exit cards below and have students complete them at the end of class

Name: _____

1) Which value is larger?

a) $-\frac{8}{7}$ $-\frac{9}{5}$

b) $\frac{6}{6}$ $\frac{8}{6}$

2) Order from least to greatest

$-\frac{3}{4}, -2, -\frac{1}{2}, 7, \frac{7}{2}, 3$

Name: _____

1) Which value is larger?

a) $-\frac{8}{7}$ $-\frac{9}{5}$

b) $\frac{6}{6}$ $\frac{8}{6}$

2) Order from least to greatest

$-\frac{3}{4}, -2, -\frac{1}{2}, 7, \frac{7}{2}, 3$

Name: _____

1) Which value is larger?

a) $-\frac{8}{7}$ $-\frac{9}{5}$

b) $\frac{6}{6}$ $\frac{8}{6}$

2) Order from least to greatest

$-\frac{3}{4}, -2, -\frac{1}{2}, 7, \frac{7}{2}, 3$

Name: _____

1) Which value is larger?

a) $-\frac{8}{7}$ $-\frac{9}{5}$

b) $\frac{6}{6}$ $\frac{8}{6}$

2) Order from least to greatest

$-\frac{3}{4}, -2, -\frac{1}{2}, 7, \frac{7}{2}, 3$

Comparing Rational Numbers – Decimals/Integers

Part 1

Plot the decimal numbers and integers on the number line

1) 0, -2, 1.5, -1.5, 2, 2.5, -2.5



2) 1, -1.5, -1.25, 2, -2, 2.75, -2.75



3) 3, -2.25, 2.5, 2.75, -2.75



4) 2.5, -3.75, 2.25, 3.5, -3.25

Part 2

Put the integers and decimal numbers in order from least to greatest

1) -7, -7.412, 7, 7.39, 2^2

2) -3, 2.984, -3.031, 3.012, 3^2

3) 11.72, 11.26, -11.21, -11.37

4) 9.63, -9.63, 9.63, -9.63

5) 21.35, 21.53, -5^2 , -3^2 , 3.747

6) 2^2 , -2^2 , -8.107, 8.01, 0

PREVIEW

Class List - Decimal, Fraction, Percent

Mrs. Hansen just finished marking a math test. Her class list with the results of the test are below. She has simplified some of the fractions, and some students wrote a different test, meaning they are out of a different total.

Grades
 A = 80% and up
 B = 70% - 79%
 C = 60% - 69%
 D = 50% - 59%
 E = 49% or less



Questions

Fill in the class list

Student	Mark	Decimal	Percent	Grade
Madison				
River	7/100			
Parker				
Zara	14/20			
Lorenzo	1/2			
Damian	1/7			
Matteo	5/5			
Everly	2/5			
Evan	79.5/100			
Skylar	93.5/100			
Luka	9.5/12			
Josie	2.5/9			
Cora	2/10			
Kaylee	3.5/5			
Savannah	75			

Percents Greater Than 100

Percentages are out of 100. In other words, 100% is 100/100. In some cases, it may be impossible to get over 100%. For example, you can't watch TV more than 100% of your time. This is impossible because 100% is all the time you have.

On the other hand, it is very possible to have percentages over 100%. For example, you may get 100% of the vitamin C you need from eating an orange. But suppose you ate 3 oranges. You would receive 300% of the vitamin C you need for the day.



Part 1 Fill in the table using fractions out of 100

Fraction	Decimal	Percent
105/100	1.05	105.0%
150/100		
		400.0%
510/100		
	7.02	
900.5/100		

Part 2 Fill in the table using fractions out of 1000

Fraction	Decimal	Percent
2005/1000	2.005	200.5%
		301%
	3.582	
4486/1000		
		672.3%
	8.08	
10500/1000		

Percents Greater Than 100

Situations can be described as over 100% when we can define what 100 means. For example, an athlete can give more than 100% when we define 100% as how much effort they can give for an entire game. There may be times during the game where the athlete can give 110% when they can rest at 90% during another time.

Part 1

Write your own scenarios that would result in over 100%

	Scenario Using More Than 100%
Ex 1	My friend scored 10 points and I scored 20. I scored 200% more points than Rodi.
Ex 2	There was 20% more rainfall in April as there was in March.
1)	
2)	
3)	
4)	
5)	

Part 2

Does the scenario make sense?

	Scenario	Yes or No
1)	My workday is 8 hours. I worked 120% of a workday today	
2)	120% of the world's population has been sick at least once	
3)	125% of the sky is covered in clouds	
4)	My investment of \$100 has grown 300%	
5)	There was one birthday cake, and I ate 150% of it!	
6)	The teacher marked 110% of the tests she received.	
7)	You got 110% on a test because you answered the bonus question	
8)	You sold 20 drinks in the morning and 200% more in the afternoon	

Sport Statistics – Fractions, Decimals, and Percents

Questions

Basketball Statistics - Shooting Percentages



1) Pascal Siakam played power forward for the Toronto Raptors in 2021. His shooting percentages for the 2021 season are listed in the table below.

	2 pointers	3 pointers	Free Throws
Fraction	$437/961$	$73/246$	$249/301$
Decimal			
Percent			

a) If Siakam had taken 1000 two pointers, how many would he have made?

b) If Siakam had taken 1000 three pointers, how many would he have made?

c) If Siakam had taken 500 free throws, how many would he have made?

d) If Siakam took 500 three pointers, how many would he have made?

2) OG Anunoby played small forward for the Toronto Raptors in 2021. His shooting percentages for the 2021 season are listed in the table below.

	2 pointers	3 pointers	Free Throws
Fraction	$249/519$	$104/261$	$249/301$
Decimal			
Percent			

a) If OG had only taken 100 free throws, how many would he have made?

b) If OG had taken 850 free throws, how many would he have made?

c) If OG had taken 650 three pointers, how many would he have made?

d) If OG had taken 1000 three pointers, how many would he have made?

Fractions, Decimals, and Percents - Word Problems

Questions

Answer the word problems below

1) Finn scored 82% on a math test. Aspen scored $20/25$ on the same test. Who received a higher percentage?



2) Gracie and Blakely all ran for student president. Gracie received 35% of the 200 votes and 0.31 of the votes and Blakely received $68/200$ votes.

How many votes did each student get?

Gracie	Geet	Blakely

3) Daisy's goal is to walk 10,000 steps each day. Today she walked 9253 steps. What percentage of her goal did she reach?

4) Tyler's investment of \$100 gained \$10. He had an increase of $10/100$. What percentage has his investment increased?

5) Zayden and his friend Norah drove 500km to Canada's Wonderland. Zayden drove 335km and Norah drove the rest.

- What percentage of the trip did Zayden drive?
- What percentage of the trip did Norah drive?

6) Arthur can throw a football 66 yards. A Canadian football field is 110 yards. What percentage of the football field can Arthur throw?



Exit Cards

Cut Out

Cut out the exit cards below and have students complete them at the end of class.

Name: _____

1) Fill in the table with the converted decimal, fraction, and percent

Fraction	Decimal	Percent
		95%
$62.5/100$		
	0.4	

2) Lucas scored $18/20$ on a science test, while Emma scored 85% on the same test. Who received a higher percentage?

Name: _____

1) Fill in the table with the converted decimal, fraction, and percent

Fraction	Decimal	Percent
		95%
$62.5/100$		
	0.4	

2) Lucas scored $18/20$ on a science test, while Emma scored 85% on the same test. Who received a higher percentage?

Name: _____

1) Fill in the table with the converted decimal, fraction, and percent

Fraction	Decimal	Percent
		95%
$62.5/100$		
	0.4	

2) Lucas scored $18/20$ on a science test, while Emma scored 85% on the same test. Who received a higher percentage?

Name: _____

1) Fill in the table with the converted decimal, fraction, and percent

Fraction	Decimal	Percent
		95%
$62.5/100$		
	0.4	

2) Lucas scored $18/20$ on a science test, while Emma scored 85% on the same test. Who received a higher percentage?

Name: _____

75

Equivalent Fractions
100%**Percents Greater Than 100****Part 1**

Fill in the table

	Fraction	Decimal	Percent
1)	$1\frac{1}{2}$	1.50	150%
2)	$2\frac{1}{4}$		
3)		3.50	
4)			475%
5)	1		
6)			750%
7)		.25	

Part 2

Convert the fractions to a decimal

	Fraction	Decimal
1)	25/20	
2)	50/25	
3)	88/50	
4)	125/100	
5)	200/150	
6)	300/200	
7)	475/325	

Fractions, Decimals, Percents – Word Problems

Questions

Answer the word problems below

1) Kylie bakes cakes and sells them. It costs her \$5 to make a cake. She sells the cake for \$18. What percentage is the selling price in comparison to the cost price?



2) Gavin earned \$40 an hour. He received a raise from his boss and is now earning \$60 an hour. How many times does Gavin earn now in relation to what he earned before the raise?



3) Maeve did well on her test. She got the 20 questions correct and answered 3 bonus questions. Write her mark as a fraction and percentage?

Fraction

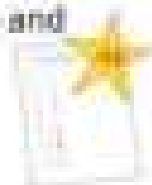

4) Elliott ran a 10km race last week. The winner finished in 30 minutes. It took Elliot 45 minutes. What percentage of the winner's time did Elliott take in relation to the winner's time?



5) Calvin sold a baseball card for \$88. He bought it for \$20. How much did Calvin sell it for in relation to what he paid as a percentage?



6) Luke hit the golf ball 200 yards. Scott drove the golf ball 300 yards right after. Write how much further Scott hit the ball than Luke as a fraction, decimal, and percent.

Fraction	Decimal	Percent



Name: _____

III

Numbers Sense Quiz

Part 1

Provide the positive and negative square root

	Question	Square Root	
		(+)	(-)
1)	$\sqrt{25}$		
2)	$\sqrt{16}$		
3)	$\sqrt{81}$		

	Question	Square Root	
		(+)	(-)
4)	$\sqrt{121}$		
5)	$\sqrt{25}$		
6)	$\sqrt{64}$		

Part 2

Which number is greater or = to compare the number

1)	5^2	<input type="checkbox"/>	$\sqrt{100}$
2)	$\sqrt{64}$	<input type="checkbox"/>	7
3)	$\sqrt{49}$	<input type="checkbox"/>	2^3

4)	$\sqrt{121}$	<input type="checkbox"/>	11^2
5)	$\sqrt{81}$	<input type="checkbox"/>	-6
6)	-50	<input type="checkbox"/>	$\sqrt{100}$

Part 3

Order from least to greatest

1) $\sqrt{49}$, 49, $\sqrt{16}$, -16, $\sqrt{9}$, $\sqrt{81}$	3) $\sqrt{16}$, 16, $\sqrt{64}$, -1, $\sqrt{100}$
2) $\sqrt{144}$, $\sqrt{36}$, -6, 6, $\sqrt{121}$	4) $\sqrt{9}$, 4, $\sqrt{81}$, 10, $\sqrt{4}$

Part 4

Is the number a rational or irrational number?

	Question	Rational/Irrational
1)	$\sqrt{24}$	
2)	9	
3)		

	Question	Rational/Irrational
4)	$\sqrt{49}$	
5)	$0.\bar{3}$	
6)	$\sqrt{10}$	

Part 5

Find the square roots of the numbers below by filling in the table

	Non-Perfect Squares	Two Square Roots	Estimate	Calculate round to tenth
1)	$\sqrt{20}$			
2)	$\sqrt{10}$			
3)	$\sqrt{6}$			
4)	$\sqrt{30}$			

Part 6

Plot the rational numbers on the number line below

1) $\frac{1}{3}, -\frac{1}{3}, \frac{2}{3}, -\frac{2}{3}$



Put in order from least to greatest: _____

2) $\frac{7}{3}, -\frac{7}{3}, \frac{11}{3}, -\frac{11}{3}$



Put in order from least to greatest: _____

Part 7

Use the $<$, $>$, $=$ to compare the integers below

1) $\frac{6}{8}$ <input type="text"/> $\frac{5}{4}$	2) $\frac{5}{9}$ <input type="text"/> $\frac{10}{18}$	3) $\frac{6}{2}$ <input type="text"/> $\frac{9}{4}$
4) $\frac{3}{4}$ <input type="text"/> $\frac{-2}{1}$	5) $\frac{9}{1}$ <input type="text"/> $\frac{8}{1}$	6) $\frac{-15}{3}$ <input type="text"/> $\frac{-10}{5}$

Part 8

What fraction, decimal and percent of the array is shaded in?

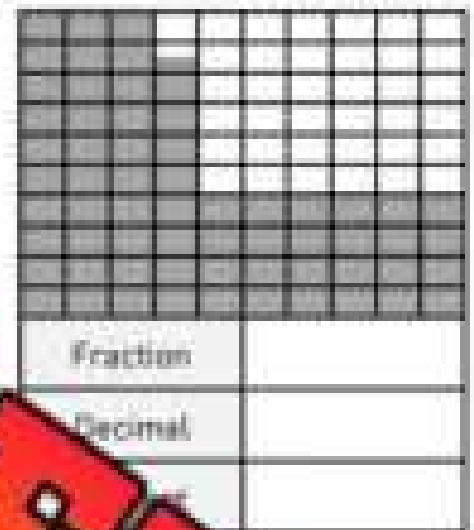
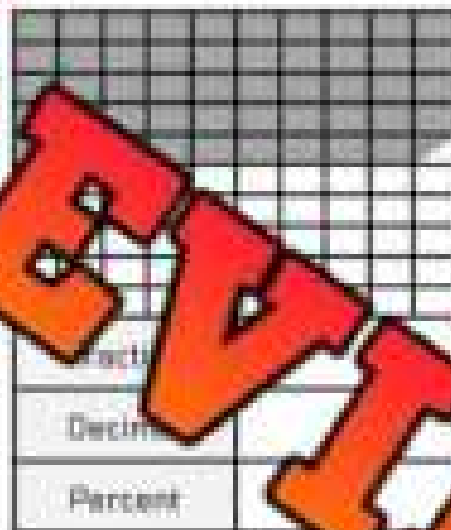
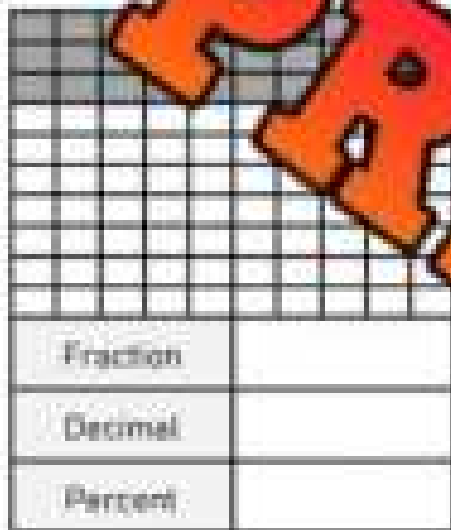

Part 9

Convert the fractions to a decimal and percent.

	Fraction	Decimal	Percent
1)	$\frac{68}{100}$		
2)	$\frac{30}{20}$		
3)	$\frac{60}{20}$		
4)	$3\frac{3}{4}$		
5)	$2\frac{1}{4}$		
6)	$\frac{8}{3}$		

Part 10

Answer the word problems below

1) John's investment of \$200 gained \$40. His return as a fraction is $\frac{40}{200}$. What percentage has his investment increased?



2) Felicia makes cookies and sells them. It costs her \$1 to make a cookie. She sells each cookie for \$1.50. What percentage is the selling price in comparison to the cost price?

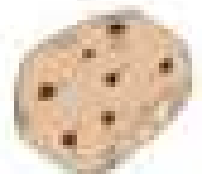

3) Jonah earns \$25 an hour. He received a raise in his salary and is now earning \$45 an hour. What percentage does Jonah earn now in comparison to what he earned before the raise?



4) Sienna did well on her math test. She got all of the 50 questions correct and answered 5 bonus questions correct as well. What was her mark as a fraction and percentage?

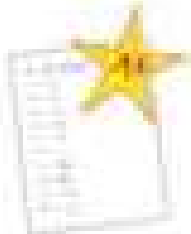

Grade 8

Strand: B2. Operations

	Curriculum Expectations	Pages That Cover the Expectations
B2.1	use the properties and order of operations, and the relationships between operations, to solve problems involving rational numbers, ratios, rates, and percents, including those requiring multiple steps or multiple operations	85 – 89, 99, 132 – 138
B2.2	understand and recall commonly used square numbers and their square roots	90 – 98
B2.3	use mental math strategies to multiply and divide whole numbers and decimal numbers up to thousandths by powers of ten, and explain the strategies used	100 – 105
B2.4	add and subtract integers, using appropriate strategies, in various contexts	106 – 116
B2.5	add and subtract fractions, using appropriate strategies, in various contexts	139 – 167
B2.6	multiply and divide fractions by fractions, as well as by whole numbers and mixed numbers, in various contexts	168 – 205
B2.7	multiply and divide integers, using appropriate strategies, in various contexts	117 – 131
B2.8	compare proportional situations and determine unknown values in proportional situations, and apply proportional reasoning to solve problems in various contexts	206 – 222

Mixed Operations - BEDMAS

When solving an equation, you need to follow the order of operations. This means you have to solve the equation in the correct order, not just from left to right. Using BEDMAS helps us remember the order to solve.

1. Brackets 2. Exponents 3. Division or Multiplication (whichever is first)
4. Addition or Subtraction (whichever is first)

Example 2

$$12 - 3 + (3 \times 1)$$

$$12 - 3 + 3$$

$$12 - 1 = 11$$

Questions

Solve the equations using BEDMAS

1) $7 + (5 \times 7)$

3) $(8 \times 6) + (4 + 2)$

4) $36 \div 6 \times 4$

5) $11 + 3 \times 10 - (2 + 3)$

7) $48 \div 6 \times (4 + 10) - 7$

8) $52 - 12 \times 3$

9) $50 + (3 \times 11) - 12$

10) $35 - 15 \div 5 + 25$

11) $42 - 5 \times 3 + 32$

12) $(8 - 3)(3 \times 2)$

Order of Operations – Who's Right?

Questions

Quinn and Alex both answered the questions below. Circle who's right.

	Question	Quinn's Answer	Alex's Answer
1	$8 + 4 \times 4 + 16$	40	64
2	$12 \div 3 + 13$	39	103
3	16×3	48	3
4	$15 \times 2 + 3$	21	36
5	$48 + 8 \times (7 + 4)$	66	46
6	$81 + 9 + (8 - 3 \times 2)$	11	99
7	$10(15 - 2 \times 5 - 2)$	30	30
8	$(25 - 20)6(1 + 2)$	33	90
9	$(66 + 6) - (2 + 3 \times 2)$	3	1
10	$5 + 4 \times 8 + 12 - 8 - 2$	38	45

Comparing Two Quantities

Part 1

Use the $<$, $=$, $>$ to make the statements true.

1) $8 + 7 \times 2$ <input style="width: 40px; height: 25px;" type="text"/> $9 + 2 \times 5$	6) $25 - 7 \times 3$ <input style="width: 40px; height: 25px;" type="text"/> $\frac{x^2}{9} + 2$
2) $11 -$ <input style="width: 40px; height: 25px;" type="text"/> $7 \times 7 - 20$	7) $3^2 + 9 \times 4$ <input style="width: 40px; height: 25px;" type="text"/> $48 - 22 \times 2$
3) 15×2 <input style="width: 40px; height: 25px;" type="text"/> $-10 + 3$	8) $62 - 5^2 \times 2$ <input style="width: 40px; height: 25px;" type="text"/> $(6 + 4) \times 2$
4) $\frac{25}{9} + (10 + 5)$ <input style="width: 40px; height: 25px;" type="text"/> 11	9) $\frac{46}{42} + (4)(8)$ <input style="width: 40px; height: 25px;" type="text"/> $4^2 + 5 \times 2$
5) $\frac{100}{2} \times 8$ <input style="width: 40px; height: 25px;" type="text"/> $8 + 8 \times 2$	10) 33 <input style="width: 40px; height: 25px;" type="text"/> $15 + 7 \times (2 + 6)$

Part 2

Answer the word problems below.

- 1) Parker had \$500 in his bank account. He made 5 withdrawals of \$20 each. What is the balance of his account now? Write an expression that represents the solution to the problem.
- 2) Use the following numbers/operations to write 5 different expressions. Use all 3 numbers in each expression. Consider using brackets and exponents.

2 10 3 \times $-$ \cdot \div

1)	
2)	
3)	
4)	
5)	

Expressions Written As Fractions

When we solve an expression that is written as a fraction, we follow these steps:

- 1) Evaluate the numerator
- 2) Evaluate the denominator
- 3) Divide the denominator by the numerator.

Example

$$\begin{aligned} & \frac{2+8(2)}{15-6} \\ &= \frac{2+(16)}{15-6} \\ &= \frac{18}{9} \\ &= 2 \end{aligned}$$

Questions Solve the expressions using BEDMAS

1) $\frac{12-1(2)}{1(2)}$

2) $\frac{24-6(2)}{2^2}$

3) $\frac{30+8^2}{5^2-11(2)-1}$

4) $\frac{24-8(2)}{2^2}$

5) $\frac{7+8+8}{35-1} \cdot \frac{12(2)+24}{1(2)}$

7) $\frac{3+9+6(5)}{21+3}$

8) $\frac{28+8 \div 2}{3(4)-4}$

9) $\frac{16+8(5)}{(5)(5)-18}$

Expressions as Fractions – The Canteen**Questions**

Write expressions written as a fraction

A canteen sells drinks, chips, and gummies. The prices are displayed in the table below.



Candy	Price
Drinks	\$3
Gummies	\$2
Chips	\$4



1) Sarah, Julie, and James ran the canteen last Monday. They sold 6 bags of chips and 6 drinks.

Write an expression that represents how much money they earned and how much each person will get if they divide the earnings equally.

2) Mark, Dan, Chris, Hugh and Lucas ran the canteen last Tuesday. They sold 9 drinks, 5 gummies, and 2 bags of chips.

Write an expression that represents how much money they earned and how much each person will get if they divide the earnings equally.

3) On a busy day for the canteen, 6 friends ran the canteen. They sold 12 drinks, 10 gummies, and 12 bags of chips.

Write an expression that represents how much money they earned and how much each person will get if they divide the earnings equally.

Adding Square Roots

We can simplify expressions with square roots by evaluating the square root and performing the addition operation afterwards.

Example 1

$$\begin{aligned}\sqrt{9} + \sqrt{25} \\ &= 3 + 5 \\ &= 8\end{aligned}$$

Example 3

$$\begin{aligned}\sqrt{22} + \sqrt{27} \\ &= \sqrt{49} \\ &= 7\end{aligned}$$

Example 3

$$\begin{aligned}\sqrt{40} + \sqrt{81} \\ &= \sqrt{40} + 9 \\ &= \sqrt{49} \\ &= 7\end{aligned}$$

Example 4

$$\begin{aligned}\sqrt{\sqrt{49} + \sqrt{100}} \\ &= \sqrt{7 + 10} \\ &= \sqrt{17} \\ &= 4.12\end{aligned}$$

Directions: Simplify the expressions below

1) $\sqrt{16} + \sqrt{49}$

2) $\sqrt{13}$

3) $\sqrt{81} + \sqrt{64}$

4) $\sqrt{8} + \sqrt{64}$

5) $\sqrt{\sqrt{25} + 20}$

6) $\sqrt{81}$

7) $\sqrt{\sqrt{36} + \sqrt{100}}$

8) $\sqrt{\sqrt{100} + 111}$

9) $\sqrt{\sqrt{49} + 1}$

10) $\sqrt{144} + \sqrt{100}$

11) $\sqrt{\sqrt{4} + \sqrt{49}}$

12) $\sqrt{95} + 26$

Adding and Subtracting Square Roots

We can simplify expressions with square roots by evaluating the square root and performing the addition and subtraction operations afterwards.

Example 1

$$\begin{aligned} \sqrt{36} - \sqrt{25} \\ = 6 - 5 \\ = 1 \end{aligned}$$

Example 3

$$\begin{aligned} \sqrt{75} - 11 \\ = \sqrt{64} \\ = 8 \end{aligned}$$

Example 3

$$\begin{aligned} \sqrt{23} - \sqrt{49} \\ = \sqrt{23} - 7 \\ = \sqrt{16} \\ = 4 \end{aligned}$$

Example 4

$$\begin{aligned} \sqrt{\sqrt{144} - \sqrt{64}} \\ = \sqrt{12 - 8} \\ = \sqrt{4} \\ = 2 \end{aligned}$$

Ques _____ expressions below

1) $\sqrt{25} - \sqrt{9}$

2) $\sqrt{18}$

3) $\sqrt{64} + \sqrt{36}$

4) $\sqrt{89} - \sqrt{64}$

5) $\sqrt{15} - \sqrt{36}$

6) $\sqrt{4} + \sqrt{81}$

7) $\sqrt{\sqrt{100} - \sqrt{36}}$

8) $\sqrt{\sqrt{100} + 111}$

9) $\sqrt{\sqrt{144} - 19}$

10) $\sqrt{121} + \sqrt{81}$

11) $\sqrt{\sqrt{81} - \sqrt{25}}$

12) $\sqrt{168} - 24$

Task Cards: Square Root Operations

Objective

What are we learning about?

Students will practice adding, subtracting, multiplying, and dividing square roots using simplified expressions to enhance their understanding of operations with square roots.

Materials

What you will need for the activity

- Task cards
- Separate sheet of paper for answers
- Pencils

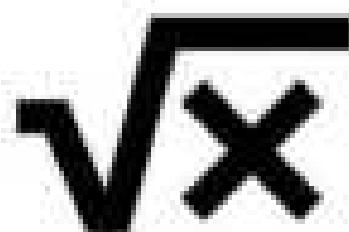

Instructions

How to run the activity

1. Begin by reviewing the concepts of adding, subtracting, multiplying, and dividing square roots, and the importance of simplifying expressions.
2. Organize the students into pairs and provide each pair with their sets of task cards containing square root operations.
3. Give each pair an answer recording sheet to record their responses.
4. Encourage teamwork by having students collaborate with each other to solve the square root operations on each task card.
5. Allow students to select any task card to begin with, emphasizing that they can complete the cards in any order they prefer.
6. Instruct students to solve the operation on their chosen card and write the simplified answer on their answer sheet.
7. If using a timer, set it for 30 minutes to encourage focus and manage classroom time effectively.
8. After the activity, review the answers collectively, discussing any challenging operations and the strategies used to solve them.
9. Have students reflect on the activity, sharing the methods they applied and obstacles they overcame.

Task Cards

Cut out the task cards below

Task Card 21:

Calculate:

$$\sqrt{\sqrt{16} \times \sqrt{4}} = \underline{\hspace{2cm}}$$

Task Card 26:

Calculate:

$$\sqrt{81} + \sqrt{16} = \underline{\hspace{2cm}}$$

Task Card 22:

Calculate:

$$\sqrt{3} \times \sqrt{6} = \underline{\hspace{2cm}}$$

Task Card 27:

Calculate:

$$\sqrt{\sqrt{49} + \sqrt{81}} = \underline{\hspace{2cm}}$$

Task Card 23:

Calculate:

$$\sqrt{\sqrt{100} + \sqrt{36}} = \underline{\hspace{2cm}}$$

Task Card 28:

Calculate:

$$\sqrt{\sqrt{4} + \sqrt{9}} = \underline{\hspace{2cm}}$$

Task Card 24:

Calculate:

$$\sqrt{\sqrt{144} + \sqrt{49}} = \underline{\hspace{2cm}}$$

Task Card 29:

Calculate:

$$\sqrt{\sqrt{144} \div \sqrt{9}} = \underline{\hspace{2cm}}$$

Task Card 25:

Calculate:

$$\sqrt{\sqrt{81} - 3} = \underline{\hspace{2cm}}$$

Task Card 30:

Calculate:

$$\sqrt{\sqrt{169} \div 13} = \underline{\hspace{2cm}}$$

PREVIEW

Task Cards: Square Root Operations**Answers**

Record your answers below

1	
2	
3	
4	
5	
6	
7	
8	
9	
10	
11	
12	
13	
14	
15	

16	
17	
18	
19	
20	
24	
25	
26	
27	
28	
29	
30	

PREVIEW

Order of Operations – Square Roots

When we have a square root in an expression, solve it first. Afterwards, follow the BEDMAS rules.

Example 1

$$\begin{aligned} & \sqrt{144} - 3^2 + 8 \\ & = 12 - 3^2 + 8 \\ & = 12 - 9 + 8 \\ & = 11 \end{aligned}$$

Example 2

$$\begin{aligned} & 7^2 - 10 \times \sqrt{9} \\ & = 7^2 - 10 \times 3 \\ & = 49 - 10 \times 3 \\ & = 49 - 30 \\ & = 19 \end{aligned}$$

Example 3

$$\begin{aligned} & 6^2 + \sqrt{36} - 2 \\ & = 6^2 + 6 - 2 \\ & = 36 + 6 - 2 \\ & = 40 - 2 \\ & = 38 \end{aligned}$$

Instruction Solve the following expressions using BEDMAS

1) $\sqrt{100} - 5^2 + 15$

3) $8^2 + \sqrt{64} - 3$

4) $\sqrt{121} - 2^3 + 22$

5) $6^2 + \sqrt{144} - 2$

6) $8^2 - 1$





7) $10^2 + \sqrt{25} - 12$

8) $(\sqrt{121} - 8) \times 2^3$

9) $8^2 + \sqrt{4} \times 3$

Adding Integers – Zero Pairs



  	
$8 + (-6) = 2$	

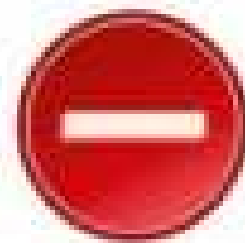

Question

Cross out the zero pairs. What is left?

1)

 $\underline{\quad} + \underline{\quad} = \underline{\quad}$

2)

 $\underline{\quad} + \underline{\quad} = \underline{\quad}$

3)

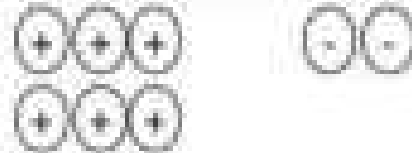
 $\underline{\quad} + \underline{\quad} = \underline{\quad}$

4)

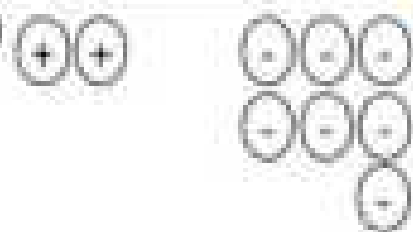
 $\underline{\quad} + \underline{\quad} = \underline{\quad}$

5)

 $\underline{\quad} + \underline{\quad} = \underline{\quad}$

6)

 $\underline{\quad} + \underline{\quad} = \underline{\quad}$

7)

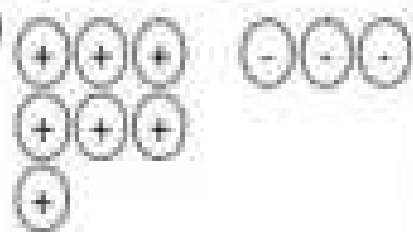
 $\underline{\quad} + \underline{\quad} = \underline{\quad}$

8)

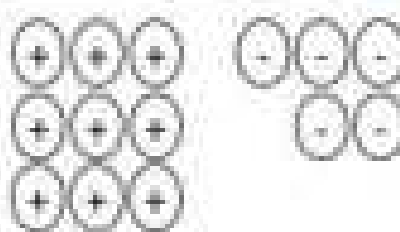
 $\underline{\quad} + \underline{\quad} = \underline{\quad}$

9)

 $\underline{\quad} + \underline{\quad} = \underline{\quad}$

10)

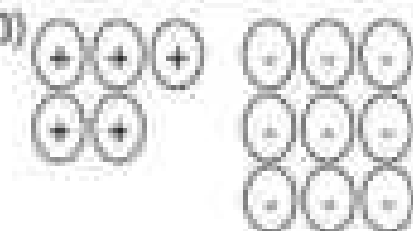
 $\underline{\quad} + \underline{\quad} = \underline{\quad}$

11)

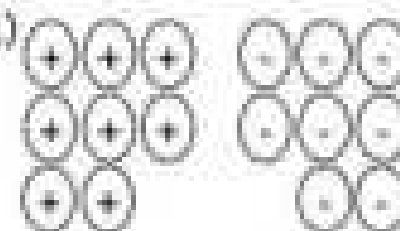
 $\underline{\quad} + \underline{\quad} = \underline{\quad}$

12)

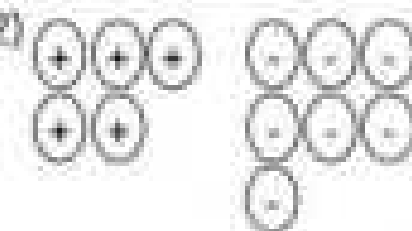
 $\underline{\quad} + \underline{\quad} = \underline{\quad}$

Golf - Adding Integers – Zero Pairs

Word Problems

Solve the word problems below using counter chips.



1) Bailey played 3 rounds of golf. She filled out her scorecard, but she forgot what she shot in round 2. Fill it in for her.

Round	Score
1	-6
2	
3	+9
Total Score	+10



Equation: _____ + _____ + _____ = _____

2) Ryker played 3 rounds of golf. His final scores for all three rounds are on the scorecard. What is his total score?

Round	Score
1	-13
2	-8
3	+11
Total Score	



Equation: _____ + _____ + _____ = _____

3) Sara played 4 rounds of golf. Her final scores are written on the scorecard, but she can't remember what she scored on her first round. Help her complete her score card.

R1	R2	R3	R4	Total Score
	3	-6	-5	-17



Equation: _____ + _____ + _____ + _____ = _____

4) Jason played 4 rounds of golf. His final scores are written on the scorecard. What is his total score?

R1	R2	R3	R4	Total Score
-11	-6	8	-7	



Equation: _____ + _____ + _____ + _____ = _____

Adding Integers – Using Number Lines

**Part 1**

Solve the questions below

1) $9 + (-5)$ <input style="width: 50px; height: 20px;" type="text"/>	6) $-35 + 21 + (-17)$ <input style="width: 50px; height: 20px;" type="text"/>
2) $15 + (-7) + 5$ <input style="width: 50px; height: 20px;" type="text"/>	7) $17 + (-25) + (-11)$ <input style="width: 50px; height: 20px;" type="text"/>
3) $-17 + 30 + (-15)$ <input style="width: 50px; height: 20px;" type="text"/>	8) $-10 + (-10) + 35 + (-12)$ <input style="width: 50px; height: 20px;" type="text"/>
4) $20 + (-32) + (-7)$ <input style="width: 50px; height: 20px;" type="text"/>	9) $19 + (-3) + (-7) + (22)$ <input style="width: 50px; height: 20px;" type="text"/>
5) $-18 + 20 + (-21)$ <input style="width: 50px; height: 20px;" type="text"/>	10) $12 + (-13) + 13$ <input style="width: 50px; height: 20px;" type="text"/>

Part 2

Answer the word problems below. Write the equations.

- 1) You start at point A and take 19 steps forward to point B, then 29 steps backward to point C, followed by 10 steps backward to point D, and finally 31 steps forward to point E. How many steps are you away from the starting point, point A?



- 2) A submarine starts at sea level and dives 52m down before coming up 16m. It makes another plunge down 39m and then rises 14m. How many meters is it below sea level?



Adding Integers – Using Number Lines

Adding Integers Rules

$\oplus + \oplus = \oplus$ Adding 2 positive integers will always give a positive answer

$\ominus + \ominus = \ominus$ Adding 2 negative integers will always give a negative answer

$\oplus + \ominus = \ominus$ Adding integers with different signs \rightarrow use the larger number

$\ominus + \oplus = \oplus$ Adding integers with different signs \rightarrow use the larger number

*** If the integers have the same sign, add them and keep the sign

*** If the integers have different signs, subtract them and use the sign of the larger number

Part 1 Use the rules above to solve the 1-step questions below

1) $68 + (-32)$	5) $(-121) + 11$
2) $57 + (-76)$	6) $(-12) + (-11)$
3) $-115 + (-122)$	7) $(-7) + (-7)$
4) $(+133) + (+77)$	8) $-355 + (-12)$

Part 2 Simplify the multi-step questions and use the rules above

1) $31 + (-26) + (-23)$	4) $52 + 35 + (-53) + (-37)$
2) $54 + (-58) + 33$	5) $78 + (-75) + (-33) + 45$
3) $-82 + (-42) + (-35)$	6) $-128 + 96 + (-90) + 132$

Adding Integers - Word Problems**Solve**

Answer the questions below. Include the equation and negative integers involved

1) While playing a video game, Alex scored 20 points in the first round and lost 12 points in the second round. What is his net score after the two rounds?

2) On Monday, the temperature was -3°C . On Tuesday, it increased by 7°C . What was the temperature on Tuesday?



3) In a game, Sarah scored -15 points, and Tom scored 10 points. What is the combined score of Sarah and Tom?

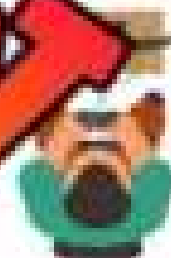

4) A submarine is at a depth of 180 meters below sea level. It descends another 60 meters. What is its new depth below sea level?

Subtracting Integers – Keep, Flip, Change

Subtraction Integers Rules

To subtract integers, it is easiest to change the operation to addition and then follow the addition rules. We can do this by using the rule – Keep, Flip, Change. We keep the first number the same, flip the operation from subtraction to addition, and then change the third number's sign.

Example: $5 - (-6) = ?$ becomes $5 + 6 = 11$

Keep the
first
integer

Flip the
operation

Change the
sign of the next
integer

Part 1

Use the rule above to solve the problems.

1) $11 - (-6) =$

7) $(+45) - (+43) =$

2) $24 - (-11) =$

8) $(+7) - (-3) =$

3) $(-11) - 8 =$

9) $(-1) - (-1) =$

4) $(-23) - 13 =$

9) $(-116) - (-116) =$

5) $(-31) - (-12) =$

10) $159 - (-77) =$

Part 2

Answer the word problem below. Write the equation.

Jake has +\$130 in his bank account. Todd owes \$80 to his brother and has no other money. How much more money does Jake have than Todd?

Subtracting Integers – Number Line

Follow these steps to use a number line for solving subtraction questions involving integers.

- 1) Determine how far the numbers are on a number line (25 and -35 has a distance of 60 in total – magnitude of 60)
- 2) The direction you move from the second number to the first number will tell you which sign to use. When we move left, we are moving in a negative direction (-) and when we move right, we are moving in a positive direction (+)

Ex. $25 - (-35) =$



Questions

Use number lines to solve the questions

1) $(-30) - (-16) =$



2) $25 - (-25) =$



3) $(-20) - 10 =$



4) $(-35) - 19 =$



5) $31 - (-37) =$



6) $(-38) - (-22) =$



7) $40 - (-36) =$



Subtracting Integers – Number Line



Part 1

Solve the questions below

1) $27 - () =$

6) $(-35) - 22 =$

2) $() - (-5) =$

7) $27 - (-16) =$

3) $(-23) - 31 =$

8) $(-38) - (-15) =$

4) $36 - (-17) =$

$(+13) =$

5) $(-39) - 18 =$

9) $() - (-2) =$

Part 2

Answer the word problem below. Write the equation in the box.

- 1) The winner of a golf tournament scored a -21 after four rounds. The 2nd place golfer scored a $+47$. What is the difference between these two scores?



- 2) Dan and Brianna both invested some of their money in the stock market. Dan lost $-\$386$ and Brianna earned $+\$521$. What is the difference between their earnings and losses?



Subtracting Integers – Word Problems

Questions

Answer the questions below.

1) The temperature in the morning was 5°C and dropped to -3°C in the evening. What was the change in temperature?

2) A company made a profit of $\$3,000$ in January. In February, they lost $\$8,600$ in profits. What is the difference between the two months?

3) A mountain peak is $6,387$ meters above sea level. A valley is 115 meters below sea level. What is the difference in elevation between the mountain peak and the valley?

4) A submarine was at a depth of -150 meters below sea level. It then descended until it was -325 metres below sea level. What was its change in metres below sea level?



Multiplying Integers – Number Line

Follow these steps to use a number line for solving multiplication questions involving integers.

- 1) The dog always starts at 0
- 2) The multiplier tells us how many steps the dog will take.
- 3) The multiplicand tells us to walk forwards or backwards. For a positive number, walk forwards. For a negative number, walk backwards.
- 4) The multiplicand also tells us how many jumps to take.
- 5) If both numbers are negative, the answer will be positive (the dog will jump in the opposite direction).

Multiplier

$$-5 \times -4 = 20$$

Multiplicand

Product

Ex: $(-5) \times (-4) = 20$ 

Take 5 steps, with 4 jumps
walking forwards to 20
(multiplier x multiplicand = product)

Questions

Use a number line to solve the questions

1) $(-5) \times (-7) =$



2) $8 \times (-4) =$



3) $(-7) \times 3 =$



4) $(-9) \times (-4) =$



5) $5 \times (-8) =$



6) $(-20) \times (-2) =$



Multiplying Integers

Multiplying Integers Rules

- $(+) \times (+) = (+)$ Multiplying 2 positive integers will give a positive answer
 $(-) \times (-) = (+)$ Multiplying 2 negative integers will give a positive answer
 $(+) \times (-) = (-)$ Multiplying integers with different signs will give a negative answer
 $(-) \times (+) = (-)$ Multiplying integers with different signs will give a negative answer

Part 1 Use the rules to answer the 1-step equations below

1) $5 \times (-2) =$ <input type="text"/>	4) $(-6) \times (-3) =$ <input type="text"/>	11) $(-8) \times (-12) =$ <input type="text"/>
2) $(-7) \times 7 =$ <input type="text"/>	5) $(-9) \times (-4) =$ <input type="text"/>	12) $13 \times (-9) =$ <input type="text"/>
3) $(-8) \times (-3) =$ <input type="text"/>	6) $(-12) \times (-5) =$ <input type="text"/>	13) $(-16) \times 8 =$ <input type="text"/>
4) $12 \times 8 =$ <input type="text"/>	9) $(-13) \times (-11) =$ <input type="text"/>	14) $(-2) \times (-13) =$ <input type="text"/>
5) $(-11) \times 12 =$ <input type="text"/>	10) $20 \times 7 =$ <input type="text"/>	15) $(-3) \times (-25) =$ <input type="text"/>

Part 2 Simplify the multi-step expressions and use the rules to answer

Ex) $2 \times (-3) \times (-8)$ $= (-6) \times (-8)$ $= 48$ <input type="text"/>	3) $5 \times 10 \times (-10) \times (-10)$ <input type="text"/>
1) $(7) \times (-3) \times 2$ <input type="text"/>	4) $6 \times (-2) \times (-4) \times 2$ <input type="text"/>
2) $(-4) \times (-6) \times (-3)$ <input type="text"/>	5) $(-9) \times 3 \times (-2) \times 10$ <input type="text"/>

Multiplication Squares

Part 1

Fill in the squares by multiplying the integers.

1)

x	5	-8
-3		
-7		

2)

x	2	-9
-8		
-6		

3)

x	7	-1
-9		
-3		

4)

x	-3	-7	-10
-8			
6			

6)

x	12	-6
-4		
9		

7)

x	-15	-13
-3		
-5		

8)

x	-6	23	-56
-4			
7			

Part 2

Fill in the squares by multiplying the integers.

1)

x	6	-5	2
-4			
-7			
3			

2)

x	10	-11	12
-3			
-7			
-9			

3)

x	-5	15	-25
-2			
-4			
6			

Integer Multiplication Chart

Directions Fill in the chart by multiplying the integers

x	5	4	3	2	1	0	-1	-2	-3	-4	-5
5											
4											
3											
2											
1											
0											
-1											
-2											
-3											
-4											
-5											

PREVIEW

Multiplying Integers – Word Problems**Solve**

Answer the questions below. Include the equation and negative integers involved.

1) An airplane is descending at a rate of 450 m per minute. After 20 minutes, what is the position of the airplane relative to its position before the 20 minutes?

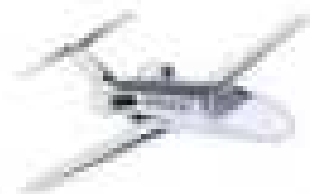

2) A business earns \$20 per month for an entire year. How much did the business make?

3) An elevator goes down 3 floors every 2 minutes. How many floors does it descend in 10 minutes?



4) A student correctly answered 5 questions on a quiz, gaining 3 points each, but lost 2 points for each of the 4 incorrect answers. What was the student's total score?

Exit Cards

Cut Out

Cut out the exit cards below and have students complete them at the end of class.

Name _____

1) Solve the questions below.

a) $15 \div (-3) =$ _____

b) $(-7) \times 5 = (-3) \times 2 =$ _____

c) A store has a monthly loss of \$280 for 8 months. How much did the store lose over those 8 months?

Name _____

1) Solve the questions below.

a) $15 \div (-3) =$ _____

b) $(-7) \times 5 = (-3) \times 2 =$ _____

c) A store has a monthly loss of \$280 for 8 months. How much did the store lose over those 8 months?

Name _____

1) Solve the questions below.

a) $15 \div (-3) =$ _____

b) $(-7) \times 5 = (-3) \times 2 =$ _____

c) A store has a monthly loss of \$280 for 8 months. How much did the store lose over those 8 months?

Name _____

1) Solve the questions below.

a) $15 \div (-3) =$ _____

b) $(-7) \times 5 = (-3) \times 2 =$ _____

c) A store has a monthly loss of \$280 for 8 months. How much did the store lose over those 8 months?

PREVIEW

Dividing Integers – Number Line

Follow these steps to use a number line for solving division questions involving integers.

- 1) The dog always starts at 0
- 2) The dog jumps by the divisor until it reaches the dividend.
- 3) Your answer is how many jumps it takes
- 4) The answer is negative if the dog faces the negative side and positive if it faces the positive side.

Dividend

$$\rightarrow (-15) \div 5 = -3$$

Divisor

Quotient

Ex. $(-15) \div 5 =$ 

Questions

Use the number lines to solve the questions

1) $(-25) \div (-5) =$



2) $12 \div (-4) =$



3) $(-32) \div 4 =$



4) $(-18) \div (-6) =$



5) $24 \div (-8) =$



6) $(-36) \div (-3) =$



Dividing Integers

Dividing Integers Rules - Same as Multiplication!

- $\oplus \div \oplus = \oplus$ Dividing 2 positive integers will give a positive answer
 $\ominus \div \ominus = \oplus$ Dividing 2 negative integers will give a positive answer
 $\oplus \div \ominus = \ominus$ Dividing integers with different signs will give a negative answer
 $\ominus \div \oplus = \ominus$ Dividing integers with different signs will give a negative answer

Part 1 Use the rules to answer the 1-step equations below

1) $15 \div (-3) =$ <input type="text"/>	8) $(-60) \div (-12) =$ <input type="text"/>
2) $(-49) \div 7 =$ <input type="text"/>	9) $(-8) =$ <input type="text"/>
3) $(-66) \div (-6) =$ <input type="text"/>	10) $(-9) =$ <input type="text"/>
4) $32 \div 4 =$ <input type="text"/>	11) $(-12) \div (-3) =$ <input type="text"/>
5) $(-81) \div 9 =$ <input type="text"/>	12) $32 \div (-4) =$ <input type="text"/>

Part 2 Simplify the multi-step expressions and use the rules

Ex) $28 \div (-7) \div (-2)$ $= (-4) \div (-2)$ $= 2$ <input style="float: right; margin-top: 10px;" type="text"/>	3) $50 \div 5 \div (-2)$ <input style="float: right; margin-top: 10px;" type="text"/>
1) $(36) \div (-3) \div 6$ <input style="float: right; margin-top: 10px;" type="text"/>	4) $48 \div (-4) \div (-3) \div 2$ <input style="float: right; margin-top: 10px;" type="text"/>
2) $(-72) \div (-8) \div (-3)$ <input style="float: right; margin-top: 10px;" type="text"/>	5) $(-112) \div 2 \div (-2) \div 4$ <input style="float: right; margin-top: 10px;" type="text"/>

Division Squares

Part 1

Fill in the squares by dividing the integers.

1)

+	5	-3
-15		
-30		

2)

+	-6	3
18		
-12		

3)

+	7	-2
28		
-56		

4)

+	12	
-48		
36		

5)

+	-4	-8
56		
-32		

6)

+	-2	-12
-60		
96		

7)

+	5	15
-75		
-105		

8)

+	-22	
-88		
66		

9)

+	3	-9

Part 2

Fill in the squares by dividing the integers.

1)

+	2	-6	-10
-60			
90			
-180			

2)

+	-3	-6	9
18			
-54			
90			

3)

+	-5	15	-25
-75			
-150			
225			

Math Jeopardy – Integer Operations

Objective

What are we learning about?

Students will practice adding, subtracting, multiplying, and dividing numbers, while solving word problems using all four operations in a fun and engaging way.

Materials

You will need for the activity.

- Jeopardy board template
- Buzzer or bell

**Instructions**

How you will complete this activity.

1. Print the Jeopardy board on the next page.
2. Divide the class into two teams.
3. Ask one team to go first by selecting a point value.
4. Read the question aloud from the point value.
5. The first team to ring the bell or buzzer gets to answer.
6. If they answer correctly, award them the points. If not, another team can answer.
7. Continue the game until all questions have been answered.
8. Tally the points to determine the winning team.
9. Conclude by discussing what they learned about the topic in the questions.

Jeopardy Questions

Ask students the questions below.

\$100	\$200	\$300	\$400	\$500
$12 + (-5) + 3$	$20 + (-7) + 9$	$(-15) + 25 + (-10)$	$(-45) + 30 + (-20)$	$78 + (-40) + 62$
$-24 + (-8)$	$(-15) + 9$	$43 + (-17) + 12$	$(-75) + (-20) + 33$	$108 + 45 + (-180)$
$4 + (-3)$	$(-5) + (-8)$	$(-9) + 12 + (-2)$	$25 + (-6) + 4$	$(-11) + (-12) + (-5)$
$20 + (-1)$	$(-72) + 9$	$180 + (-6) + 3$	$(-1440) + (-12) + 6$	$(-360) + 8 + (-3)$
You start with 75 points, then get 8 points. How many points do you have now?	A submarine descends 75 meters. How far does it descend in total?	A submarine is 120 meters below sea level. It rises 50 meters and then descends 50 meters. How far below sea level is it now?	A snowstorm causes the temperature to drop by -3°C every hour. After 10 hours, what's the total temperature change?	A glacier retreats by -2.5 meters every month. How far will it retreat in 2 years?
A diver is 12 meters below sea level. She descends another 8 meters. How far below sea level is she now?	The stock market drops 12 points one day, 6 the next day, and then another 8 points the next day. How much did the stock market drop in total?	A debt of $-\$1$ is to be divided equally among 5 people. How much debt does each person take on?	A company's value decreases by $-\$100$ per week. How much will the company's value decrease after 10 weeks?	A scuba diver descends -4 meters per minute. How far will she descend after 2 minutes?
The temperature was -5°C in the morning. By noon, it rose by 7°C . What's the temperature now?	You start with -40 points in a quiz competition. You earn 55 points in the first round and lose 10 points in the second round. What's your final score?	A mountain climber descends -200 meters per hour. How far has the climber descended after 7 hours?	A company's value decreases by $-\$350$ per day. How much will the company's value decrease in 20 days?	A company experiences a daily loss of $-\$5,000$ for 14 days. What's the total loss over the 14 days?

Integers Quiz

Part 1 Solve the questions below

1) $9 + (-5) =$

2) $11 + (-9) =$

3) $(-15) + 6 =$

4) $(-13) + 8 =$

5) $(-31) + 19 =$

6) $(-43) + 15 =$

Part 2 Solve the questions below

1) $11 + (-4) + 4 =$

2) $8 + (-17) =$

3) $25 + (-18) + 13 =$

4) $(-1) + (-1) =$

Part 3 Answer the word problems below. Write the answer in the box.

- 1) You start at point A and take 17 steps forward to point B. Then, you take 15 steps backward to point C, followed by 25 steps backward to point D. Finally, you take 19 steps forward to point E. How many steps are you away from the starting point, point A?



- 2) A submarine starts at sea level and dives 17m down before coming up 11m. It makes another plunge down 43m and then rises 27m. How many meters is it below sea level?



Part 4

Solve the subtraction equations below

1) $15 - (-6) =$

2) $(+18) - (+13) =$

3) $27 - (-13) =$

4) $(+45) - (-31) =$

5) $(-51) - 18 =$

6) $(-84) - (-55) =$

Part 5

Answer the word problems below. Write the equation for each question.

1) The winner of a tournament scored a -38 after four rounds. The last place golfer scored a $+12$. What is the difference between these two scores?

2) The average temperature at the South Pole is -49 degrees Celsius. The average temperature in the North Pole is -20 degrees Celsius. What is the difference in temperatures between the two Poles?



Part 6

Solve the multiplication equations below

1) $6 \times (-3) =$

2) $(-13) \times (-5) =$

3) $(-7) \times (-12) =$

4) $(-7) \times 9 =$

5) $8 \times (-6) =$

6) $4 \times (-9) =$

7) $(8) \times (-5) \times 2$

8) $7 \times (-4) \times (-2) \times 1$

Part 7 Fill in the tables below

1)

x	5	-4
-20		
-40		

2)

x	-6	3
30		
-12		

3)

x	7	-2
42		
-56		

Part 8 Complete the input/output tables by following the rules

1)

Input	Output
-1	
-8	
4	
7	
11	
Multiply by -3	

2)

Input	Output
-52	
18	
2	
3	
Divide by	

3)

Input	Output
-11	
-7	
-4	
2	
12	
Multiply by -8	

Part 9 Calculate the answers to the equations

1) $9 + (-5) \times (-3)$

2) $7 \times (-5 + -8)$

4) $(-5 \times 9) \div (5 \times 1)$

5) $(\frac{-24}{6}) - (-3 \times 1)$

6) $(-48 \div 6)(4)$

Part 10

Write an expression that represents the situation and solve.

1) An elevator starts at the ground floor. It travels up 12 floors before going down 8 floors. Next, it travels twice as high as it is now. What floor is the elevator on now?

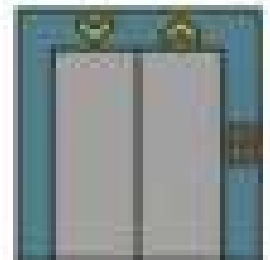

2) Nate golfed last year. He scored a -2 for 3 of the rounds. For each of his other 3 rounds, he scored a $+3$. What was his score for all 6 rounds?



3) Neil rushed for -8 yards in the first quarter of his football game. He rushed for $+22$ yards in the second quarter. In the last two quarters, he rushed for $+13$ yards in each quarter. How many total yards did he rush for?



Adding Fractions With Common Denominators

Questions

Add the fractions below using the models.

1) $\frac{4}{5} + \frac{2}{5} = \frac{6}{5}$ or $1\frac{1}{5}$

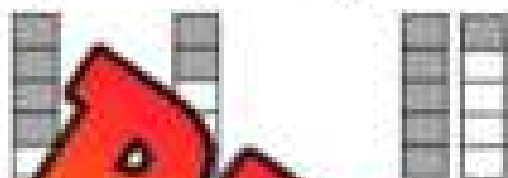

2) $\frac{3}{7} + \frac{2}{7} = \underline{\hspace{2cm}}$

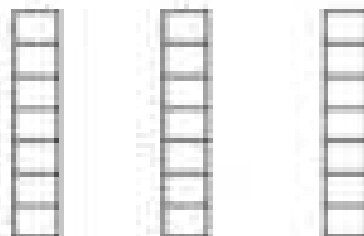

3) $\frac{5}{8} + \frac{3}{8} = \underline{\hspace{2cm}}$

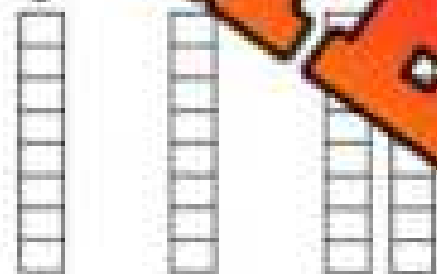

4) $\frac{3}{4} + \frac{2}{4} = \underline{\hspace{2cm}}$

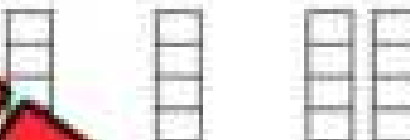

5) $\frac{2}{3} + \frac{3}{3} = \underline{\hspace{2cm}}$



6) $\frac{6}{6} + \frac{2}{6} = \underline{\hspace{2cm}}$



7) $\frac{4}{8} + \frac{5}{8} = \underline{\hspace{2cm}}$

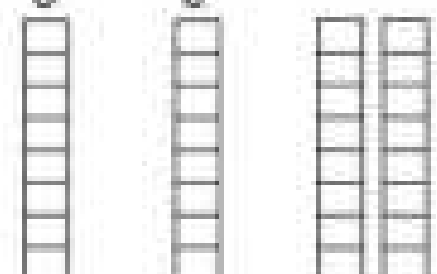

8) $\frac{7}{9} + \frac{1}{9} = \underline{\hspace{2cm}}$

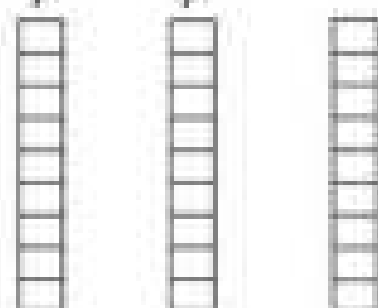

Adding Fractions With Common Denominators

Questions

Solve the word problems

1) At the end of the birthday party, there were 4 pizza boxes left. The first box had $\frac{5}{8}$ slices left. The second box had $\frac{3}{8}$ slices left. The third box had $\frac{4}{8}$ slices remaining and the last box had $\frac{6}{8}$ left.

- a) How much pizza is left in total?
- b) How many pizzas are left?
- c) How many slices are left if there were 8 slices in each box?



2) Thomas is starting a 5-day running program. The distances he ran are presented in the table.

Day	Distance (km)
Monday	$\frac{3}{8}$
Tuesday	$\frac{6}{8}$
Wednesday	$1\frac{1}{8}$
Thursday	$2\frac{4}{8}$
Friday	$2\frac{1}{8}$

- a) How far did he run after the 5 days?
- b) Which day did he run the most?



3) Shelly bought $\frac{88}{100}$ metres of red fabric, $3\frac{7}{10}$ metres of blue fabric, and $1\frac{2}{10}$ metres of green fabric.

- a) How much fabric did she buy in total?
- b) Which colour of fabric did she buy the most of?

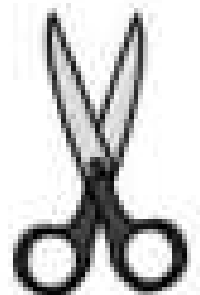

Adding Mixed Fractions

When adding a mixed fraction, we have two options we can use to solve.

- 1) We can keep the wholes and add them together first and then add the fractional parts after.
- 2) We can convert the mixed fractions to improper fractions and then add them

Part 1

Add the mixed fractions together using option 1

Ex) $10\frac{1}{2} + 10\frac{1}{2} =$	1) $6\frac{2}{5} + 3\frac{1}{5} =$	2) $5\frac{3}{9} + 11\frac{2}{9} =$
3) $8\frac{4}{8} + 5\frac{3}{8} =$		5) $2\frac{4}{8} + 6\frac{3}{8} =$
6) $12\frac{5}{9} + 10\frac{8}{9} =$	7) $8\frac{9}{12} + 4\frac{5}{12} =$	4) $15\frac{8}{10} + 3\frac{4}{10} =$

Part 2

Add the mixed fractions together using option 2

Ex) $3\frac{2}{8} + 7\frac{4}{8} = \frac{26}{8} + \frac{60}{8} = \frac{86}{8}$ or $10\frac{6}{8}$	1) $3\frac{4}{8} + 4\frac{2}{8} =$
2) $6\frac{1}{4} + 8\frac{2}{4} =$	3) $11\frac{7}{9} + 7\frac{3}{9} =$
4) $10\frac{8}{11} + 9\frac{5}{11} =$	5) $12\frac{6}{14} + 6\frac{10}{14} =$

Adding Mixed Fractions**Questions**

Solve the word problems

1) Arabella made a birthday cake for her mom. She used $2\frac{1}{4}$ cups of white sugar, $1\frac{1}{4}$ cups of brown sugar, and $3\frac{1}{2}$ cups of icing sugar. How many cups of sugar did she use?

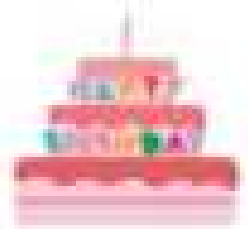

2) The Miller family went on vacation. The drive to the airport took them $3\frac{1}{2}$ hours. The flight took $5\frac{1}{4}$ hours and the drive from the airport to the hotel took $2\frac{3}{8}$ hours. How many hours did it take them to get to the hotel?



3) The grade 8 classes collected garbage on Earth Day. Class one collected $3\frac{1}{8}$ kg of garbage. Class two collected $2\frac{1}{3}$ kg and class three collected $4\frac{1}{2}$ kg. How much garbage did the grade 8 classes collect in total?



Subtraction Fractions - Common Denominators**Questions**

Subtract the fractions below using the models

1) $\frac{4}{6} - \frac{2}{6} = \frac{2}{6}$

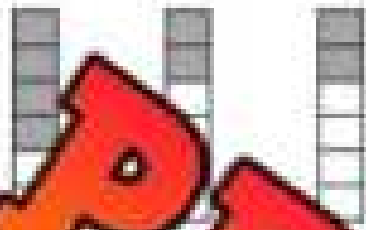

2) $\frac{6}{7} - \frac{3}{7} = \underline{\quad}$

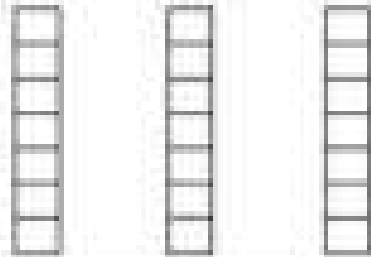

3) $\frac{7}{8} - \frac{1}{8} = \underline{\quad}$

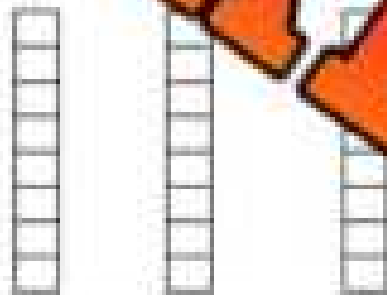

4) $\frac{3}{5} - \frac{1}{5} = \underline{\quad}$

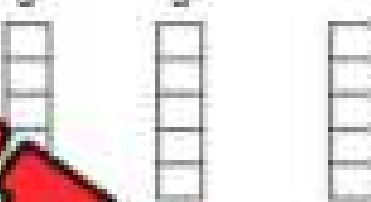

5) $\frac{6}{7} - \frac{3}{7} = \underline{\quad}$

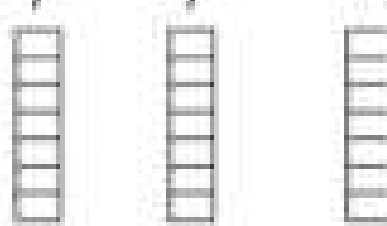

6) $\frac{3}{5} - \frac{1}{5} = \underline{\quad}$

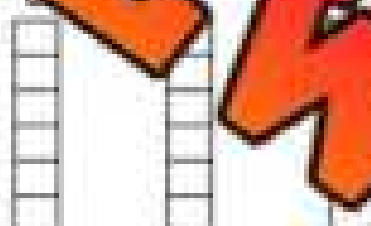

7) $\frac{7}{9} - \frac{4}{9} = \underline{\quad}$

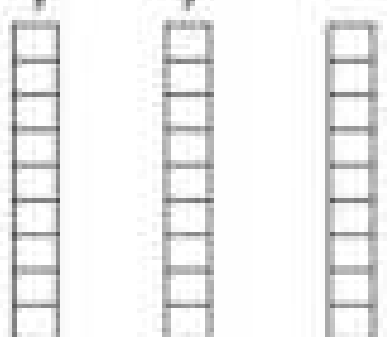

8) $\frac{10}{12} - \frac{7}{12} = \underline{\quad}$

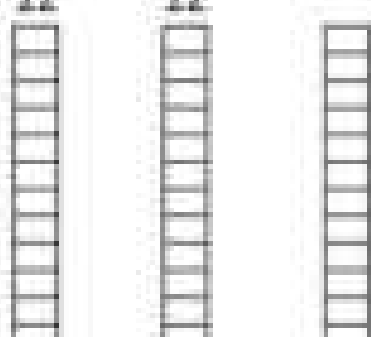
**PREVIEW**

Subtraction Fractions – Word Problems**Questions**

Solve the word problems

1) Drew ran $4\frac{3}{4}$ km yesterday in 20 minutes. Lindsay ran $\frac{10}{4}$ km yesterday in 20 minutes.

- a) Who ran further in the 20 minutes?
b) How much further did they run?



2) Baker found a black snake in his backyard. The green snake was $22\frac{3}{4}$ cm long. The black snake was $\frac{45}{4}$ cm long.

- a) Which snake is longer?
b) How much longer is the snake?



3) Ayden picked $3\frac{5}{8}$ baskets of strawberries and Ayden picked $\frac{1}{8}$ baskets of strawberries.

- a) Who picked more strawberries?
b) How much more did they pick?



4) Sharon has practiced playing the piano for $2\frac{2}{7}$ hours this week. She wants to practice for $\frac{15}{7}$ hours.

- a) How much more time does she need to practice?
b) If she wants to practice for 10 hours, how much longer does she need to practice?



Subtracting Fractions With unlike Denominators**Part 1**

Use the common denominators to subtract the fractions below

1) $\frac{6}{7} - \frac{4}{14} = \frac{12}{14} - \frac{4}{14} = \frac{8}{14}$

2) $\frac{3}{8} - \frac{2}{24} = \frac{9}{24} - \frac{2}{24} = \frac{7}{24}$

3) $\frac{3}{4} - \frac{1}{12} = \frac{9}{12} - \frac{1}{12} = \frac{8}{12}$

4) $\frac{5}{6} - \frac{1}{3} = \frac{5}{6} - \frac{2}{6} = \frac{3}{6}$

5) $\frac{9}{12} - \frac{2}{4} = \frac{9}{12} - \frac{6}{12} = \frac{3}{12}$

6) $\frac{4}{5} - \frac{4}{15} = \frac{8}{15} - \frac{4}{15} = \frac{4}{15}$

7) $\frac{2}{3} - \frac{3}{9} = \frac{4}{9} - \frac{3}{9} = \frac{1}{9}$

8) $\frac{1}{2} - \frac{1}{30} = \frac{15}{30} - \frac{1}{30} = \frac{14}{30}$

Part 2

Create common denominators and then subtract the fractions below

1) $\frac{10}{15} - \frac{2}{5} =$

2) $\frac{10}{14} - \frac{3}{7} =$

3) $\frac{10}{18} - \frac{5}{9} =$

4) $\frac{5}{6} - \frac{6}{12} =$

5) $\frac{12}{20} - \frac{8}{40} =$

6) $\frac{11}{16} - \frac{3}{8} =$

Subtracting Fractions – Word Problems**Questions**

Solve the word problems.

1) Brianna baked a cake. She used $\frac{4}{6}$ of a cup of white sugar and $\frac{2}{6}$ of a cup of brown sugar. How much more white sugar was used than brown sugar?



2) Mike has to walk $\frac{3}{4}$ kilometre to school. He has walked $\frac{1}{2}$ a kilometre already. How much further does he have to walk?



3) Clara has put $\frac{2}{3}$ of a cup of chocolate chips in a cookie. She needs to put in $\frac{3}{4}$ of a cup. How much more does she need to put in?



4) Lawrence ran 5km in $\frac{3}{8}$ of an hour. Skyler ran 5km in $\frac{4}{10}$ of an hour.

- a) Who ran the 5km faster?
- b) How much faster did they run it in?



Subtracting Mixed Fractions

When subtracting a mixed fraction, we have two options we can use to solve.

- 1) We can keep the wholes and subtract them first and then subtract the fractional parts after.
- 2) We can convert the mixed fractions to improper fractions and then subtract.

Part 1

Subtract the mixed fractions using option 1

Ex) _____	1) $8\frac{4}{6} - 5\frac{1}{6} =$	2) $3\frac{7}{9} - 1\frac{5}{9} =$
3) $7\frac{5}{7} - 3\frac{3}{7} =$		5) $4\frac{6}{8} - 1\frac{3}{8} =$
6) $12\frac{9}{11} - 10\frac{8}{11} =$	7) $13\frac{4}{15} - 5\frac{6}{15} =$	4) $7\frac{9}{10} - 8\frac{4}{10} =$

Part 2

Subtract the mixed fractions using option 2

Ex) $6\frac{7}{8} - 2\frac{3}{8} = \frac{55}{8} - \frac{19}{8} = \frac{36}{8}$ or $4\frac{4}{8}$	1) $8\frac{7}{9} - 4\frac{3}{9} =$
2) $7\frac{4}{5} - 3\frac{2}{5} =$	3) $13\frac{8}{11} - 6\frac{3}{11} =$
4) $10\frac{11}{13} - 8\frac{6}{13} =$	5) $15\frac{12}{14} - 9\frac{9}{14} =$

Subtracting Fractions With Unlike Denominators

Part 1

Create common denominators and subtract the improper fractions

$$1) \frac{22}{6} - \frac{5}{4} = \frac{44}{12} - \frac{15}{12} = \frac{29}{12} \text{ or } 2\frac{5}{12}$$

$$2) \frac{9}{4} - \frac{8}{6} =$$

$$3) \frac{18}{4} - \frac{7}{6} =$$

$$4) \frac{8}{4} - \frac{10}{9} =$$

$$5) \frac{12}{5} - \frac{7}{6} =$$

$$6) \frac{21}{8} - \frac{5}{3} =$$

$$7) \frac{19}{9} - \frac{3}{2} =$$

$$8) \frac{11}{4} - \frac{7}{6} =$$

Part 2

Answer the word problems below

- 1) Steve wants to buy a larger aquarium for his fish. Option 1 holds $\frac{5}{6}$ of water. Option 2 holds $\frac{100}{3}$ litres of water.

- a) Which option holds more water?
b) How much more water does it hold?



- 2) Darren has a plank of wood that is $\frac{25}{100}$ cm long. He needs it to be $\frac{35}{25}$ cm long. How much should he cut off?



Exit Cards

Cut Out

Cut out the exit cards below and have students complete them at the end of class.

Name: _____

1) Subtract the mixed fractions

a) $8\frac{4}{6} - 5\frac{2}{6} =$

b) $12\frac{6}{14} - 6\frac{8}{14} =$

2) Solve the word problem

Emily used $\frac{3}{8}$ of a cup of flour and $\frac{1}{10}$ of a cup of sugar for her cookies. How much more flour was used than sugar?

Name: _____

1) Subtract the mixed fractions

a) $8\frac{4}{6} - 5\frac{2}{6} =$

b) $12\frac{6}{14} - 6\frac{8}{14} =$

2) Solve the word problem

Emily used $\frac{3}{8}$ of a cup of flour and $\frac{1}{10}$ of a cup of sugar for her cookies. How much more flour was used than sugar?

Name: _____

1) Subtract the mixed fractions

a) $8\frac{4}{6} - 5\frac{2}{6} =$

b) $12\frac{6}{14} - 6\frac{8}{14} =$

2) Solve the word problem

Emily used $\frac{3}{8}$ of a cup of flour and $\frac{1}{10}$ of a cup of sugar for her cookies. How much more flour was used than sugar?

Name: _____

1) Subtract the mixed fractions

a) $8\frac{4}{6} - 5\frac{2}{6} =$

b) $12\frac{6}{14} - 6\frac{8}{14} =$

2) Solve the word problem

Emily used $\frac{3}{8}$ of a cup of flour and $\frac{1}{10}$ of a cup of sugar for her cookies. How much more flour was used than sugar?

Repeated Addition & Multiplying Fractions

Part 1

Add and multiply the fractions below.

Addition Version	Multiplication Version
1) $\frac{4}{7} + \frac{4}{7} + \frac{4}{7} + \frac{4}{7} + \frac{4}{7} = \frac{20}{7}$ or $2\frac{6}{7}$	$5 \times \frac{4}{7} = \frac{20}{7}$ or $2\frac{6}{7}$
2) $\frac{1}{9} + \frac{1}{9} + \frac{1}{9} + \frac{1}{9} + \frac{1}{9} =$	
3) $\frac{2}{3} + \frac{2}{3} + \frac{2}{3} + \frac{2}{3} + \frac{2}{3} =$	
4) $\frac{3}{6} + \frac{3}{6} + \frac{3}{6} + \frac{3}{6} + \frac{3}{6} =$	
5) $\frac{4}{9} + \frac{4}{9} + \frac{4}{9} + \frac{4}{9} + \frac{4}{9} + \frac{4}{9} =$	
6) $\frac{5}{10} + \frac{5}{10} + \frac{5}{10} + \frac{5}{10} + \frac{5}{10} + \frac{5}{10} + \frac{5}{10} =$	
7) $\frac{3}{7} + \frac{3}{7} + \frac{3}{7} + \frac{3}{7} + \frac{3}{7} + \frac{3}{7} + \frac{3}{7} =$	

Part 2

Answer the word problems below using an addition or multiplication sentence.

1) Jerry made 5 pizzas. Each of the pizzas have $\frac{2}{7}$ cups of cheese. How much cheese do all 5 pizzas have in total?

Addition Sentence	Multiplication Sentence

2) Helen buys 9 bags of chips. Each bag is $\frac{4}{9}$ of a kg. How many kilograms are all 9 bags combined?

Addition Sentence	Multiplication Sentence

Multiply Whole Numbers by Fractions – Number Line**Questions**

Use the number line by skip counting to find the answer

1) $8 \times \frac{1}{10} =$



2) $10 \times \frac{1}{10} =$



3) $7 \times \frac{1}{8} =$

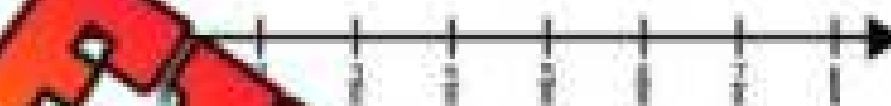

4) $5 \times \frac{1}{6} =$



5) $4 \times \frac{1}{5} =$



6) $7 \times \frac{1}{11} =$

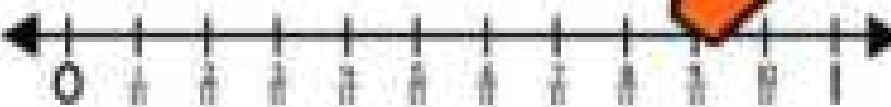

7) $8 \times \frac{1}{9} =$



8) $6 \times \frac{1}{7} =$



Multiply Whole Numbers by Fractions

Questions:

Multiply the whole numbers by the fractions below. Write the answer as an improper fraction.

1) $4 \times \frac{3}{4} = \frac{12}{4}$

2) $5 \times \frac{2}{5} =$

3) $8 \times \frac{4}{8} =$

4) $9 \times \frac{1}{10} =$

5) $4 \times \frac{4}{7} =$

6) $6 \times \frac{6}{8} =$

7) $7 \times \frac{4}{6} =$

8) $4 \times \frac{2}{5} =$

9) $7 \times \frac{2}{5} =$

10) $3 \times \frac{6}{7} =$

11) $3 \times \frac{8}{10} =$

12) $2 \times \frac{2}{5} =$

13) $5 \times \frac{2}{6} =$

14) $5 \times \frac{3}{7} =$

15) $9 \times \frac{5}{7} =$

16) $6 \times \frac{3}{7} =$

17) $7 \times \frac{6}{8} =$

18) $11 \times \frac{2}{9} =$

Multiplying Fractions – Area Models

We can represent two fractions using the same area model. Doing so will allow us to determine the product when we multiply two fractions together.

$$\frac{2}{3} \times \frac{1}{4} = \frac{2}{12}$$

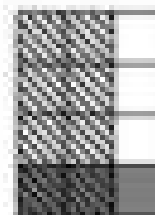

Example

Step 1: Divide the area model into thirds horizontally to represent $\frac{2}{3}$

Step 2: Draw diagonal lines that fill in two-thirds of the area model

Step 3: Divide the area model into fourths vertically to represent $\frac{1}{4}$

Step 4: Shade one-fourth of the area model

Step 5: Count how many squares overlap compared to the total number of squares

Questions: Find the product using an area model. Steps 1-4 have been done for you

1)

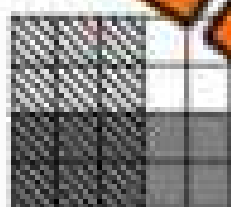

$$\frac{3}{5} \times \frac{2}{4} = \underline{\hspace{2cm}}$$

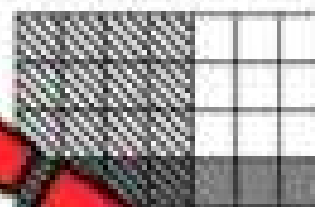

$$\frac{5}{9} \times \frac{3}{5} = \underline{\hspace{2cm}}$$

3)

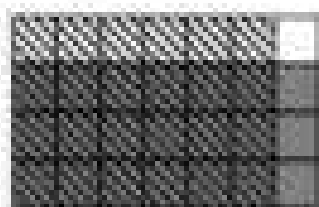

$$\frac{6}{7} \times \frac{3}{4} = \underline{\hspace{2cm}}$$

4)

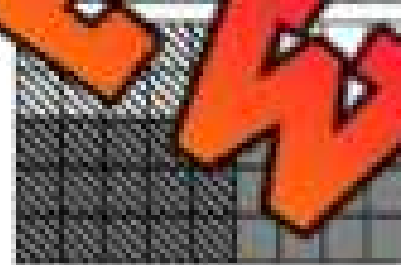

$$\frac{5}{9} \times \frac{3}{5} = \underline{\hspace{2cm}}$$

5)

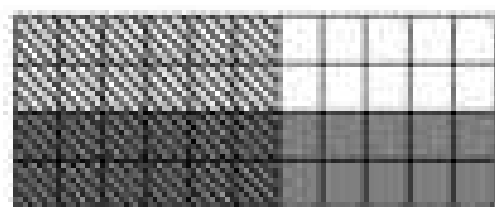

$$\frac{6}{11} \times \frac{2}{4} = \underline{\hspace{2cm}}$$

6)

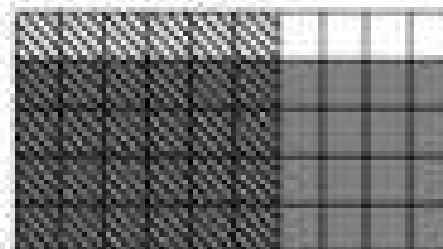

$$\frac{6}{10} \times \frac{4}{5} = \underline{\hspace{2cm}}$$

Multiplying Fractions – Area Models

The area models below have been divided to represent the fractions.

Directions:

- 1) Use diagonal lines to represent the first fraction
- 2) Shade in the area model to represent the second fraction
- 3) Write the answer

Questions Find the product using the area models below

1)

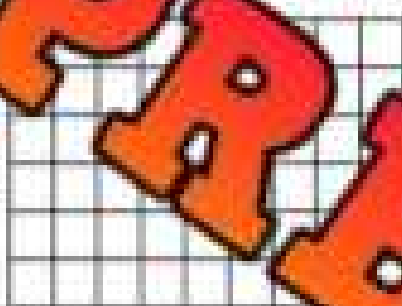

$$\frac{7}{9} \times \frac{5}{6} = \underline{\hspace{2cm}}$$

2)

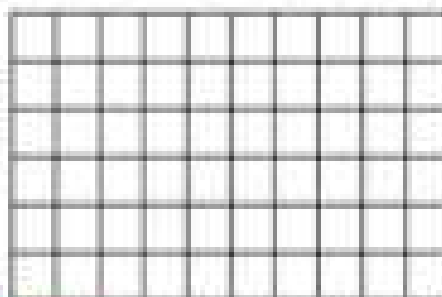

$$\frac{3}{6} \times \frac{4}{6} = \underline{\hspace{2cm}}$$

3)

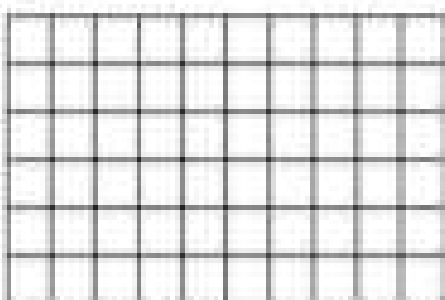

$$\frac{4}{10} \times \frac{4}{6} = \underline{\hspace{2cm}}$$

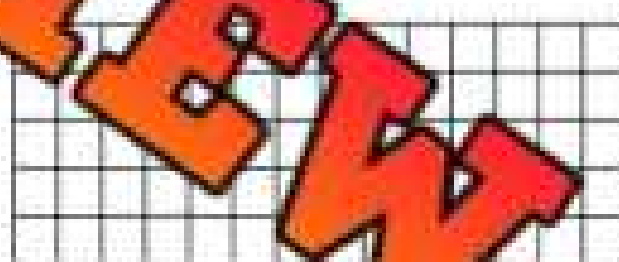

$$\frac{6}{14} \times \frac{3}{6} = \underline{\hspace{2cm}}$$

5)

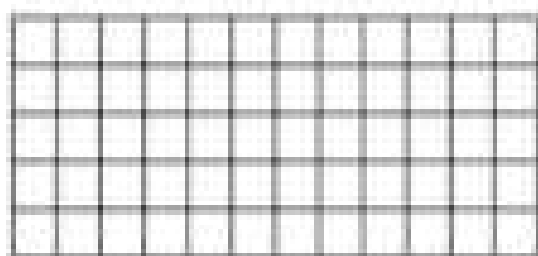

$$\frac{8}{12} \times \frac{4}{5} = \underline{\hspace{2cm}}$$

6)

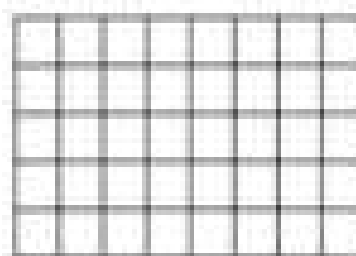

$$\frac{5}{8} \times \frac{2}{5} = \underline{\hspace{2cm}}$$

Multiplying Fractions – Word Problems

Questions

Find the products of the fractions below

1) Axel and Jasmine raced for 5 minutes. In the 5 minutes, Axel ran $\frac{8}{11}$ of a kilometre. Jasmine ran $\frac{2}{3}$ times as far as Axel. How far did Jasmine run?



2) Faith and Ember had sandwiches. Faith ate $\frac{1}{4}$ of her sandwich. Ember wasn't that hungry, so she ate $\frac{1}{5}$ as much as Faith ate. How much of her sandwich did Ember eat?



3) Laura completed $\frac{8}{11}$ of a marathon in the same time that Adalyn finished $\frac{2}{3}$ times as much of the race that Laura finished. How much of a marathon did Adalyn finish?



4) Atlas and Evie volunteered one day. Atlas spent $\frac{3}{4}$ of the 8-hour workday volunteering. Evie volunteered $\frac{1}{3}$ the amount of time that Atlas volunteered.

- What fraction of the workday did Evie volunteer?
- How much time did Atlas volunteer?
- How much time did Evie volunteer?



Multiplying Mixed Fractions

How to multiply mixed fractions

- 1) Convert the mixed fractions to improper fractions.
- 2) Multiply the improper fractions.
- 3) Convert the improper fraction back to a mixed fraction.
- 4) Simplify if necessary.

$$2\frac{2}{3} \times 2\frac{2}{4} = \frac{8}{3} \times \frac{10}{4} = \frac{80}{12} \text{ or } 6\frac{8}{12} \text{ or } 6\frac{2}{3}$$

Part 1 Find the products of the fractions below. Simplify the fractions.

1) $3\frac{1}{3} \times 2\frac{2}{4} =$

2) $4\frac{2}{5} \times 7\frac{3}{6} =$

3) $5\frac{1}{2} \times 6\frac{3}{7} =$

4) $9\frac{2}{4} \times 4\frac{7}{9} =$

5) $10\frac{3}{7} \times 7\frac{2}{3} =$

6) $1\frac{1}{2} \times 2\frac{1}{3} =$

7) $12\frac{1}{5} \times 5\frac{2}{3} =$

8) $8\frac{1}{4} \times 3\frac{1}{2} =$

Part 2 Answer the word problems below.

1) Hadley ran $3\frac{1}{2}$ km. Freya ran $2\frac{2}{3}$ km times further. How far did Freya run?



2) Parker made tomato and chicken noodle soup. He made $2\frac{3}{4}$ kg of tomato-soup and $\frac{4}{5}$ times more chicken noodle soup. How much chicken noodle soup did he make?



Dividing Whole Numbers by Fractions - Visuals

How many times does $\frac{2}{4}$ fit into 6? How many times can you shade 2 parts?

$$6 \div \frac{2}{4} = 12$$

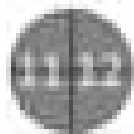
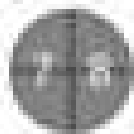
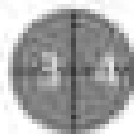
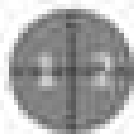

Questions

How many times does the fraction fit into the whole number?

1)

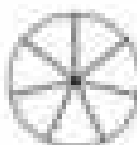

2)

$$6 \div \frac{3}{5} =$$



3)

$$6 \div \frac{6}{7} =$$



4)

$$5 \div \frac{2}{4} =$$

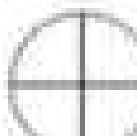

5)

$$8 \div \frac{4}{5} =$$

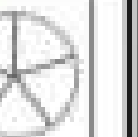
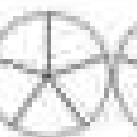
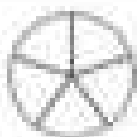

6)

$$8 \div \frac{4}{7} =$$

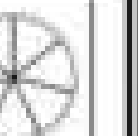
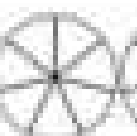

7)

$$6 \div \frac{3}{8} =$$

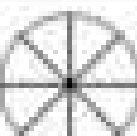
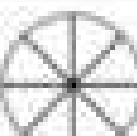
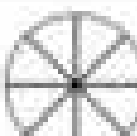
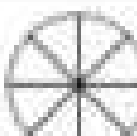
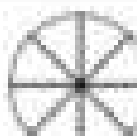

Dividing Fractions Using Models

Dividing Fractions

When we divide a fraction by its unit fraction, we should think, "how many counts of the unit are in the fraction (i.e., how many two-eighths are in six-eighths?)"

Solution – We can see that there are 3 two-eighths in six-eighths.

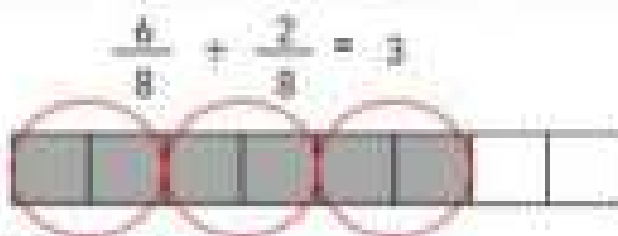

Questions _____ fraction bar. How many times does the divisor fit into the dividend?

1)



$$\frac{4}{8} \div \frac{2}{8} = \underline{\quad}$$

2)



$$\frac{9}{10} \div \frac{3}{10} = \underline{\quad}$$

3)



$$\frac{4}{8} \div \frac{1}{8} = \underline{\quad}$$

4)



$$\frac{9}{10} \div \frac{3}{10} = \underline{\quad}$$

5)



$$\frac{8}{10} \div \frac{2}{10} = \underline{\quad}$$

6)



$$\frac{16}{20} \div \frac{4}{20} = \underline{\quad}$$

7)

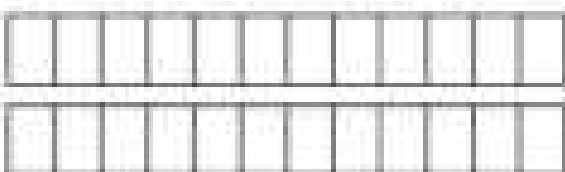

$$\frac{24}{24} \div \frac{4}{24} = \underline{\quad}$$

8)

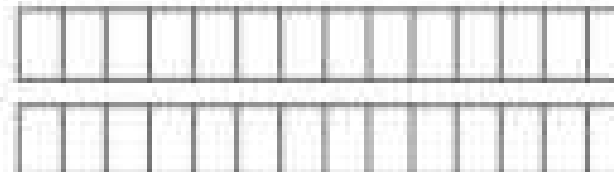

$$\frac{21}{28} \div \frac{3}{28} = \underline{\quad}$$

Dividing Fractions – Word Problems**Questions**

Find the answers of the fractions below

1) Howard can run a kilometre in $\frac{2}{8}$ of an hour. How many kilometres can he run in $\frac{3}{4}$ of an hour?



2) Jayce bought a sub sandwich that is $\frac{9}{10}$ of a metre long. He wants to cut it into smaller pieces that are $\frac{3}{30}$ of a metre long. How many sandwiches will he have?



3) Hugh has a goal of exercising $1\frac{2}{4}$ hours a day. He has done several runs today. His runs take him $\frac{4}{6}$ of an hour. How many runs does he have to go on?

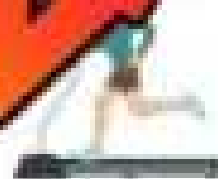

4) Zara loves to read. She can read a book in $\frac{2}{7}$ of an hour. If she only had $1\frac{10}{12}$ of an hour to read, how many books could she read?



Dividing Mixed Fractions

How to divide mixed fractions

1) Convert the mixed fractions to improper fractions

Question	Improper	K, S, F	Answer	Simplified
$4\frac{2}{3} \div 3\frac{1}{2}$	$\frac{14}{3} \div \frac{10}{2}$	$\frac{14}{3} \times \frac{2}{10} = \frac{28}{30}$	$1\frac{14}{30}$	$1\frac{2}{3}$

2) Use the Keep, Switch, Flip (K,S,F) method to change the question to multiplication

3) Convert the answer back to a mixed fraction and simplify if necessary

Part 1 Write the answers of the fractions below. Simplify the fractions.

Question	Improper	K, S, F	Answer	Simplified
1) $6\frac{3}{4} \div 2\frac{1}{2}$				
2) $5\frac{1}{6} \div 4\frac{1}{6}$				
3) $8\frac{3}{8} \div 3\frac{5}{8}$				
4) $7\frac{1}{8} \div 4\frac{1}{8}$				
5) $6\frac{1}{4} \div 3\frac{3}{4}$				
6) $8\frac{3}{9} \div 2\frac{2}{3}$				

Part 2 Answer the word problem

Jasper ordered $5\frac{3}{4}$ loads of mulch to fill gardens around his property. Each garden requires $1\frac{2}{3}$ loads of mulch. How many gardens can he fill with mulch?



Unit Test - Fractions

Part 1

Convert the mixed numbers to improper fractions

$$1) 7 \frac{2}{4} =$$

$$2) 4 \frac{1}{5} =$$

$$3) 5 \frac{3}{5} =$$

Part 2

Convert the improper fractions to mixed numbers

$$1) \frac{27}{4} =$$

$$\frac{26}{5} =$$

$$3) \frac{34}{6} =$$

Part 3

Add and subtract fractions using the models

$$1) \frac{6}{8} + \frac{4}{8} =$$

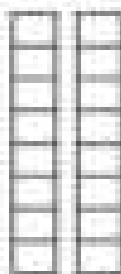

$$2) \frac{7}{11} + \frac{4}{11} =$$



$$3) \frac{8}{9} - \frac{5}{9} =$$



$$4) \frac{10}{11} - \frac{7}{11} =$$



Part 4

Create common denominators and then add/subtract the fractions below

1) $\frac{5}{7} + \frac{3}{8} =$

2) $\frac{5}{14} + \frac{2}{4} =$

3) $\frac{6}{8}$

4) $\frac{6}{7} + \frac{2}{4} =$

5) $\frac{11}{15} - \frac{2}{5} =$

6) $\frac{3}{5} - \frac{3}{8} =$

7) $\frac{10}{18} - \frac{5}{9} =$

$\frac{1}{4} =$

Part 5

Add and subtract the mixed fractions

1) $5\frac{2}{8} + 2\frac{4}{8} =$

2) $4\frac{3}{8} + 4\frac{5}{8} =$

3) $11\frac{3}{8} + 10\frac{2}{8} =$

4) $7\frac{6}{10} + 4\frac{6}{10} =$

5) $3\frac{4}{7} - 2\frac{3}{7} =$

6) $13\frac{8}{15} - 8\frac{3}{15} =$

7) $12\frac{3}{8} - 5\frac{4}{7} =$

8) $8\frac{4}{6} - 4\frac{4}{10} =$

Part 9

Solve the division questions below

1) $\frac{7}{8} \div \frac{3}{12} =$

2) $\frac{9}{11} \div \frac{3}{7} =$

3) $\frac{5}{6} \div \frac{2}{3} =$

4) $\frac{8}{9} \div \frac{4}{6} =$

5) $8 \div \frac{1}{2} =$

6) $5 \div \frac{7}{8} = \text{---} \times \text{---} =$

7) $7 \div \frac{2}{5} = \text{---} \times \text{---} =$ $\frac{4}{8} \div \frac{4}{8} = \text{---} \times \text{---} =$

Part 10

Answer the word problems below

1) Scotty can run a kilometre in $\frac{4}{8}$ of an hour. How long can he run in $\frac{3}{4}$ of an hour?

2) Quinn bought 5 cans of tomato soup. Each can holds $\frac{8}{9}$ litres of soup. How many litres of soup do all 5 cans hold?

Ratio In 3 Ways

Part 1

Write the ratios for the questions below

1) Ratio of 35 balls to 76 strikes.	Words: _____ Ratio: _____ Fraction: _____
2) Ratio of 3 dunks to three pointers.	Words: _____ Ratio: _____ Fraction: _____
3) Ratio of 10 cars to 3 trucks.	Words: _____ Ratio: _____ Fraction: _____
4) Ratio of 2 coffees to 6 waters.	Words: _____ Ratio: _____ Fraction: _____
5) Ratio of sitting for 30 minutes to standing for 60.	Words: _____ Ratio: _____ Fraction: _____
6) Ratio of 1 grade 8 to 1 grade 7.	Words: _____ Ratio: _____ Fraction: _____
7) Ratio of 3 apples to 1 shot.	Words: _____ Ratio: _____ Fraction: _____
8) Ratio of 2 treats to 1 healthy snack.	Words: _____ Ratio: _____ Fraction: _____

Part 2

Answer the questions below

- 1) A baseball pitcher threw a ratio of 1 ball to 3 strikes. The pitcher threw 75 strikes. How many balls did they throw?



- 2) A hockey player has a ratio of 1 goal for every 8 shots they took. The player scored 5 goals today. How many shots did they take?



Equivalent Ratios – Scaling Up and Down

Questions

Circle two equivalent ratios for each of the questions below

1) 5:10	$\frac{1}{3}$	2:5	1 to 2	3:5	$\frac{10}{20}$
2) 4:17	1:3	8 to 36	12:36	$\frac{2}{3}$	8:36
3) $\frac{7}{16}$	2:32	3:32	18:16	3:8	
4) $\frac{3}{6}$	1:4	5:10	2:8	5 to 15	
5) 9:12	$\frac{2}{3}$	3:4	$\frac{27}{6}$	18:48	
6) 6:8	2:4	$\frac{1}{3}$	3:4	$\frac{60}{15}$	
7) 4 to 10	1:3	2:6	$\frac{3}{7}$	2 to 5	12:30
8) 15:20	5 to 10	10:15	3:4	30:50	$\frac{45}{60}$
9) $\frac{25}{40}$	1:3	5 to 8	50:80	3 to 6	10:30
10) 8:12	5 to 8	7:11	$\frac{4}{6}$	28:42	24 to 36

Simplifying Proportions

Questions

Write a ratio in its simplest form for each of the situations below.

1) A farm sells 15 apples for every 10 bananas.

2) A restaurant sells 25 sandwiches for every 5 steaks.



3) Ben counted 30 vehicles driving on his road. 21 of the vehicles were cars and 9 were trucks.

4) Owen owns 4 racing video games and 3 adventure games.



5) Hugh counted his socks and discovered all had 5 black socks and 25 white socks.

6) A hockey team practices 36 times a year and wins 12 games.

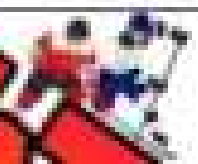

7) A café sells 18 coffees for every 6 teas.

8) Silas can perform 21 push-ups and 7 pull-ups.



9) Allison noticed that 36 songs played on a jukebox were rock songs and 48 songs were pop songs.

10) At Wellington Intermediate School, a survey determined that 96 students took a bus to school and 128 students walked.



Proportional vs Non-Proportional Relationship

A **proportional relationship** is when two variables change at the same rate.

Example - 1 cookie per 1 student ($1/1$) is proportional to 10 cookies per 10 students ($10/10$). Both variables (cookie and student), were multiplied by the same number - 10.

A **non-proportional relationship** is when two variables do not change at the same rate.

Example - \$100 per 1 month ($1/100$) is different than \$500 per 7 months ($500/7$)

Question: Which relationships proportional or non-proportional?

1) $\frac{9}{2}$ and $\frac{18}{4}$ Proportional Non-Proportional	2) $\frac{2}{6}$ and $\frac{5}{15}$ Proportional Non-Proportional
3) $\frac{14}{6}$ and $\frac{98}{35}$ Proportional Non-Proportional	4) $\frac{1}{2}$ and $\frac{75}{125}$ Proportional Non-Proportional
5) $\frac{5}{8}$ and $\frac{45}{64}$ Proportional Non-Proportional	6) $\frac{1}{2}$ and $\frac{1}{2}$ Proportional Non-Proportional
7) $\frac{12}{7}$ and $\frac{84}{56}$ Proportional Non-Proportional	8) $\frac{7}{3}$ and $\frac{210}{90}$ Proportional Non-Proportional
9) $\frac{60}{7}$ and $\frac{300}{35}$ Proportional Non-Proportional	10) $\frac{8}{17}$ and $\frac{56}{102}$ Proportional Non-Proportional
11) $\frac{9}{22}$ and $\frac{54}{132}$ Proportional Non-Proportional	12) $\frac{15}{35}$ and $\frac{120}{245}$ Proportional Non-Proportional

Proportional vs Non-Proportional Relationship

When representing variables, we can use a table to determine if the relationship is proportional or non-proportional.

Example - Erica earned a pay cheque each week from her employer. Her earnings go up \$250 each week, which makes the relationship between weeks and earnings proportional.

Weeks (x)	1	2	3	4	5	6
Earnings (y)	250	500	750	1000	1250	1500

Question: Are the following relationships proportional or non-proportional?

1)

x	1	2	3	4
y	75	150	225	300

Proportional

Non-Proportional

2)

x	5	10	15	20
y	50	100	150	200

Proportional

Non-Proportional

3)

x	3	6	9	12
y	15	30	45	60

Proportional

Non-Proportional

4)

x	12	14	20
y	7	114	134

Proportional

Non-Proportional

5)

x	10	20	30	40
y	70	140	210	280

Proportional

Non-Proportional

6)

x	10	20	30
y	200	400	1200

Proportional

Non-Proportional

7)

x	20	40	60	80
y	5	10	15	20

Proportional

Non-Proportional

8)

x	7	14	21	28
y	21	42	64	84

Proportional

Non-Proportional

9)

x	1	11	21	31
y	10	110	210	310

Proportional

Non-Proportional

10)

x	5	15	25	35
y	100	450	750	1050

Proportional

Non-Proportional

Proportional Relationship - Graph

When a proportional relationship is represented on a graph, the result is a straight line. This is called a linear graph.

Example:

Kim drove from Kingston to Toronto. She kept track of her distance every hour.

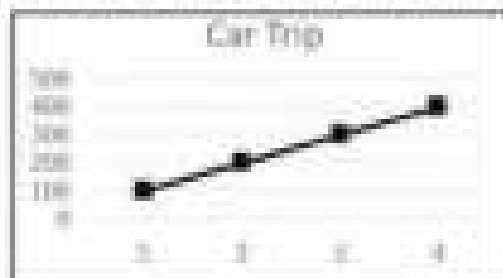

Hours	Distance (km)
1	100
2	200
3	300
4	400

Questions: Use the table of values based on the graph. Is the relationship proportional?

1)

x	y
1	
2	
3	
4	

Proportional



Non

2)

x	y
5	
10	
15	
20	

Proportional



Non-Proportional

3)

x	y
15	
30	
45	
60	

Proportional



Non-Proportional

Proportional Relationship - Graph

Questions

Draw a line graph that represents the table. Is it a proportional relationship?

1)

x	y
1	5
2	20
3	35

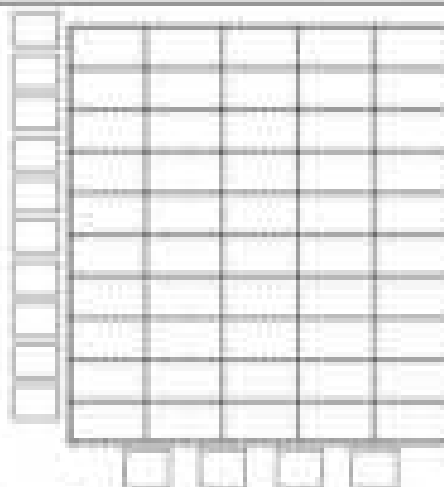

Proportional

Non-Proportional

2)

x	y
2	4
4	12
6	18
8	30

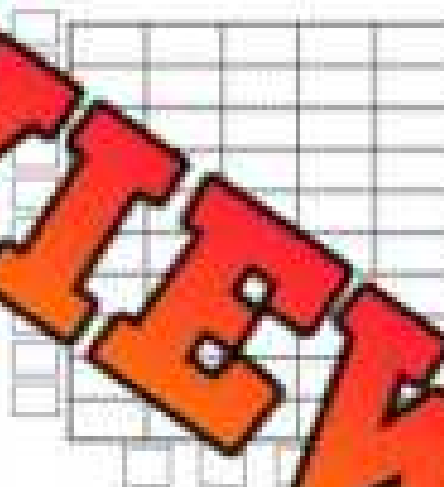

Proportional

Non-Proportional

3)

x	y
5	60
10	100
15	140
20	180



Proportional

Non-Proportional

Proportional Relationship – Pizza Party

Questions

Solve the problem below

Reagan is buying pizza for a pizza party. She wants to have 3 slices of pizza for each person coming to the party. The graph below represents the relationship between the number of slices of pizza and the number of party goers.

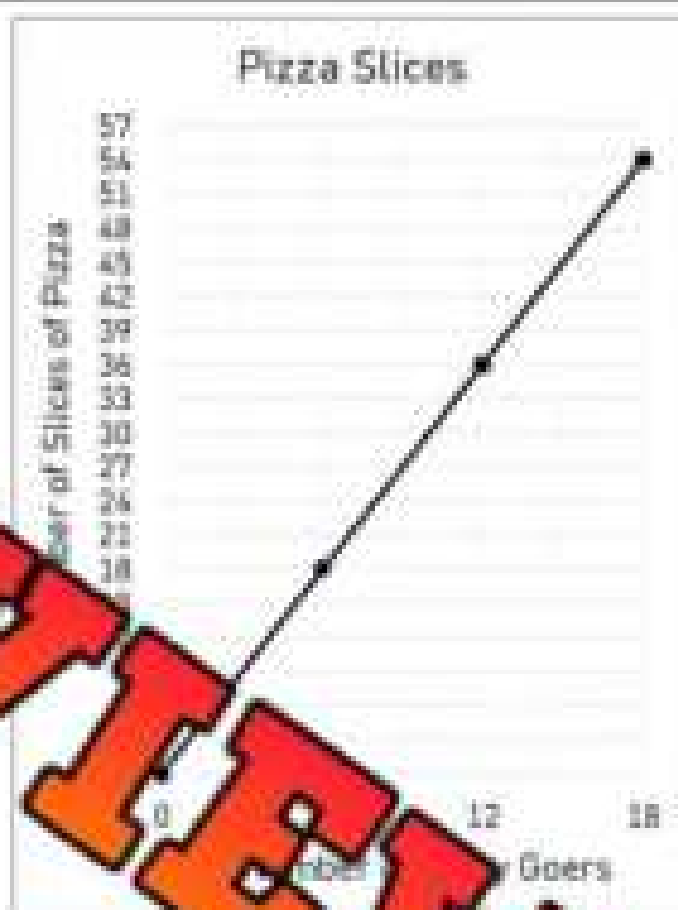

- | | |
|---|--|
| 1) Is the graph proportional or non-proportional? | |
| 2) What is the unit rate? (number of slices per person) | |
| 3) How many pizza slices would she need for 9 people? | |
| 4) Reagan bought 63 slices of pizza. How many people is she expecting? | |
| 5) Use the graph to determine how many pizza slices she would need for 13 people? | |
| 6) Use the graph to determine how many slices she would need for 17 people? | |
| 7) If Reagan bought 147 slices of pizza, how many people was she expecting? | |

Proportional Relationship – Earnings

Questions

Draw a line graph and fill in the table to represent the situation

Daniel earns \$350 a week from his job. Fill in his earnings over a 10-week period and graph his earnings.



Weeks	Savings
1	
2	
3	
4	
5	
6	
7	
8	
9	
10	

1) Is the relationship between weeks and savings proportional or non-proportional?

2) How much did Daniel earn after 5 weeks?

3) What is the unit rate? (earnings per week)

4) How much does he earn after 3.5 weeks?

5) After 20 weeks, how much would Daniel have earned?

6) After 25 weeks, Daniel saved all his money and then spent \$2100. How much does he have now?

Proportional Reasoning - Quiz

Part 1

Write the ratios for the questions below

1) Ratio of 41 balls to 67 strikes.

Words: _____

Ratio: _____

Fraction: _____

3) Ratio of 27 cars to 12 trucks.

Words: _____

Ratio: _____

Fraction: _____

2) Ratio of green apples to 15 red apples.

Words: _____

Ratio: _____

Fraction: _____

4) Ratio of 25 students to 1 teacher.

Words: _____

Ratio: _____

Fraction: _____

Part 2

Circle the ratio that is equivalent to each of the questions below

1) 3 to 9

$\frac{1}{3}$

2:5

1:3

9:27

$\frac{10}{33}$

2) 4:16

1:3

1 to 4

$\frac{1}{6}$

1

12:48

3) $\frac{5}{20}$

2:8

6:40

7:28

3:1

10:50

Part 3

Answer the word problems below

There are 35 students in a grade 8 class. The ratio of girls to boys is 3:2.

- Write the ratio in words and as a fraction.
- How many boys are in the class?
- How many girls are in the class?

Part 4

Are the relationships proportional or non-proportional?

1) $\frac{8}{2}$ and $\frac{18}{4}$

Proportional

Non-Proportional

2) $\frac{4}{7}$ and $\frac{16}{28}$

Proportional

Non-Proportional

3) $\frac{16}{5}$ and $\frac{64}{20}$

Proportional

Non-Proportional

4) $\frac{9}{12}$ and $\frac{81}{109}$

Proportional

Non-Proportional

Part 5

Are the relationships proportional rates by determine the value of the variable

1) $\frac{3}{8}$ and $\frac{18}{r}$

 $r =$ _____

2) $\frac{2}{7}$ and $\frac{m}{63}$

 $m =$ _____

3) $\frac{11}{t}$ and $\frac{121}{44}$

 $t =$ _____

4) $\frac{1}{3}$ and $\frac{y}{40}$

 $y =$ _____

5) $\frac{15}{6}$ and $\frac{185}{p}$

 $p =$ _____

6) $\frac{1}{2}$ and $\frac{1}{q}$

 $q =$ _____

Part 6

Are the relationships proportional or non-proportional?

1)	x	1	2	3	4
	y	33	66	99	132

Proportional

Non-Proportional

2)	x	5	10	15	20
	y	45	90	135	175

Proportional

Non-Proportional

3)	x	3	6	9	12
	y	45	130	195	260

Proportional

Non-Proportional

4)	x	8	12	16	20
	y	125	250	375	500

Proportional

Non-Proportional

Part 7

Draw a line graph and fill in the table to represent the situation

Stuart earns \$225 a week from his job. Fill in his earnings over a 10-week period and graph his earnings.



1) Is the relationship between week and savings proportional or non-proportional?

2) How much did Stuart earn after 5 weeks?

3) What is the unit rate? (earnings per week)

4) How much does he earn after 4.5 weeks?

5) After 20 weeks, how much would Stuart have earned?

6) After 30 weeks, Stuart saved all his money and then spent \$2650. How much does he have now?

Grade 8

C1. Patterns and Relationships

	Curriculum Expectations	Pages That Cover the Expectations
C1.1	identify and compare a variety of repeating, growing, and shrinking patterns, including patterns found in real-life contexts, and compare linear growing and shrinking patterns on the basis of their constant rates and initial values	5 – 7, 11, 39 – 49, 52 – 57, 60 – 61
C1.2	create and translate repeating, growing, and shrinking patterns involving rational numbers using various representations, including algebraic expressions and equations for linear growing and shrinking patterns	35 – 38, 42 – 43, 50 – 51, 58 – 59
C1.3	determine pattern rules and use them to extend patterns, make and justify predictions, and identify missing elements in growing and shrinking patterns involving rational numbers, and use algebraic representations of the pattern rules to solve for unknown values in linear growing and shrinking patterns	8 – 10, 17 – 34, 52 – 57, 60 – 61
C1.4	create and describe patterns to illustrate relationships among rational numbers	62 – 80

Pattern Rule – Input/Output Tables

Instructions

Fill in the input/output tables below:

Rule: add 4	
In	Out
112	
121	
143	

Rule: add 7	
In	Out
235	
251	
274	
295	

Rule: add 12	
In	Out
344	
361	
387	
408	

Rule: subtract 5	
In	Out
673	
688	
504	
527	

Rule: subtract 11	
In	Out
574	
592	
607	
646	

Rule: Subtract 9	
In	Out
778	
791	
807	
832	

Rule: multiply by 2	
In	Out
3	
12	
25	
41	

Rule: multiply by 3	
In	Out
5	
9	
13	
17	

Rule: multiply by 7	
In	Out
10	
12	

Rule: divide by 3	
In	Out
150	
240	
308	
390	

Rule: divide by 4	
In	Out
40	
80	
100	
240	

Rule: divide by 6	
In	Out
48	
72	
120	
180	

Algebra Jeopardy

Objective

What are we learning about?

To reinforce students' understanding of basic algebraic concepts and their application to solve simple equations and word problems in a fun and competitive game for

Mat

What do you need for the activity?

- Jeopardy board (see the next page)
- Buzzer or bell



Instructions

How will you complete the activity?

1. Print the Jeopardy board on the next page.
2. Divide the class into two teams.
3. Ask one team to go first by selecting a point value.
4. Read the question aloud from the point value.
5. The first team to ring the bell or buzzer gets to answer.
6. If they answer correctly, award them the points. If not, another team can answer.
7. Continue the game until all questions have been answered.
8. Tally the points to determine the winning team.
9. Conclude by discussing what they learned about the topic in the questions.

Jeopardy Questions

Ask students the questions below

\$100	\$200	\$300	\$400	\$500
87, 93, 99, _____	5.2, 5.5, 5.8, _____	Start at 1, multiply by 2 and add 1, what is the fourth term?	A plant grows 3.5 cm every week. If it was 12.3 cm tall at the start, how tall will it be after 3 weeks?	A builder lays 14.5 bricks per hour. If they have already laid 58 bricks, how many bricks will they have laid after 4 more hours of work?
140, 170, _____	1.2, 1.4, 1.6, _____	Start at 6, divide by 2 and add 1, what is the fifth term?	A rabbit population doubles every year. If there are 4 rabbits this year, how many will there be in 5 years?	A runner increases their distance by 1.75 km every week. If they started at 5.25 km, how far will they be running after 12 weeks?
82, 75, 68, _____	18.52, 18.09, 18.66, _____	Start at 4, multiply by 2 and add 1, what is the fifth term?	A car's speed increases every hour. It starts at 40 km/h and increases by 5 km/h every hour. How far will it travel in 6 hours?	A teacher's class size increases by 3.5 students every term. If the initial class size was 20 students, what will the class size be after 4 terms?
177, 148, 159, _____	35.7, 35.1, 34.5, _____	Start at 3, multiply by 4 and subtract 2, what is the fourth term?	A car travels 150 meters every day. It has a range of 5 meters per day. How far will it travel in total by the sixth day?	A car's value decreases by 15% every year. If the car's value was \$15,000, what will its value be after 6 years?
2, 10, 30, _____	17.3, 16.8, 16.3, _____	Start at 7, multiply by 2 and subtract 1, what is the third term?	A train travels 75 km in the first hour, 112.5 km in the second hour, and 150 km in the third hour. How far will it travel in total by the fifth hour?	A swimmer increases their training distance by 2.25 km every week. If they started at 4.75 km, how far will they be swimming after 8 weeks?
9, 18, 36, _____	11.32, 11.53, 11.74, _____	Start at 6, multiply by 5 and add 2, what is the fourth term?	A tree grows 3.5 inches in the first year, 7.5 inches in the second year, and 9.5 inches in the third year. How much will it have grown in total by the sixth year?	A bank account balance increases by \$75.50 every month due to interest. If the initial balance was \$2500, what will the balance be after 10 months?



Table of Values – Finding Term N

When finding a random term in a pattern, we can use a variable. Often n is used to take the place of the term number. When we use n , we can change the value to find the term value for any term number.

We can find the value for n by looking at the pattern between the term number and term value. To do this, we look across the table from the term number to the term value.

Practice Use the pattern rule when you look across the table of values.

Term Number	Term Value
1	6
2	12
3	18
4	
5	
8	

1) $6n$

Term Number	Term Value
1	3
2	8
3	13
4	18
5	23
9	

2) $5n - 2$

Term Number	Term Value
1	4
2	8
3	12
4	16

3) _____

Term Number	Term Value
1	9
2	16
3	23
4	30
5	
9	

4) _____

Term Number	Term Value
1	6
2	9
3	12
4	15
5	
10	

5) _____

Term Number	Term Value
1	4
2	10
3	16
4	22
5	
11	

6) _____

Table of Values – Finding Term N

Practice

Find the pattern rule when you look across the table of values.

Term Number	Term Value
1	10
2	15
3	20
4	25
5	30
8	

1) _____

Term Number	Term Value
1	7
2	17
3	27
4	37
5	

Term Number	Term Value
1	5
2	13
3	21
4	29
5	
11	

3) _____

Term Number	Term Value
1	5
2	15
3	25
4	35
5	
11	

4) _____

Term Number	Term Value
1	11
2	22
3	33
4	44
5	
11	

5) _____

Term Number	Term Value
1	5
2	14
3	23
4	32
5	

6) _____

Word Problem

Use a table of values and find the n^{th} term.

Owen's earnings are increasing in a pattern as he gets more customers. He earned \$100 in his first month, \$330 in his second month, \$1020 in the third month and \$3090 in the fourth month.

- a) How much will he earn in the 5th month if the pattern continues?

- b) How much will he earn in the 10th month if the pattern continues?

Using Algebraic Expressions

In the expression $6y + 5$, the 6 is the numerical coefficient of the variable and the 5 is the constant term. The variable is the y , which can represent any number.

Part 1 Use the algebraic expression to fill in the tables.

Term Number	Term Value
1	
2	
3	
4	
5	
6	

1) $5x + 2$

Term Number	Term Value
1	
2	
3	
4	
5	
6	

Term Number	Term Value
1	
2	
3	
4	
5	
11	

3) $t + 9$

Term Number	Term Value
1	
2	
3	
4	
5	
11	

4) $4n - 3$

Term Number	Term Value
1	
2	
4	
5	
10	
20	

5) $20 - x + 8$

Term Number	Term Value
1	
2	
4	
5	
11	

6) $7x - 6$

Part 2

Write 4 algebraic expressions using:
Variable = n Constant term = 12 Numerical coefficient = 4

1	
2	

3	
4	

Pattern Rule – Input/Output Tables

Instructions

Fill in the input/output tables below.

1)

In	Out
n	$3n$
1	
2	
3	
4	
5	

2)

In	Out
n	$3n + 2$
1	
2	
3	
4	

3)

In	Out
n	$4n - 4$
1	
2	
3	
4	
5	

4)

In	Out
x	$5x - 4$
10	
20	
30	
40	
50	

5)

In	Out
x	$2x + 1$
2	
4	
6	
8	
10	

6)

In	Out
x	$50 + x$
1	

7)

In	Out
p	$7p + 20$
20	
40	
60	
80	
100	

8)

In	Out
p	$10p - 15$
3	
6	
9	
12	
15	

9)

In	Out
p	$8p + 100$
5	
10	
15	
20	
25	

Exit Cards

Cut Out

Cut out the exit cards below and have students complete them at the end of class.

Name: _____

Fill in the input/output tables below.

In	Out
	$12x + 3$
3	
5	
7	
9	
11	

Name: _____

Fill in the input/output tables below.

In	Out
n	$12x + 3$
3	
5	
7	
9	

Name: _____

Fill in the input/output tables below.

In	Out
n	$12x + 3$
3	
5	
7	
9	
11	

Name: _____

Fill in the input/output tables below.

In	Out
n	$12x + 3$
3	
5	
7	
9	
11	

PREVIEW

Activity Title: Algebraic Adventure Hunt

Objective

What are we learning about?

To help students understand and practice filling in input/output tables using given expressions involving all four operations through a fun and engaging treasure hunt.

Materials

What will you need for the activity?

- Smartphones or tablets (if use a smartphone)
- Index cards
- Markers
- Small prizes (optional)
- Tape



Instructions

How will you complete this activity?

- 1) Cut out the index cards with the input/output tables provided. These will be the treasure hunt challenge questions.
- 2) Hide these cards around the classroom or in a designated area. You can tape them under chairs, desks, or tucked into non-obvious spots.
- 3) Divide the class into small teams and give each team a stopwatch.
- 4) Explain the game: each team will hunt for a card, fill in the table as quickly as they can, and return to you for verification.
- 5) Start the timer when you say "Go!" Each team rushes to find their first card.
- 6) When a team thinks they have the correct answer, they come back to you for verification. If they get it right, the teacher keeps the card. If the answer is wrong, they can try again or hide the card back in its original spot and find a new card.
- 7) The game continues until all cards are found or you call time. The team with the most correct answers wins.
- 8) Discuss the game, focusing on the concepts taught on the cards.

Instructions

Cut out the cards below.

In h	Out $h + 6 + 5$	In f	Out $5f - 51$	In e	Out $15e + 20$	In b	Out $b + 7 - 7$
12	15	15	5	5	70		
24	20	20	9	9	84		
36	25	25	13	13	98		
48	30	30			112		
60	35	35					
In k	Out $k + 4 - 18$	In g	Out $13g$	In c	Out $d + 9 - 5$	In c	Out $5c + 55$
112	7	7	5	3			
240	14	14	72	5			
304	21	21	99	7			
368	28	28	126	9			
432	35	35	153	11			

Growing Patterns

Instructions

How many blocks are in each term? Sketch the next 3 terms.

					
--	--	---	--	--	--

Figure Number	3	4	5	20	50
Number of Blocks					

1) Describe the recursive pattern?

2) What is the functional relationship between the variables?
(Write the expression)

3) How many blocks would the 100th figure have?

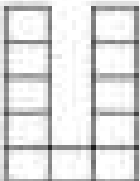
Number of Blocks

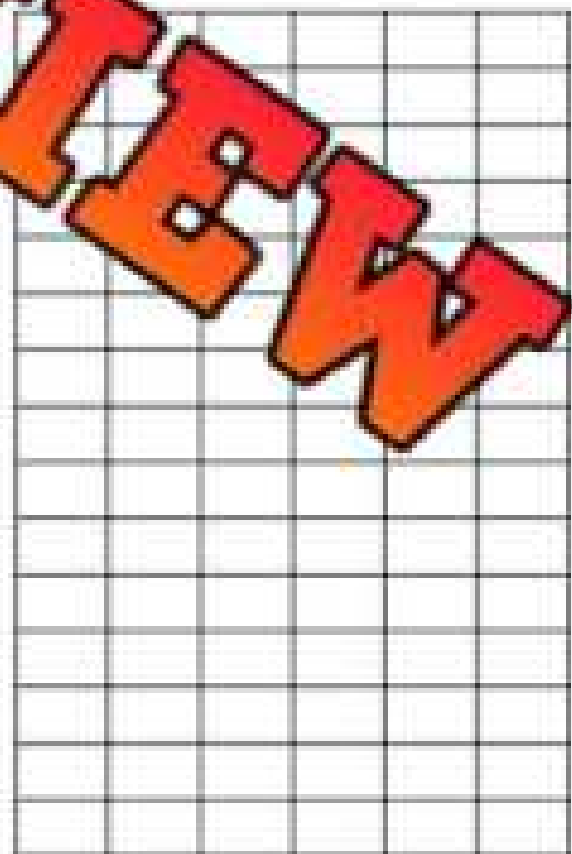

1 2 3 4 5

Figure Number

Matchstick Growing Patterns

Instructions

How many matchsticks are in each figure? Draw the next 2 figures.



F-1	F-2	F-3	F-4	F-5
				

Figure Number	3	4	5	10	20
Number of Matchsticks					

Questions

1) Write an expression that represents the functional relationship.

2) How many matchsticks will the 7th term have?

3) How many matchsticks will the 10th term have?

4) What figure would use 201 matchsticks?

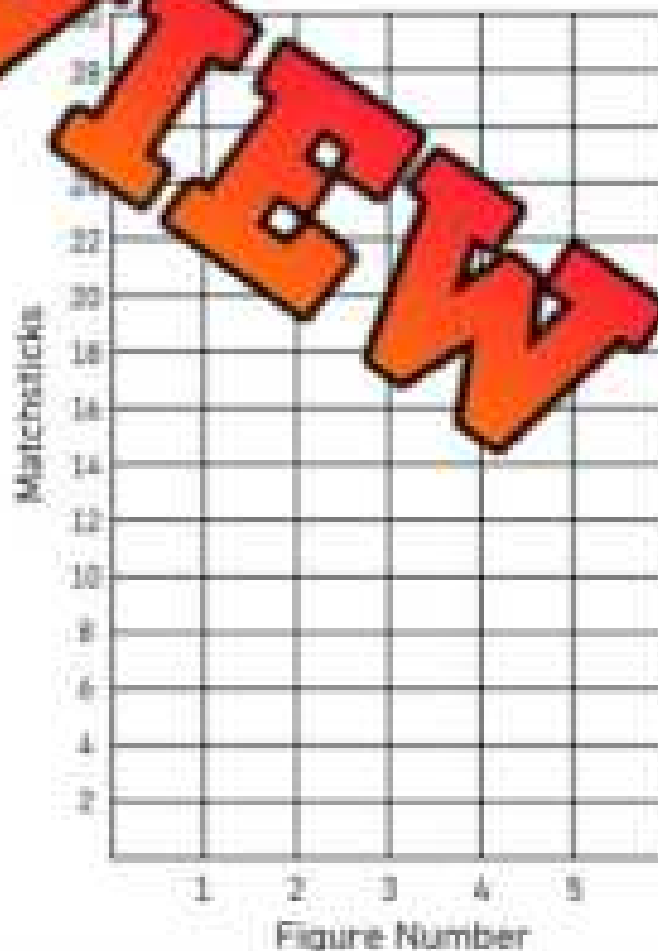

Shrinking Patterns

Instructions

How many grey blocks are in each term?

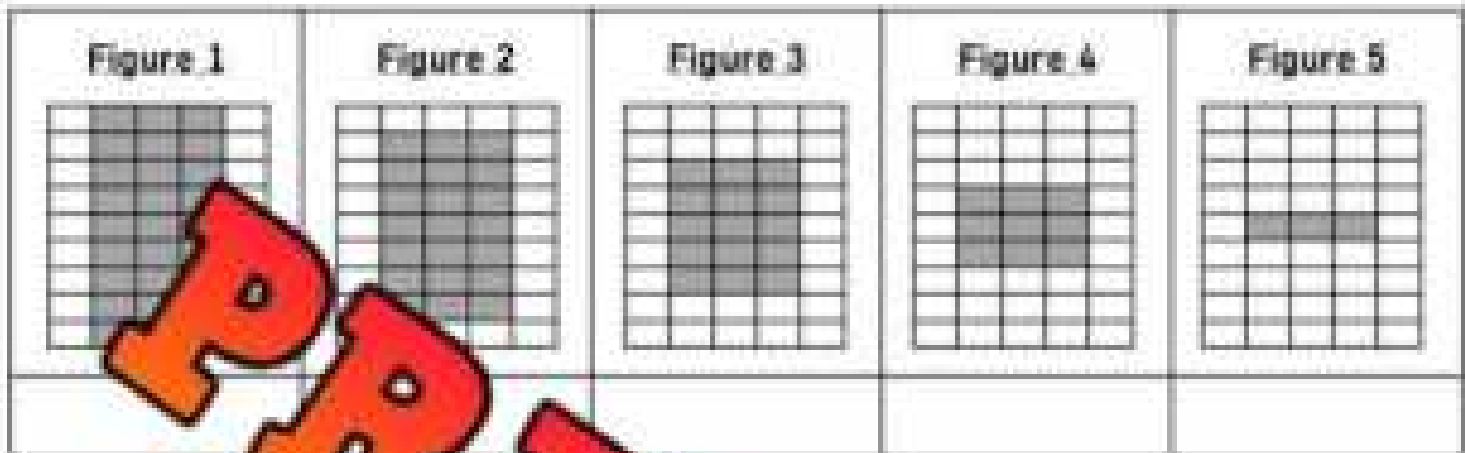

Figure Number	2	3	4	5
Number Of Grey Blocks				
Number Of White Blocks				
Number Of Total Blocks				

Write the functional relationship between the two-variables below
(Write the expression)

1) Figure number and grey blocks

2) Figure number and white blocks

Grey Blocks

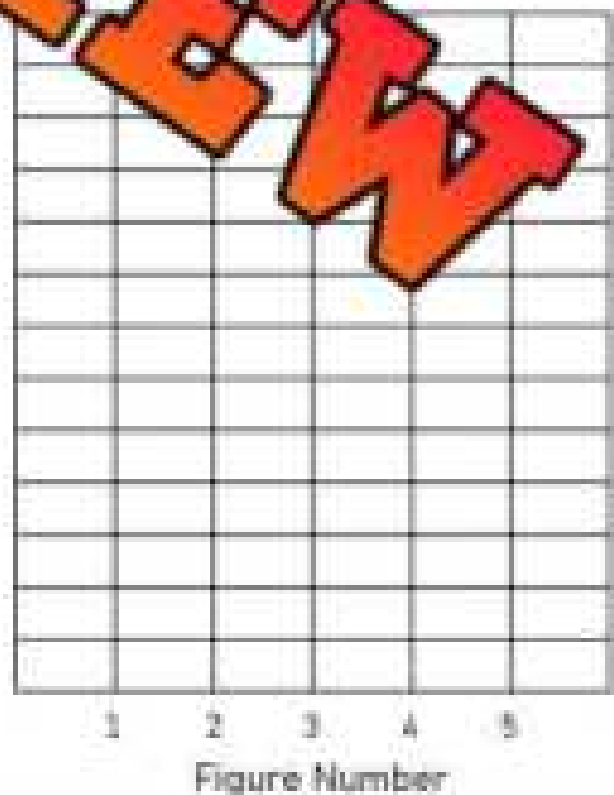

Two-Variable Linear Relationships

A two-variable linear relationship is when the increasing or decreasing of one variable causes a corresponding increase or decrease in the other variable. For example, driving 100km/hr would be a linear relationship between time driving and distance driven (for every hour driven, you travel 100km). As you drive longer, you travel further at a predictable distance.

Instructions Fill in the tables and answer the questions.



1) Chloé's allowance for today has been represented in the table below.

Hours Worked (x)	1	2	3	4	5	6	7	8
Money Earned (y)		44	65					

- a) Is the relationship between variables linear? Yes No
 b) What is the functional relationship between variables? _____

2) John sells cars. He earns a commission for every car he sells. His earnings for last week are represented in the table below. There were some days he did not earn commission.



Days Worked (x)	0	1	2	3	4	5	6	7
Money Earned (y)	0	140	280	420	560	900	1140	1280

- a) Is the relationship between variables linear? Yes No
 b) If you graphed this relationship, would the line be straight or curved? Explain.

3) Greg has a membership to a shopping website. He pays a yearly membership fee and orders the same thing each week for 10 weeks. His spending is displayed below.

Weeks (x)	0	1	2	3	4	5	6	7
Money Spent (y)	50	80	110	140	170	200	230	260

- a) Is the relationship between variables linear? Yes No
 b) What is the functional relationship between variables? _____
 c) If you graphed this relationship, would the line be straight or curved? Explain.

Two-Variable Linear Relationships



Instructions

Answer the question below.

1) At an ice cream shop, you pay for the cone and then more money for every scoop you add.

Scoops (x)	0	1	2	3	4	5
Cost (y)	\$2.00	\$2.50	\$3.00	\$3.50	\$4.00	\$4.50

a) What is the functional relationship between the two variables (algebraic expression)?

b) How much would it cost to buy _____ scoops?

c) How much would it cost to buy _____ scoops on a cone?

2) It costs \$15 for admission to the fair. Once inside, you pay for each additional ride you go on.

Rides (x)	0	1	2	3	4	5
Total Cost (y)	\$15.00	\$17.50	\$20.00	\$22.50	\$25.00	\$27.50

a) What is the functional relationship between the two variables (algebraic expression)?

b) How much would it cost to go on 50 rides?

3) Roger rents a truck and pays a set rate for every 10km he drives.

KM Driven (x)	0	10	20	30	40	50	60	70	80
Cost (y)	\$50	\$55	\$60	\$65	\$70	\$75	\$80	\$85	\$90

a) What is the functional relationship between the two variables (algebraic expression)?

b) How much would it cost to drive 250km?

PREVIEW

Reading a Linear Pattern - Graph

A linear pattern displays a constant rate of change. The pattern increases or decreases by the same amount each time.

Instructions

Continue the line on the graph and fill in the table of values.



1) Draw the toothpick pattern below for the graph/table of values. Use any design you'd like.

Term 1	Term 2	Term 3	Term 4	Term 5

2) What is the constant rate of change?

Linear and Non-Linear Patterns

Not all patterns are linear. Some patterns increase/decrease by the same amount each time, while others grow/shrink at different rates. When the pattern grows or shrinks by different amounts, it is called **non-linear**.

Instruction

Look at the patterns below and fill in the table of values. Then complete the graph. Is the line straight?

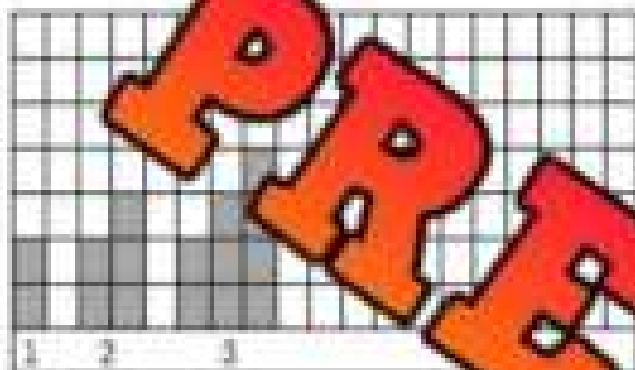

Term Number	Term Value
1	
2	
3	



1) Is this pattern linear or non-linear? Explain.

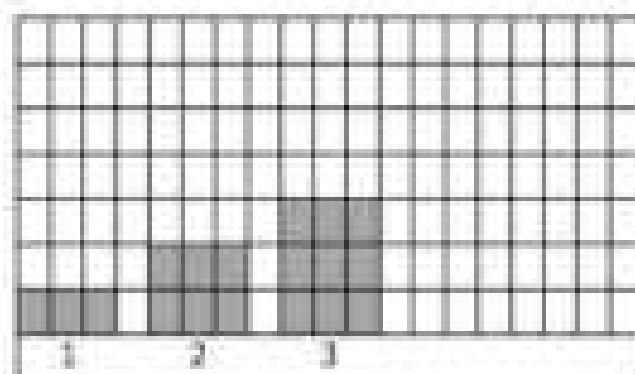

Term Number	Term Value
1	
2	
3	
4	
5	

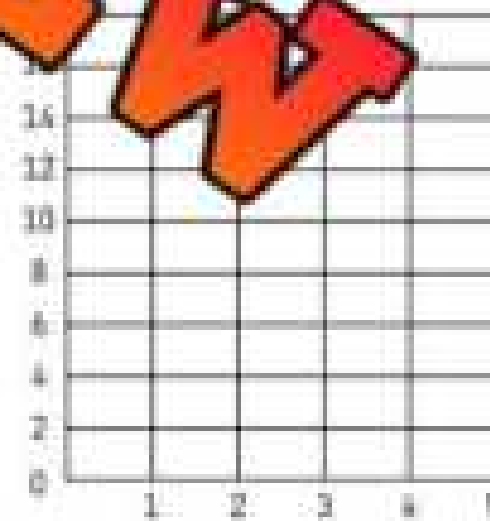

2) Is this pattern linear or non-linear? Explain.

3) How many blocks would be in term number 10?

Linear and Non-Linear Patterns

Instruction Look at the graphs closely. Answer the questions below.

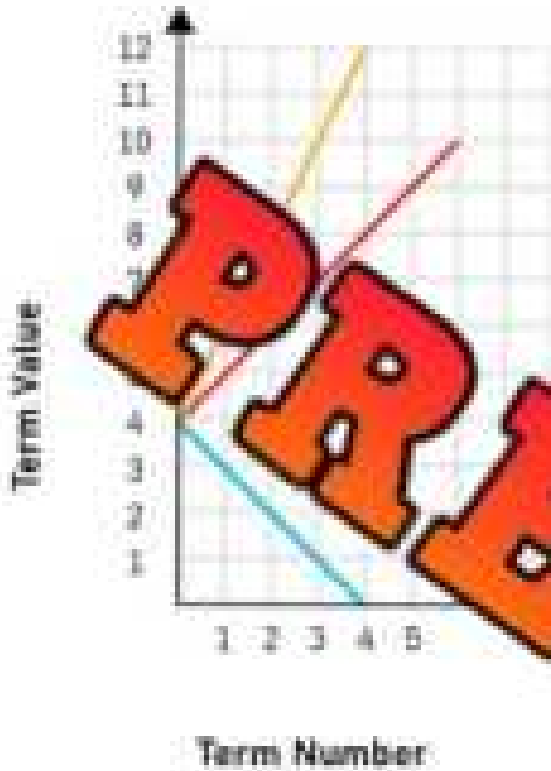

1) How are the lines the same?

2) How are the lines different?

3) What could these three lines represent?

1) How are the lines the same?

2) How are the lines different?

3) What could these three lines represent?

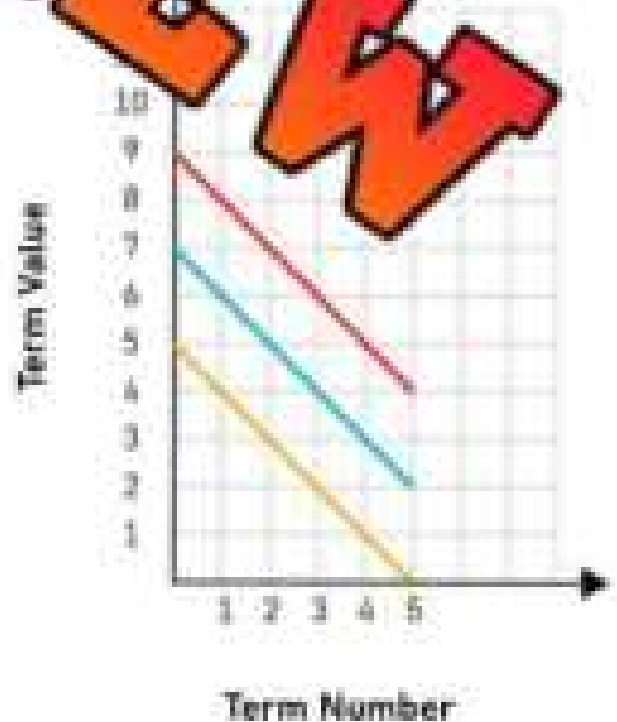

PREVIEW

Increasing Linear Patterns – Yes or No?

Instructions

Circle if the pattern displayed on the graph is linear or not.

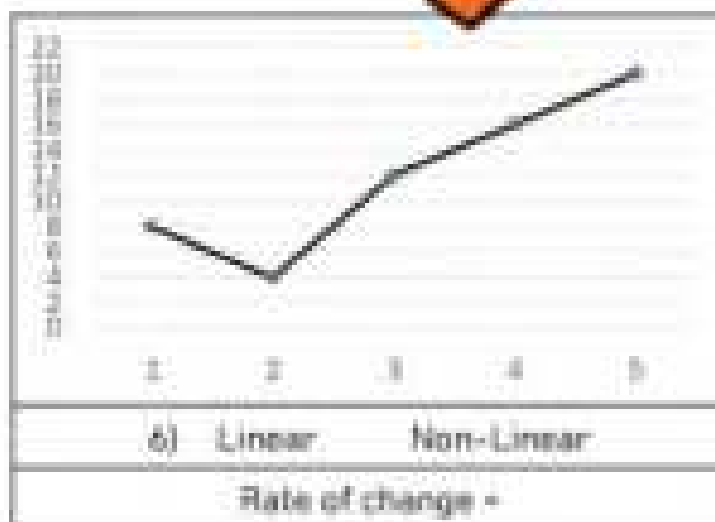
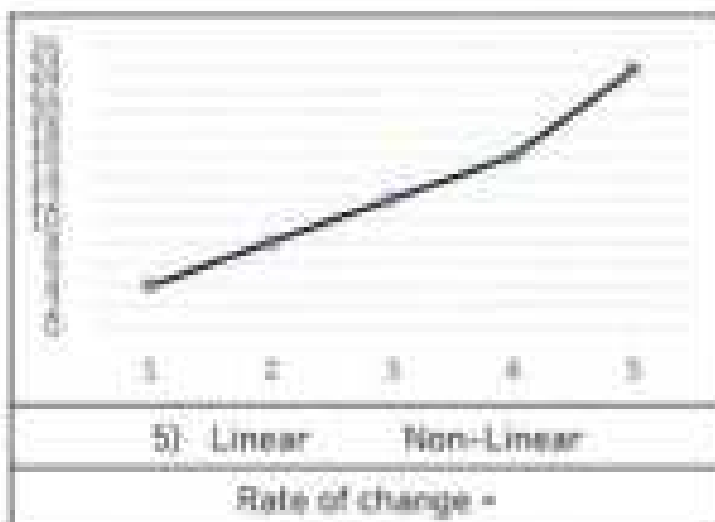
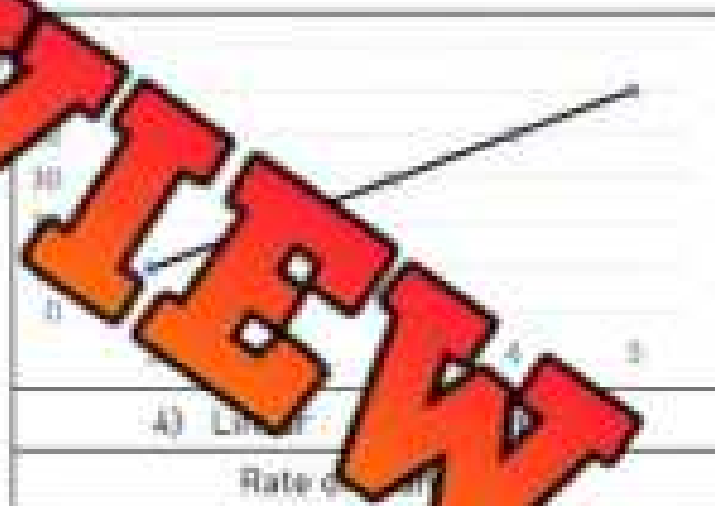
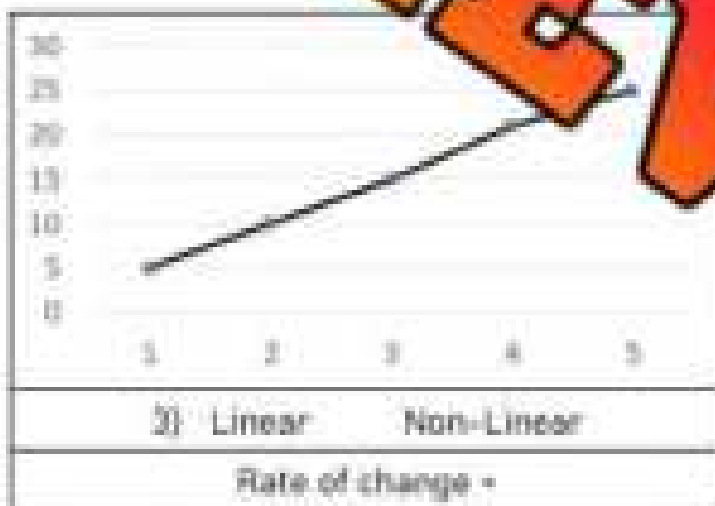
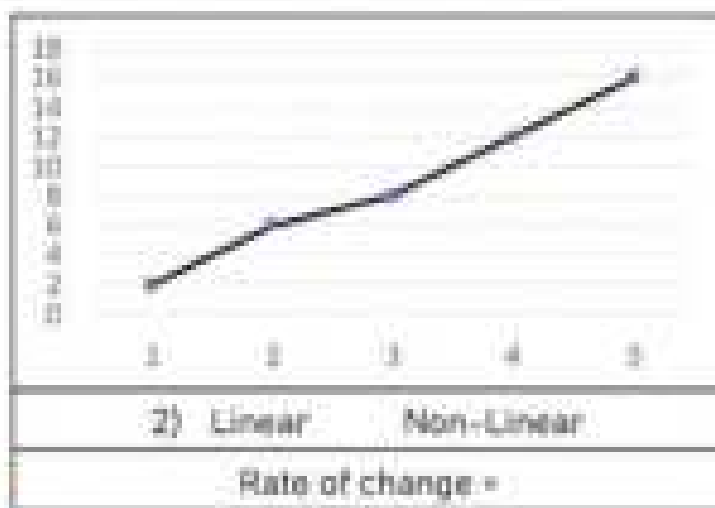
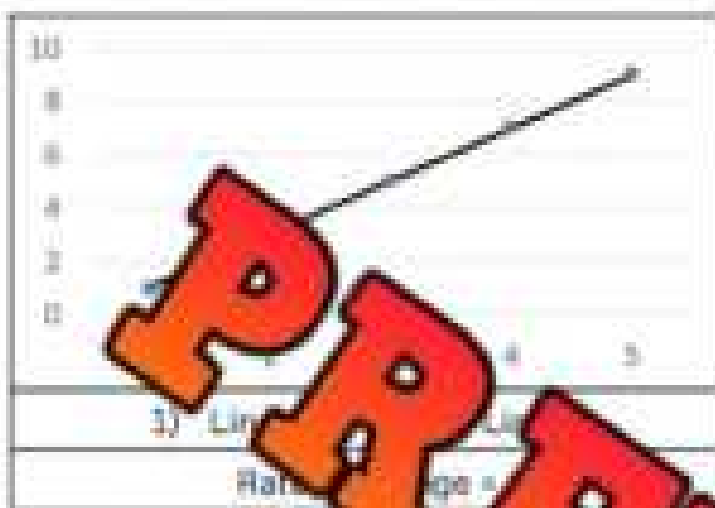

Increasing Linear Patterns – Yes or No?

Instructions

Circle if the pattern is linear or not, based on the table of values.

Term Number	Term Value
1	5
2	9
3	13
4	17
5	21
Linear	Non-Linear

Term Number	Term Value
1	37
2	44
3	51
4	57
5	64
Linear	Non-Linear

Term Number	Term Value
1	86
2	96
3	104
4	112
5	120
Linear	Non-Linear

Term Number	Term Value
1	2.5
2	4.5
3	6.5
4	8.5
5	10.5
Linear	Non-Linear

Term Number	Term Value
1	12
2	15
3	18
4	17
5	21.5
Linear	Non-Linear

Term Number	Term Value
1	200
2	275
3	350
4	425
5	500
Linear	Non-Linear

Term Number	Term Value
1	44.0
2	47.5
3	50.5
4	54.0
5	57.5
Linear	Non-Linear

Term Number	Term Value
1	140
2	280
3	420
4	560
5	720
Linear	Non-Linear

Term Number	Term Value
1	112.1
2	112.3
3	112.5
4	112.7
5	112.9
Linear	Non-Linear

Comparing Rates of Change

Questions

Circle which variable (x or y) increases at a greater rate of change.

1) Term Number	1	2	3	4	5	
x	25	45	65	85	105	
y	10	35	60	85	110	
	x	or	y			

2) Term Number	1	2	3	4	5	
x	117	123	129	135	141	
y	123	144	149	154	159	
	x	or	y			

3) Term Number	1	2	3	4	5	
x	237	243	249	255	261	
y	364	370	376	382	388	
	x	or	y			

4) Term Number	1	2	3	4	5	
x	0.5	1.2	1.9	2.6	3.3	
y	12.1	12.7	13.3	13.9	14.5	
	x	or	y			

5) Term Number	1	2	3	4	5	
x	141	150	175	192	209	
y	513	529	545	561	577	
	x	or	y			

6) Term Number	1	2	3	4	5	
x	17.8	19.9	22.0	24.1	26.2	
y	22.3	23.7	25.1	26.5	27.9	
	x	or	y			

Comparing Rates of Pay - Employees

Jeffrey is the boss at his company. He determines how much to pay his employees. Sometimes, Jeffrey pays his employees a starting bonus, where they get a one-time payment for starting their job.



Questions

Who will get paid more money over time?

Weeks	0	1	2	3	4	5	6	7
Cotton's Earnings (\$)	1000	1400	1800	2200				
Spencer's Earnings (\$)	0	500	1000	1500				

- a) Who will earn more after 7 weeks? _____
- b) How much is Cotton's earnings per week? _____
- c) How much is Spencer's earnings per week? _____
- d) Whose earnings increase at a greater rate? _____

Weeks	0	1	2	3	4	5	6	7
Jacob's Earnings (\$)	0	750	1500	2250				
Jeremy's Earnings (\$)	1500	2000	2500	3000				

- a) Who will earn more after 7 weeks? _____
- b) How much is Jacob's earnings per week? _____
- c) How much is Jeremy's earnings per week? _____
- d) If we graphed both of their earnings, whose graph would be steeper? _____

Weeks	0	1	2	3	4	5	6	7
Amelia's Earnings (\$)	2500	3350	4200	5050				
Raven's Earnings (\$)	0	1150	2300	3450				

- a) Who earned a bonus to start their job? _____
- b) How much is Amelia's earnings per week? _____
- c) How much is Raven's earnings per week? _____
- d) Who will earn more after 7 weeks? _____ How much more will they earn? _____

Writing Algebraic Expressions



Practice

Answer the question below.

1)	Situation	Expression/Answer
a)	Caleb sells lemonade at his stand. For every sale (x), he earns \$4. Write the expression.	
b)	Caleb sold 11 sales Monday. How much money did he make? Write the expression and the answer.	
c)	Caleb sold 25 cups of lemonade this week. How much money did he make? Write the expression and the answer.	
d)	Caleb earned \$40 from selling lemonade. How many cups (c) did he sell? Write the expression and the answer.	

2)	Situation	Expression/Answer
a)	Maya earns \$16 for every hour (h) she works. She also spends \$3 each time she works to take the bus home. Write the expression.	
b)	Maya worked 7 hours yesterday. How much money did she take home? Write the expression and the answer.	
c)	Maya earned \$141 today after she paid for her bus ride. How many hours did she work? Write the expression and the answer.	

3)	Situation	Expression/Answer
a)	Isaac is driving across Ontario to visit a friend. For every hour (h) he drives, he travels 115km. Write the expression.	
b)	Isaac drove 11 hours today. How far did he go? Write the expression and the answer.	
c)	Isaac needs to drive 920km. How many hours does he need to drive?	

Writing Algebraic Expressions – Growing Pattern

Questions

Draw the 4th and 5th term, then answer the questions.

				
Term 1	Term 2	Term 3	Term 4	Term 5

1) Questions	Expression
a) Write an expression that represents how many shapes are in the pattern using the variable n for term number.	
b) How many shapes will be in the 10 th term?	
c) How many shapes will be in the 20 th term?	
d) How many rectangles will be in the 10 th term?	
e) How many stars will be in the 1000 th term?	

				
Term 1	Term 2	Term 3	Term 4	Term 5

2) Questions	Expression
a) Write an expression that represents how many shapes are in the pattern using the variable n for term number.	
b) How many shapes will be in the 10 th term?	
c) How many shapes will be in the 20 th term?	
d) How many rectangles will be in the 50 th term?	

Banquet Word Problem – T-Tables

Challenge

Answer the word problem below. Use the T-Table to help.

You have been put in charge of organizing the end of the year banquet for your baseball team. You want to have as many seats as you can.

The diagram below shows how many people can sit at the tables.

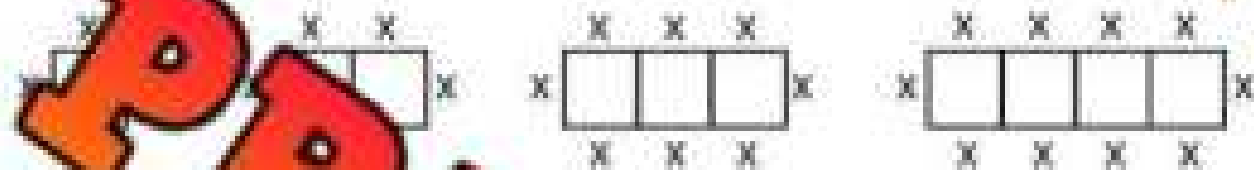

a) Fill in the table below to learn about the pattern of how many people can attend the banquet.

Tables	1	2	3	5	10	20	50
# of Seats							

b) Write the algebraic expression you used to solve for the

c) What if you didn't put the tables together? Would 8 tables fit for less than 8 tables apart? Draw a diagram to help and fill in the

Tables	1	2	3	4	5	6	20	50
# of Seats	4							

d) Write the algebraic expression you could use to solve any number of tables.

Ice Cream Sundae – Challenge Problem

Challenge

Answer the word problem below.

At Kai's Ice Cream Shop, a plain ice cream sundae costs \$3.50. Each extra topping costs \$0.75.

a) Write an algebraic expression that represents the cost of a sundae with e extra toppings.

b) Erin wants a sundae with 6 toppings. How much will it cost?

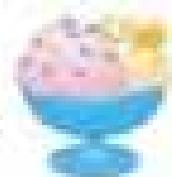

c) Levi ordered a sundae with 5 toppings. How much will it cost Levi?

d) Levi paid with a \$20 bill. How much will he have left?



e) On Thursdays, sundaes are half price! Write an algebraic expression that represents the cost of a sundae with e extra toppings.

f) Jack ordered a sundae on Thursday with 10 toppings. How much did it cost him?

g) Scarlett ordered 2 sundaes for her and a friend. Both sundaes had 6 toppings each. Write an algebraic expression that represents the cost.

Two-Variable Linear Relationship - Scientist

Challenge

Answer the word problem below.

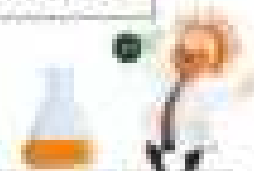

Mrs. Ferraty teaches a grade 8 class. She invited a scientist to join her class to do some experiments with them. The scientist charges \$40 for the materials they use for the experiments, plus an additional \$3 per student who is in the class.

a) Fill in the table of values below using the linear equation: $y = 3x + 40$.

Number of Students					
Cost					

b) Graph the table above.

Questions

a) Fill in the missing values in the ordered pairs below.

(25, _____), (50, _____), (100, _____)

(_____, 67), (_____, 85), (_____, 106)

b) If 28 students are in the class, how much money will the scientist earn for their presentation?

c) If the scientist earned \$136, how many students were in the class?

Two-Variable Linear Relationship - Working

Word Problems

Investigate the relationship between the two-variables.

Stephanie earns \$15 for every hour she works. She received a starting bonus of \$50 before even working an hour.



- 1) Fill in the table of values to represent the linear relationship between hours worked and money earned.

- 2) Graph the Linear Relationship.

3) Questions

- a) Write the linear equation that represents this situation.
- b) Stephanie is scheduled to work 35 hours this week. How much will she earn with her bonus?
- c) Fill in the missing values in the ordered pairs below.
- (10, _____), (42, _____), (75, _____)
- (_____, 320), (_____, 1055), (_____, 3050)
- d) Stephanie earned \$1580 in her first month of work, including her bonus. How many hours did she work?



Graphing Linear Equations - Tables

Challenge

Answer the word problem below.

You have been put in charge of organizing the end of year banquet for your baseball team. You want to have as many seats as you can.

The diagram below shows how many people can sit at the tables.

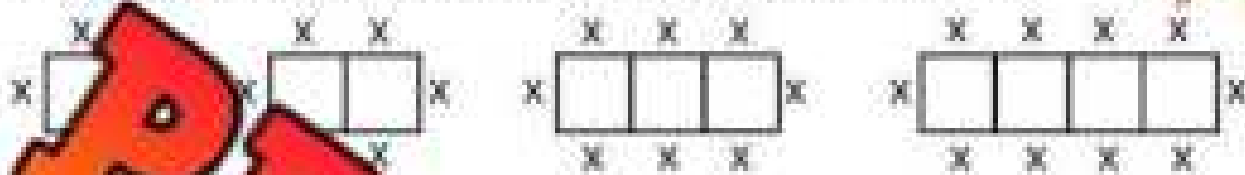

Fill in the table to represent the relationship between the number of tables and seats.

Tables (x)	4	5	10	20	50
# of Seats (y)					

Questions

- a) Write the linear equation that represents this problem.
- b) If you had 61 tables, how many seats would you have?
- c) Fill in the missing values in the ordered pairs below.
- (15, _____), (75, _____), (135, _____)
- (_____, 132), (_____, 174), (_____, 500)
- d) If you had 100 people attending the banquet, how many tables would you need?

Two-Variable Linear Relationship – Moving Day

Challenge

Answer the word problem below.



Aiden's family is moving. They rented a moving truck for \$50 a day. They are charged an additional \$0.50 for every 1km they drive.

1) Fill in the table of values below.

2) Graph the values.

3) Questions

a) Write the linear equation that represents this problem.

b) If Aiden's family drove 300km in one day, how much would they need to pay?

c) Fill in the missing values in the ordered pairs below.

(15, _____), (75, _____), (135, _____)

(_____, 130), (_____, 240), (_____, 500)

d) Aiden's family owes \$650 to the moving company. How far did they drive?

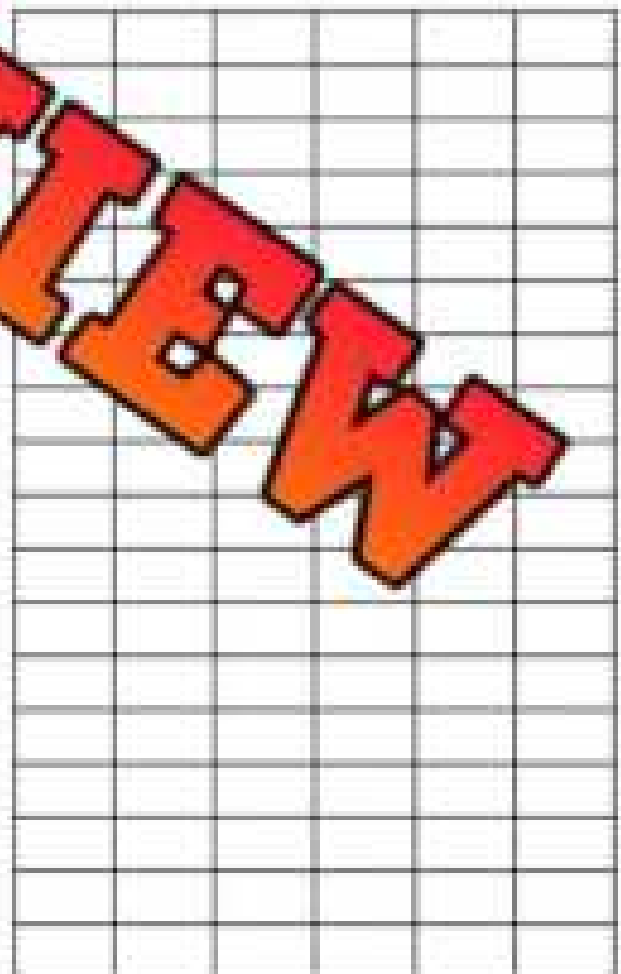

Representing Situations - Division

Part 1

Solve the expressions below using $n = 6$ and $y = 3$

	Expression	Answer
1)	$(7 + 11) \div y$	
2)	$\frac{12 + 32}{n}$	
3)	$\frac{12}{n}$	
4)	$\frac{12}{y}$	

	Expression	Answer
5)	$\frac{(n + y + 6)}{y}$	
6)	$8 + \frac{(12 + 4)}{n}$	
7)	$\frac{n}{y}$	
8)	$\frac{(11 + 4)}{y}$	

Part 2

Write an expression that represents the situation in brackets to represent the situations.

- 1) Gianna and her friends sold 12 bracelets for \$4 each. They divided the earnings up equally amongst her (f) friends.

a) Write an expression that represents the situation.

b) If Gianna worked with 2 other friends, how much would each friend get?

- 2) Zoey made 3 trays of cookies with 12 cookies on each tray. She divided up the cookies equally between (y) number of friends.

a) Write an expression that represents the situation.

b) If Zoey split the cookies with 11 friends, how much would each friend get?

- 3) Mrs. Hubert has 8 packs of pencil crayons that have 12 crayons inside each pack. She divides the pencil crayons into (g) number of groups.

a) Write an expression that represents the situation.

b) If Mrs. Hubert gave 6 crayons to each group, how many groups did she give to?



Representing Situations – Organizing a Trip

Challenge

Answer the word problem below.

Eli is organizing a trip to Canada's Wonderland. It costs him \$50 per ticket and the bus rental is \$400 for everyone to split.

a) Write an algebraic expression that represents the cost if p people go.

b) How much will the trip cost Eli if 10 people go?

c) How much will the trip cost Eli if p people go?

d) If Eli has 20 people go, how much will it cost?

e) Eli wants to offer food as well. Suppose the food costs \$10 per person. Write an algebraic expression that represents the cost for the bus and food if p people go.

f) Suppose 20 people decide to go on the trip and get food. How much will it cost Eli?

g) How much will Eli charge each person if 20 people go and get food?

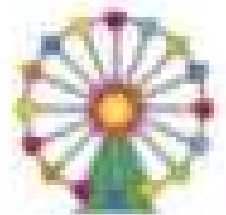

Integer Pattern – Adding Word Problem

-18	-17	-16	-15	-14	-13	-12	-11	-10	-9	-8	-7	-6	-5	-4	-3	-2	-1
-----	-----	-----	-----	-----	-----	-----	-----	-----	----	----	----	----	----	----	----	----	----

0	1	2	3	4	5	6	7	8	9	10	11	12	13	14	15	16	17	18	19	20
---	---	---	---	---	---	---	---	---	---	----	----	----	----	----	----	----	----	----	----	----

Instructions

Answer the word problem below.

Richard is playing football. He plays defense, so he is often running backwards. He decides to track his steps forwards and backwards. For every step forward, he adds $+1$ and for every step backward, he adds -1 .

- a) Each quarter, Richard takes 75 steps forwards, and -150 steps backwards. If every step forward is $+1$ and every step backward is -1 , how many steps did Richard take in the first half of the game?



- b) Fill in the table of values that records how many steps Richard takes in two games (8 quarters).

Term Number (Quarter)									
Term Value (Steps)									

- c) Write an algebraic expression to help you solve how many steps Richard took in n number of quarters.

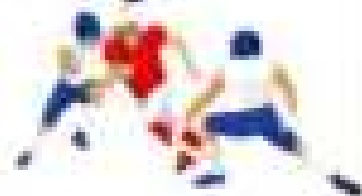

- d) In 5 games, does Richard take more steps forward or backward?
- e) How many steps does Richard take in 5 games?

Task Cards: Patterning – All Operations**Objective**

What are we learning about?

To recognize and create patterns using the four basic mathematical operations.

Materials

What will you need for the activity?

- 24 task cards
- Answer recording sheet for answers
- Timer

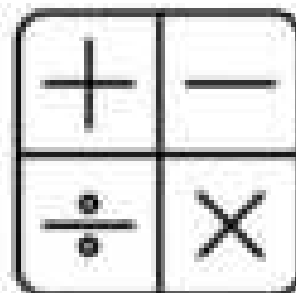
**Instructions**

What will you do for the activity?

1. Introduce the concept of patterns using the four basic operations and their relevance to problem-solving in everyday life.
2. Organize the students into pairs and provide each pair with their sets of task cards.
3. Give each pair an answer recording sheet and a timer to track their progress.
4. Encourage teamwork by having students collaborate and help each other on finding solutions.
5. Allow students to select any task card to begin with, emphasizing that they can complete the cards in any order they prefer.
6. Instruct students to record the letter of their chosen answer (A, B, or C) on their answer sheet beside the task card's number.
7. Consider using a timer to create a dynamic challenge, adjusting the duration to fit the lesson's objectives and complexity.
8. After the activity, review the answers collectively, discussing any challenging patterns and strategies used to solve them.
9. Have students reflect on the activity, sharing the methods they applied and obstacles they overcame.

Task Cards

Cut out the task cards below.

Card 1:

Start with 70. Subtract 30 and then add 10 for the next number. What is the second number?

- a) 40
- b) 50
- c) 60

Card 5:

Start at -20, add 15 each time. What is the third number?

- a) 10
- b) -5
- c) 20

Card 6:

Start with -35. Multiply by 3 and then add 20 for the next number. What is the second number?

- a) -85
- b) -105
- c) -55

Card 3:

Begin with 100. Subtract 40 and then multiply by 2 for the next number. What is the fourth number?

- a) 20
- b) 240
- c) 120

Card 7:

Start with 20. Multiply by 3 and then add 12 for the next number. What is the second number?

- a) 60
- b) 24
- c) 16

Card 4:

Start with 30. Multiply by 3 and then subtract 15 for the next number. What is the fifth number?

- a) 1260
- b) 75
- c) 1830

Card 8:

Begin with 180. Divide by 6 and then subtract 10 for the next number. What is the second number?

- a) 10
- b) 20
- c) 25

PREVIEW

Task Cards

Cut out the task cards below.

Card 17:

Start with 45. Add 25 and then subtract 30 for the next number. What is the sixth number?

- a) 40
- b) 25
- c) 20

Card 21:

Start at -25, add 20 each time. What is the seventh number?

- a) 100
- b) -35
- c) 95

Card 22:

Start with -45. Multiply by 3 and then add 25 for the next number. What is the third number?

- a) -110
- b) -220
- c) -305

Card 19:

Begin with 75. Subtract 35 and then multiply by 3 for the next number. What is the fourth number?

- a) 1875
- b) 660
- c) 255

Card 23:

Start with 100. Divide by 2 and then add 9 for the next number. What is the fourth number?

- a) 10
- b) 11
- c) 19

Card 20:

Start with 50. Multiply by 2 and then subtract 25 for the next number. What is the third number?

- a) 75
- b) 125
- c) 100

Card 24:

Begin with 170. Divide by 5 and then subtract 10 for the next number. What is the second number?

- a) 20
- b) 24
- c) 34

PREVIEW

Integer Patterns - Retirement

Instructions

Answer the questions below.

Jeremy just retired from his job. He has \$350 000 in his bank account to live off during his retirement.

a) If he withdraws -\$25 000 a year for 6 years, how much money will he have?

b) Complete the table below.

Year 1	Year 2	Year 3	Year 4	Year 5	Year 6	Year 7

c) Write an algebraic expression that shows how much money Jeremy will have left for each year (y) where y is a negative integer.

d) Jeremy has a pension that pays him +\$15 000 a year. How long could Jeremy live off his pension and \$350 000 if he continues to withdraw -\$25 000 a year?

e) Jeremy wants to buy a boat for \$120 000 and is hoping his money will last for 15 years. Can he afford the boat even with his pension? Write an equation that represents the problem.

f) Now that Jeremy owns a boat, his expenses have gone up. He now withdraws -\$35 000 each year. Can he afford his new lifestyle with his \$230 000 and pension for 15 years?



PREVIEW

Graphing Linear Equations - Exercise

Instructions

Answer the questions below.



For every 1-hour Logan exercises, he burns 250 calories. Use negative integers to fill in the table of values that tracks Logan's calorie burn.

1-Hour	2-Hours	3-Hours	4-Hours	5-Hours	6-Hours	7-Hours

a) If Logan exercises for 14 hours a week, how many calories does he burn?

b) Write the linear equation that represents the situation. Use multiplication and a negative integer.

c) If Logan has already burned 750 calories this week, how many more hours will he need to exercise to burn 2250 calories? Write an equation that represents the situation.

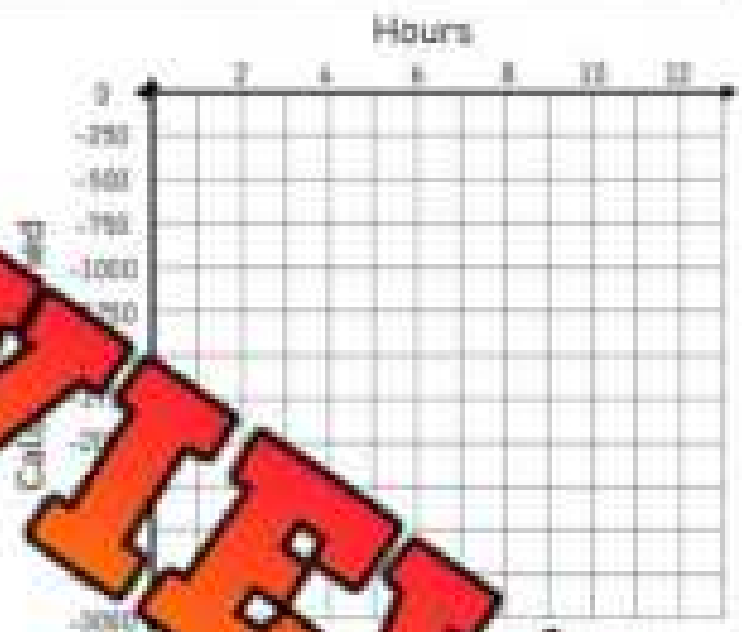

d) Describe the relationship between the two variables in your own words.

e) Fill in the missing values in the ordered pairs below

(14, _____), (20, _____), (32, _____)

(_____, -4250), (_____, -6500), (_____, -9750)

Graphing Linear Equations - Advertising

Instructions

Answer the questions below.



Chloe has an advertising budget of \$150. She decides to spend \$15 a day. Use negative integers to fill in the table of values that tracks her advertising spending. Display the table of values as a graph as well.

1) After 20 days of advertising, how much money will Chloe have left? Use a negative integer to represent the amount.

2) Write the linear equation that represents the situation. Use multiplication and a negative integer.

3) Chloe has discovered that she earns \$20 a day from people buying her products after seeing her advertisements. Use the numbers/operations below to write a new linear equation that represents the situation.

$$y = x \quad -15 \quad 20 \quad + \quad -$$

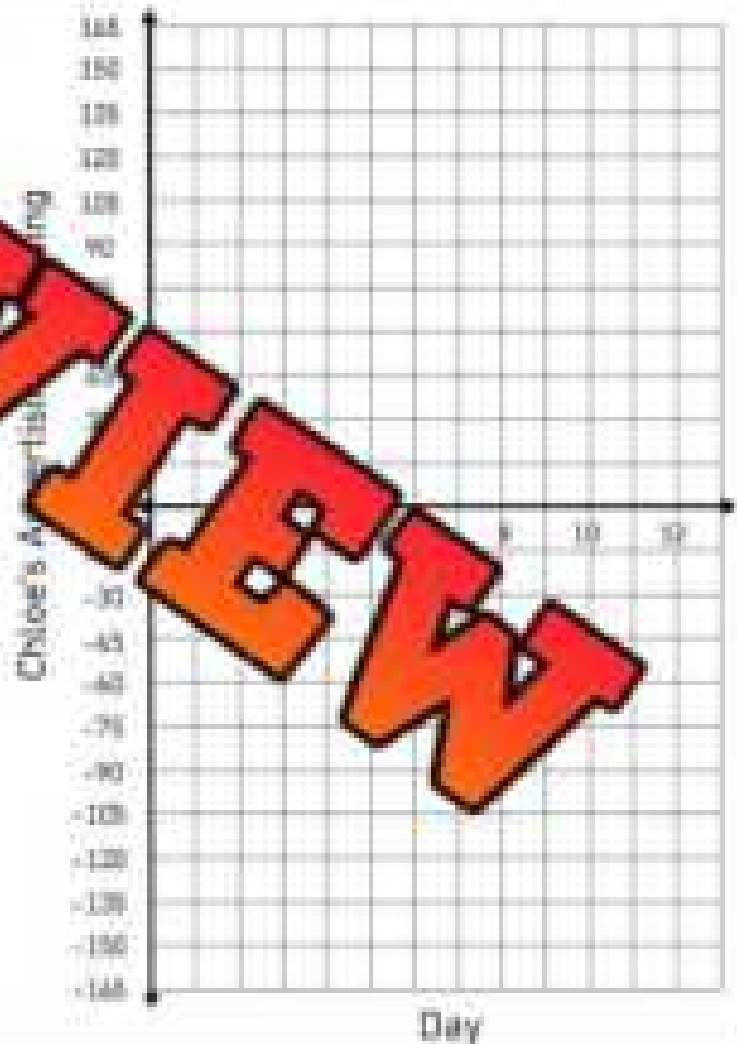

4) Matthew answered the question above using this equation: $y = x(-15) + 20$ but he isn't getting the correct answer. How could he move one bracket to get the correct answer? Why was he wrong before?

Exponential Patterns – Word Problems

Instructions

Answer the questions below.

1) Steel in 2021 costs \$2 a kg. The prices are expected to double each year for the next 10 years.

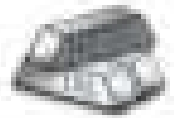

a) Fill in the table of values to represent the cost over the next 7 years.

b) Write an expression that represents the situation using an exponent and the variable y for years.

c) How much will it cost in 2028? Show your work using the expression you wrote above.

2) If one person tells 3 people a message, and each of those 3 people tell another 3 people, and so on, we have a spreading of information. This exponential growth is how things spread.



a) Fill in the table to represent how many people receive the message at each new level sends the message.

Level	1	2	3	4	5
# of People told the message					

b) Write an expression that represents how many people receive the message if it is spread to (n) levels of people.

c) In the scenario above, how many people would get the message after the message was passed to the 10th level of people?

d) What level of people would spread the message to over 1 million people?

Exponential Patterns – 1 Cent Doubled

Instructions

Answer the questions below.

1) \$10 or 1 cent doubled daily

a) Which would you rather - \$10 today or 1 cent doubled for 10 days. For example, 1 cent on day 1, 2 cents on day 2, and 4 cents on day 3.



b) How many days would it take for the doubling cents to be more than the \$10.

2) 1 million dollars or 1 cent doubled daily

a) Which would you rather - \$1 million today or 1 cent on day 1, and a doubling of the cents each day for one month (30 days). For example, 1 cent on day one, 2 on day 2, 4 cents on day 3 and so on.



b) How many days would it take for the doubling cents to be more than 1 million dollars?

3) Write an algebraic expression that represents this situation using an exponent and the variable n for the number of days.

Exponential Patterns – Power of 10

Instructions

Answer the questions below.

- 1) The Richter Scale explains how strong an earthquake is. We categorize earthquakes based on the amount of seismic energy they produce. The Richter Scale is a scale from 1 to 10, but each number represents a power of 10. For example, the Queen Charlotte Islands earthquake in British Columbia reached a magnitude of 8 on the Richter Scale. This means it produced 8×10^8 of seismic energy.

- a) An earthquake hit an island once a year for 10 years. The first year it was a 2 on the Richter Scale and the second year, it was a 3 on the Richter Scale and the third year, it was a 4 on the Richter Scale. If this pattern continues, how much seismic energy would be produced after 10 years?

- b) How much seismic energy would be produced after 10 years?



- 2) On average, the Earth is about 4.5×10^8 kilometres from Mars. A spacecraft traveled 15×10^7 kilometres per week.

- a) Fill in the table of values to represent how far the spacecraft traveled each week.

Week	1	2	3	4	5
Distance (km)					

- b) How many weeks did it take the spacecraft to reach Mars?

- c) How many km did the spacecraft travel to get to Mars and back to Earth?



Algebra Quiz - Patterning

Part 1

Label the A/B patterns below and then extend the pattern.

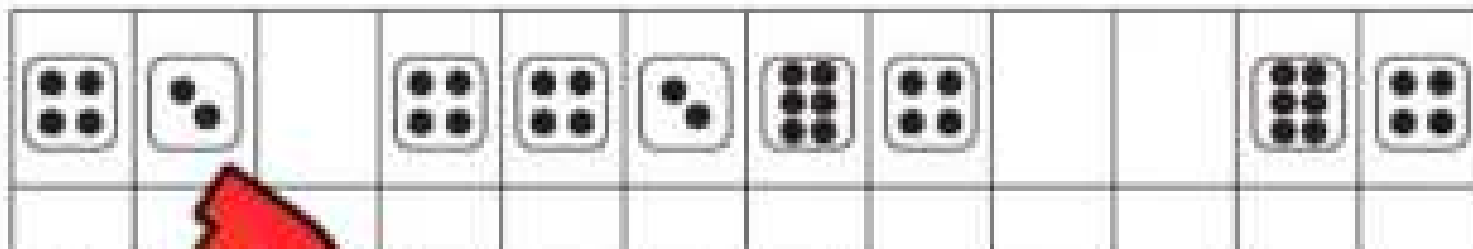

1) What is the pattern in the pattern be?

2) What is the 5th term in the pattern be?

Part 2

Find the pattern rule for each term? Sketch the next 3 terms.



Describe the Pattern Rule

Figure #	1	2	3	4	5	6
# of Matchsticks						

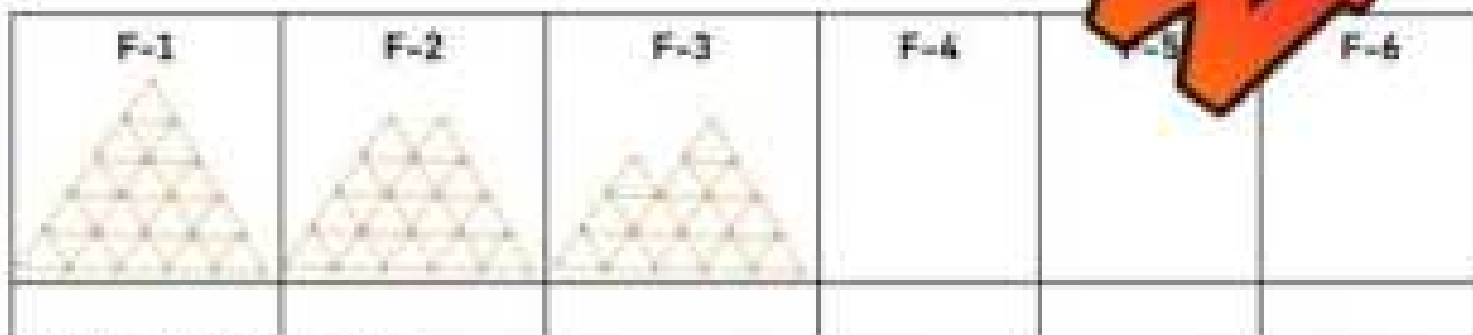

What is the Pattern Rule?

Figure Number	1	2	3	4	5
Number of Matchsticks					
How many matchsticks would be in term 10?					

Part 3

Fill in the tables below to show a constant rate of change.

1) Cole's pay for today has been represented in the table below

Hours Worked	0	1	2	3	4	5	6	7	8
Money Earned (\$)	0	27	54	81					

What is the rate of change? _____ Is the rate of change constant? Yes No

2) It costs \$21 for admission to an amusement park. Once inside, you pay for each additional ride that you go on.

Rides	0	1	2	3	4	5
Total Cost (\$)		\$31.50	\$33.00	\$34.50	\$36.00	\$37.50

a) Write a verbal rule for the table. It costs _____ to enter the park and go on rides.

b) Write an algebraic expression that represents the rule for riding n number of rides.c) How much would it cost to ride n rides?

Part 4

Fill in the input/output tables below.

In n	Out $n + 15$
135	
142	
163	
178	

In n	Out $n + 1$
3	
5	
8	
11	

In n	Out $n - 11$
45	
488	

In n	Out $3n + 6$
1	
2	
3	
4	
5	

In n	Out $4n + (-6)$
5	
10	
15	
20	
25	

In n	Out $n - (-7)$
-1	
-2	
-3	
-4	
-5	

Part 5

Answer the word problem below.

Nathan drives a car that burns 10 litres of gas every 100km.

- a) Use negative integers in the table of values to represent how much gas he uses compared to how far he drives.

Distance (km)							
Fuel (L)							

- b) If he drives 200km, how many litres of gas would he need?
- c) Write an algebraic expression that represents how many litres of gas he needs compared to how far he drives. Use a negative integer.

- d) If Nathan drives 550km, how many litres of gas would he need?

- e) Display the data in the graph by using a line graph.

- f) Is the pattern a linear pattern?
Explain.

- g) How many km would he drive to burn 5,000 litres of gas? Show your work by using the expression from above.

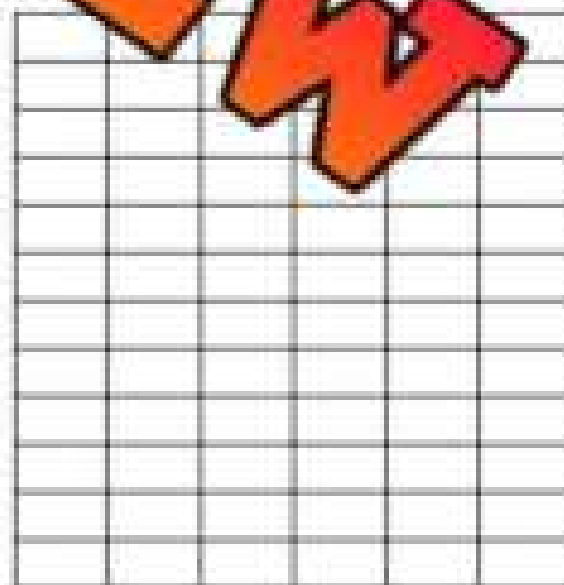

Fuel Consumer (L)



Distance

Part 6

Draw the 4th and 5th term. Then answer the questions.

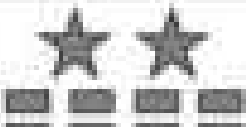
				
Term 1	Term 2	Term 3	Term 4	Term 5
Question			Expression	
a) Write an expression using the variable t for term number that represents the number of shapes in the pattern?				
b) How many shapes will be in Term 4?				
c) How many shapes will be in Term 5?				
d) How many rectangles will be in Term 10?				
e) How many stars will be in the 100 th term?				

Part 7

Answer the word problem below.

Admission to an arcade is \$5. Each game you play will cost 1 token. Each token costs \$1.

- a) Fill in the table of values to represent the cost of going to the arcade and playing n number of games.

- b) Write an expression that represents how much it will cost you to enter the arcade and play n number of games.
- c) Albert plays 25 games at the arcade. How much did he have to spend?
- d) What is the pattern rule?

Grade 8

C2. Equations and Inequalities

	Curriculum Expectations	Pages That Cover the Expectations
C2.1	add and subtract monomials with a degree of 1, and add binomials with a degree of 1 that involve integers, using tools	66 - 101
C2.2	evaluate algebraic expressions that involve rational numbers	102 - 113
C2.3	solve equations that involve multiple terms, integers, and decimal numbers in various contexts, and verify solutions	114 - 152
C2.4	solve inequalities that involve integers, and verify and graph the solutions	153 - 184

What is a Monomial?

A **monomial** is an algebraic expression that has only one term. A **term** is a single mathematical expression. It could be a single number, a single variable, or several variables multiplied together. A term is not numbers or variables added or subtracted.

For example, $2y$ is a monomial because it is just one term. $2y - 3$ is not a monomial because it has two terms: $2y$ and 3 . On the other hand, $2yx$ is one term because the numbers and variables are multiplied, not added or subtracted. This means $2yx$ is a monomial. An expression with 2 terms, it is called a binomial.

Part 1 How many terms does the expression have? Is it a monomial or binomial?

	Expression	# of Terms	Monomial or Binomial
1	$2x + 3y$		
2	$3x + 2y$		
3	$2x - 3y$		
4	$12xy$		
5	$3(2x)$		
6	$15(9yx)$		
7	$(2x) + (15y)$		
8	$3(5x) - 2(5y)$		
9	$4(5x + 6)$		
10	$14(3x) - 2(2x)$		

Part 2 Write your own monomials and binomials using 8 , y , x , 6

	Monomial or Binomial	# of Terms	Expression
1	Monomial		
2	Monomial		
3	Binomial		
4	Binomial		
5	Binomial		

What is a Monomial?

Part 1

Add the monomials together.



1) $8n + 3n$

= _____ n

2) $11p + 4p$

= _____ p

3) $12t + 14t$

= _____ t

4) $13b + 3b$

= _____ b

5) $24n + 44n$

= _____ n

6) $34p + 32p$

= _____ p

7) $5y + 13y$

= _____ y

8) $13n + 28n + 21n$

= _____ n

9) $24x + 39x + 32x$

= _____ x

Part 2

Add the monomials together.

1) $7n + 2c + 6c + 8n$

= _____ n = _____ c

2) $5r + 9s$

= _____ s

3) $12n + 19p + 27p$

= _____ n = _____ p

4) $19n + 21c + 14c + 11n$

= _____ n = _____ c

5) $19s + 24r + 33s$

= _____ s = _____ r

6) $23s + 17r + 12s + 24r$

= _____ s = _____ r

Exit Cards

Cut Out Cut out the exit cards below and have students complete them at the end of class.

Name: _____

Add the monomials together

1) _____	2) $11q + 7q$ = _____
3) _____	_____
4) $9g + 2k + 3g$ = _____	_____

Name: _____

Add the monomials together

1) $9s + 3s$ = _____	2) $11q + 7q$ = _____
3) $8f + 5c + 7c + 2f$ = _____	
4) $9g + 2k + 3g + 8k$ = _____	

Name: _____

Add the monomials together

1) $9s + 3s$ = _____	2) $11q + 7q$ = _____
3) $8f + 5c + 7c + 2f$ = _____	
4) $9g + 2k + 3g + 8k$ = _____	

Name: _____

Add the monomials together

1) $9s + 3s$ = _____	2) $11q + 7q$ = _____
3) $8f + 5c + 7c + 2f$ = _____	
4) $9g + 2k + 3g + 8k$ = _____	

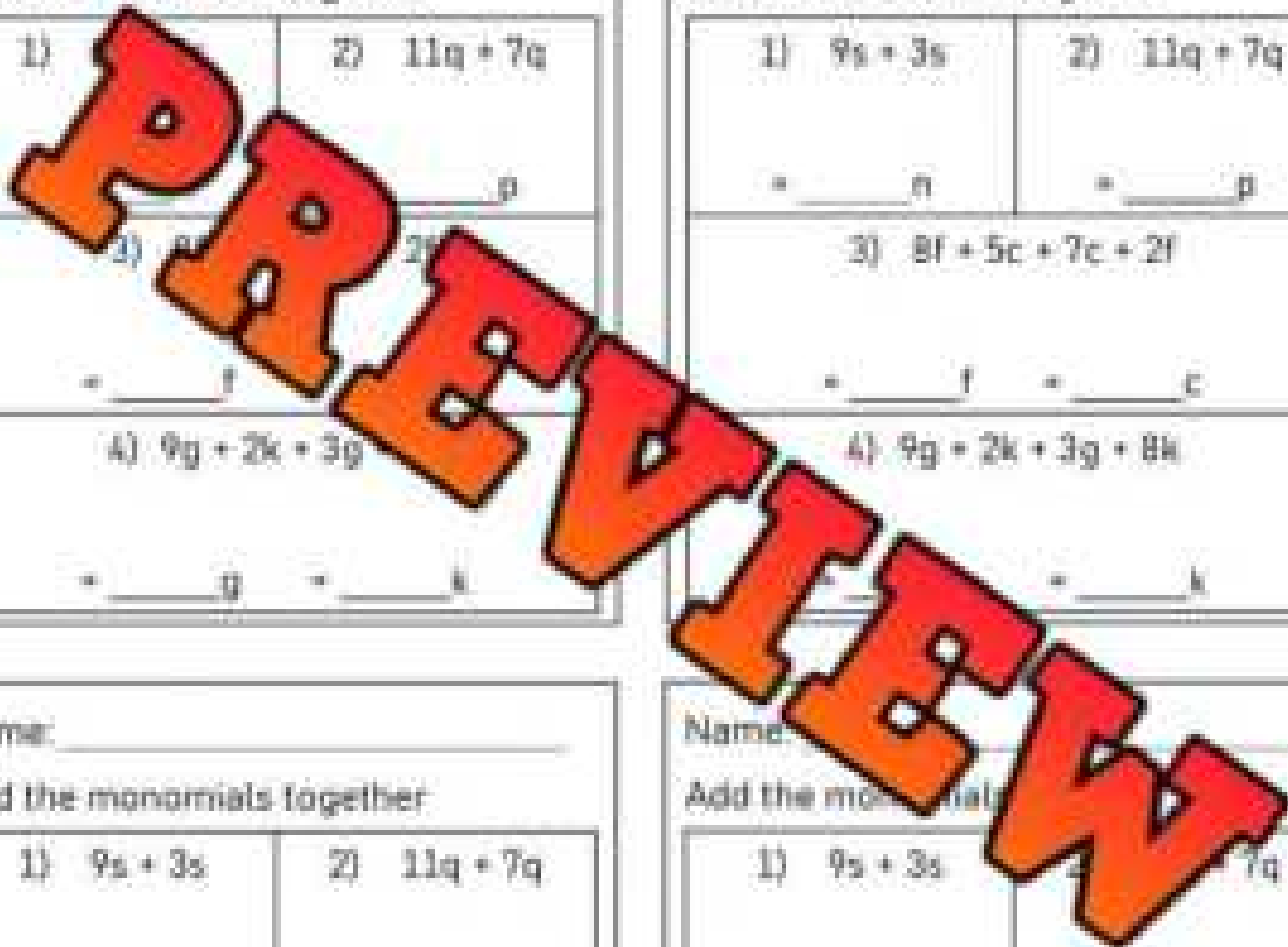

Simplifying Expressions - Adding Monomials

Questions

Simplify the expressions by solving one step at a time.



1) $3m + 9m + (7y + 10y)$
 $3m + 9m + 17y$
 $12m + 17y$

2) $22s + 3r + 11r + 6s$

$16n + 7n + 36p$

$16n + 31n + 18c + 27c$

$35s + 12s + 24r + 13r$

5) $35s + 12s + 24r + 13r + 11r + 19r + 6r + m$

$14y + 19n + 15c + 11c + 25n + 4y$

8) $29n + 34y + 10c + 28n$

$c + 54y + 49b + 52b + 73y + c$

10) $73n + 41c + 67c + 24n + 1y + 18y$

$_____y \quad + \quad _____b \quad + \quad _____c$

$_____n \quad + \quad _____c \quad + \quad _____y$

Adding Monomials – Missing Addend

Part 1

What is the value of the missing addend?

1)	$3y + \boxed{6y} = 9y$
2)	$11m + \boxed{} = 19m$
3)	$ + \boxed{} = 27t$
4)	$17b + \boxed{} = 34b$
5)	$ - 2y = $
6)	$15r + \boxed{} = $
7)	$\boxed{} + 36y = 57y$
8)	$46y + \boxed{} = 52y$
9)	$\boxed{} + 22y = 57y$
10)	$51b + \boxed{} = 77b$

11)	$29y + 13y + \boxed{} = 56y$
12)	$\boxed{} + 22t + 36t = 79t$
13)	$33y + 16y + \boxed{} = 72y$
14)	$\boxed{} + 21t + 46t = 89t$
15)	$36y + 23y + \boxed{} = 87y$
16)	$\boxed{} + 27t + 42t = 77t$
17)	$\boxed{} + 57t + 66t = 109t$
18)	$64y + + \boxed{} = 135y$
19)	$ + 54t + = 149t$
20)	$64y - 73y = $

Part 2

Write an addition equation using the monomials provided.

1)	27y	71y	64y
3)	31b	35b	4b
5)	84y	27y	57y

2)	36n	24n	12n
4)	79c	108c	29c
6)	61n	34n	95n

Subtracting Monomials - Tiles

Questions

Subtract the monomials by crossing out the tiles you've subtracted.

1) $10n - 3n - 2n$

n	n	n	n	n
n	n	n	n	n

2) $12p - 6p - 2p$

p	p	p	p	p	p
p	p	p	p	p	p

= _____ p

3) $17s - 5s$

s	s	s	s	s	s	s	s	s	s
s	s	s	s	s	s	s	s	s	s

4) $18c - 12c - 3c$

c	c	c	c	c	c	c	c	c	c
c	c	c	c	c	c	c	c	c	c

= _____ s

= _____ c

5) $17b - 9b - 3b$

b	b	b	b	b	b	b	b	b	b
b	b	b	b	b	b	b	b	b	b

6) $22y - 11y - 5y$

y	y	y	y	y	y	y	y	y	y
y	y	y	y	y	y	y	y	y	y

= _____ b

7) $25c - 8c - 13c$

c	c	c	c	c	c	c	c	c	c	c	c	c	c	c
c	c	c	c	c	c	c	c	c	c	c	c	c	c	c

8) $26n$

n	n	n	n	n	n	n	n	n	n	n	n	n	n	n
n	n	n	n	n	n	n	n	n	n	n	n	n	n	n

= _____ c

= _____ n

9) $30r - 11r - 15r$

r	r	r	r	r	r	r	r	r	r	r	r	r	r	r	r	r	r
r	r	r	r	r	r	r	r	r	r	r	r	r	r	r	r	r	r

10) $29n - 16n - 11n$

n	n	n	n	n	n	n	n	n	n	n	n	n	n	n	n	n	n
n	n	n	n	n	n	n	n	n	n	n	n	n	n	n	n	n	n

= _____ r

= _____ n

Subtracting Monomials

Part 1

Subtract the monomials.

1) $7n - 2n$ = _____ n	2) $9p - 4p$ = _____ p	3) $15t - 10t$ = _____ t
4) $9b$	5) $28n - 14n$ = _____ n	6) $34p - 19p$ = _____ p
7) $65y - 24y$ = _____ y	8) $52n - 34n - n - 11n$ = _____ n	9) $57y - 12y - 7y - 9y$ = _____ y
10) $33n - 11n - 11n - 9n$ = _____ n	11) $14y$	12) $94a - 25a - 21a - a$ = _____ a

Part 2

What is the value of the missing coefficient?

1) $15y - \boxed{6y} = 9y$	8) $15t - \boxed{11t} = 4t$
2) $18m - \boxed{} = 1m$	9) $\boxed{} - 7t = 18t$
3) $25t - \boxed{} = 17t$	10) $58y - 14y - \boxed{} = 17y$
4) $39b - \boxed{} = 24b$	11) $\boxed{} - 13t - 26t = 29t$
5) $\boxed{} - 22y = 31y$	12) $76y - 13y - \boxed{} = 41y$
6) $45r - \boxed{} = 23r$	13) $\boxed{} - 21t - 32t = 46t$
7) $\boxed{} - 31y = 19y$	14) $\boxed{} - 68t - 56t = 49t$

Adding and Subtracting Monomials

Follow these steps to simplify the expressions below

- 1) Identify like terms (terms with the same variable)
- 2) Rearrange terms so that the like terms are together
- 3) Combine like terms

$$\begin{aligned} 6m + 8y - 3m - y \\ 6m - 3m + 8y - 1y \\ 3m + 7y \end{aligned}$$

Questions

Simplify the expressions by solving one step at a time.

1) $2m - 11m$	2) $12n + 14n - 17n + n$
= _____	= _____
3) $15s - 3r$	4) $2n - c + 13n - 21c$
= _____ s = _____ r	= _____ n = _____ c
5) $13s + 12r - 14s - 13r$	6) $2r + 6r$
= _____ s = _____ r	= _____ s
7) $15m + 7y - 3m - 3y$	8) $23n - 18p - 17n - 15p$
= _____ m = _____ y	= _____ n = _____ p
9) $18s - 33r + 15r - 22s$	10) $22n - 53c - 33n + 21c$
= _____ s = _____ r	= _____ n = _____ c

Distributive Property - Addition

The distributive property is used to make difficult problems simpler. It means that when we multiply a number by the sum of two or more addends, we get the same result as multiplying each addend separately by the number.

You can use the distributive property of multiplication to rewrite expressions that have a number outside of a parenthesis.

Example 1

7(5 + 3)

7 × 5

7	5	+ 3
7	35	21

Example 2

4(y + 8)

4 × y + 4 × 8

4y + 32

4	y	+ 8
4	4y	32

Evaluate

Fill in the boxes to represent the distributive property of the expressions.

1) $9(4 + 6)$

2) $6(3 + n)$

3) $8(7 + 3)$

4) $7(n)$

5) $8(f + 11)$

6) $-3(5 + p)$

Expand

Evaluate the expressions below

1) $9(t + 7)$

2) $-2(8 + 12)$

3) $-6(s + 3)$

4) $8(y + 4)$

5) $5(-11 + n)$

6) $-4(-12 + k)$

Distributive Property – Equivalent Expressions

Match

Write the letter from column 2 beside the equivalent expression from column 1.

1

Answer	Column 1	Letter	Column 2
	$3(9 - 5)$	a	$15 + 27$
	$-3(9 + 5)$	b	$(-15) + 27$
	$3(5 + 9)$	c	$3 \times 9 - 3 \times 5$
	$-3(5 - 9)$	d	$(-27) + (-15)$

2

Answer	Column 1	Letter	Column 2
	$-7(t + 9)$	a	$-63 - 7t$
	$-7(t - 9)$	b	$7t + 63$
	$7(t + 9)$	c	$-7t + 63$
	$-7(t - 9)$	d	$63 - 7t$

3

Answer	Column 1	Letter	Column 2
	$8(11 - n)$	a	$-88 + 8n$
	$-8(n + 11)$	b	$88 + 8n$
	$8(11 + n)$	c	$-88 + 8n$
	$-8(11 - n)$	d	$88 + 8n$

4

Answer	Column 1	Letter	Column 2
	$3(y - 5)$	a	$3y + 15$
	$-3(y + 5)$	b	$-3y + 15$
	$3(y + 5)$	c	$3y - 15$
	$-3(y - 5)$	d	$-3y - 15$

Mixed Operations - BEDMAS

When solving an equation, you need to follow the order of operations. This means you have to solve the equation in the correct order, not just from left to right. Using BEDMAS helps us remember the order to solve.

1. Brackets 2. Exponents 3. Division or Multiplication (whichever is first) 4. Addition or Subtraction (whichever is first)

Example 1

$$2 + (4 \times 5) = n$$

$$2 + 20 = n$$

$$n = 22$$

Example 2

$$n - (2 \times 3) = 4$$

$$n - 6 = 4$$

$$n = 10$$

Example 3

$$8 - (4n) = 20$$

$$8 - 7 \times 4 = 20$$

$$n = 7$$

Part 1

Which operation do you do first?

1) $3 + (4 \times 5) = n$

2) $21 - 7 + 4 = t$

3) $(8 \times 4) + (4 - 2) = t$

4) $n + (12 \div 6) = 12$

5) $12 \div (2 + 1) = 4$

6) $2 = 8$

Part 2

Alex and Avery both answered the questions below. Circle who's right.

	Question	Alex's Answer	Avery's Answer
1	$2 + 6 \times 4 + 12$	44	38
2	$10 - 2 \times 3$	4	24
3	$9 - 3 \times (2 + 1)$	0	18
4	$5 \times 3 + 8 = 2$	19	11
5	$12 \div 3 \times (5 + 5)$	25	40

Writing Algebraic Expressions

Using algebraic expressions helps us understand mathematical situations. We can use a variable to replace a changing number, like how many tickets are sold to a game - $t \times 10$

Part 1

Write each algebraic expression in words.
Use the words, "a number" in place of the variable.

1) $9 - t$

Nine subtract _____

2) n

3) $b + b$

4) $12r$

5) $\frac{z}{8} + 5$

6) $9 - t + 21$

7) $\frac{23}{7} + 13$

8) $(8b) - (4x)$

9) _____

10) _____

Part 2

Write an algebraic expression for each statement.

1) Twelve times a number subtract eight

2) Divide a number by seven and multiply it by a different number

3) A number is subtracted by fourteen divided by five

4) Triple a number subtracted by double a different number

5) Divide eighty by a number, then multiply by four

Finger Signals Quiz - Understanding Algebraic Expressions**Objective**

What are we learning about?

Students will reinforce their understanding of algebraic expressions through an interactive finger signals quiz.

Materials

What do you need for the activity?

- A list of questions

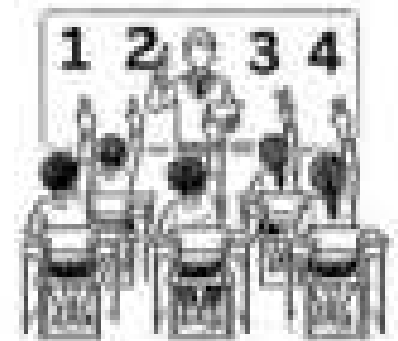
**Instructions**

How do you complete the activity?

1. Prepare a list of questions with answers labeled A, B, C, and D.
2. Explain the finger signals for each answer choice: one finger for A, two fingers for B, three fingers for C, and four fingers for D.
3. Inform the students they will show their answer by raising the appropriate number of fingers when you read each question.
4. Read the first question aloud clearly and repeat if necessary.
5. Give students a few moments to think about their answer and decide independently.
6. After a countdown (e.g., "3, 2, 1"), have all students show their answer simultaneously by raising the appropriate number of fingers.
7. Reveal the correct answer and explain why it is correct.
8. Repeat with different questions to reinforce understanding of algebraic expressions.

Question	A	B	C	D
A student reads r pages each day for 5 days. What is the total number of pages read?	$5 + r$	$5 \times r$	$5r$	$r \times 5$
A photographer takes p photos, takes 4 more each day for 5 days, and then deletes 8. How many photos are there now?	$p + (4 \times 5)$	$(p + 24) - 8$	$p + 24$	$p + (4 \times 5) - 8$
A farmer has f cows, buys 18 more, and sells 7. How many cows are there now?	$f + 18 - 7$	$f + 18 + 7$	$f + 18 + 7$	$f + 18 - 7$
A librarian shelves 40 books over the course of h hours. What is the average number of books shelved per hour?	$40 + h$	$40 - h$	$40h$	$40 \div h$
A farmer has f rows of trees and has 6 trees in each row. How many trees are there?	$6 + f$	$6 \times f$	f	$f \times 6$
A worker earns w dollars per hour for 7 hours. What is the total amount earned?	$7 + w$	$7 \times w$	$7w$	$w + 7$
A library has b books, receives 50 more, and loses 20. How many books are there now?	$b + 50 - 20$	$b + 50 + 20$	$b + 50 + 20$	$b + 50 - 20$
A factory produces p products each day for 10 days. What is the total production?	$10 + p$	$10 \times p$	$10p$	$p + 10$
A librarian has b books, receives 7 more each hour for 8 hours, and then donates 10. How many books are there now?	$b + (7 \times 8) - 10$	$b + (7 + 8)$	$b + (7 \times 8)$	$b + 7 \times 8 - 10$
A runner runs 40 kilometres over the course of d days.	$40 + d$	$40 \times d$	$40d$	$40 \div d$
A school has s students but loses 20. What is the total number of students?	$s + 20$	$s - 20$	s	$s - 20$
A gardener has g plants, plants 5 more each day for 3 days, and then removes 4. How many plants are there now?	$(g + 15) - 4$	$g + 15 + 4$	$g + 15$	$(g + 15) + 4$
A chef cooked 120 meals over the course of m days. What is the average number of meals cooked per day?	$120 + m$	$120 - m$	$120m$	$120 \div m$
A baker makes b batches of cookies each day for 4 days. What is the total number of batches?	$4 + b$	$4 \times b$	$4b$	$b + 4$
Sarah has s apples and buys 5 more. How many apples does she have now?	$s + 5$	$s - 5$	$5s$	$s + 5$
A store has k kites but sells 30. What is the total number of kites left?	$k + 30$	$k - 30$	$30k$	$k - 30$
An artist has a paintings, paints 2 more each day for 5 days, and then sells 6. How many paintings are there now?	$a + (2 \times 5)$	$(a + 10) + 6$	$a + (2 \times 5)$	$a + (2 \times 5) - 6$

Evaluating Algebraic Expressions - Addition**Part 1**Evaluate the following expressions for $x = -7$

1) $x + 13$	2) $9 + x$	3) $25 + x$	4) $x + 17$
5) $39 + x$	6) $83 + x$	7) $74 + x + 11$	8) $87 + x + 24$

Part 2Evaluate the following expressions for $y = -7$ and $n = 4$

1) $n + y$	2) $1 + y + n$	3) $12 + y + n$	4) $y + 18 + n$
5) $54 + y + n$	6) $n + (y + 20)$	7) $25 + n + (y + 4)$	

Part 3Evaluate the following expressions for $x = -5$ and $p = -1$

1) $(x) + (p) - 23$	2) $17 + x + (p)$	3) $(19 + x) + (p)$	4) $x + (35 + p)$
5) $(p + 27) + x$	6) $x + 49 + (p)$	7) $(x + 63) + (p)$	8) $88 + p + x$

Exit Cards

Cut Out Cut out the exit cards below and have students complete them at the end of class.

Name: _____

Evaluate the following expressions for $x = -12$ and $p = -12$.

1) $(19 + x) + (p)$

2) $x + (35 + p)$

3) $(x) + (p) - 23$

Name: _____

Evaluate the following expressions for $x = -5$ and $p = -12$.

1) $(19 + x) + (p)$

2) $x + (35 + p)$

3) $(x) + (p) - 23$

Name: _____

Evaluate the following expressions for $x = -5$ and $p = -12$.

1) $(19 + x) + (p)$

2) $x + (35 + p)$

3) $(x) + (p) - 23$

Name: _____

Evaluate the following expressions for $x = -5$ and $p = -12$.

1) $(19 + x) + (p)$

2) $x + (35 + p)$

3) $(x) + (p) - 23$

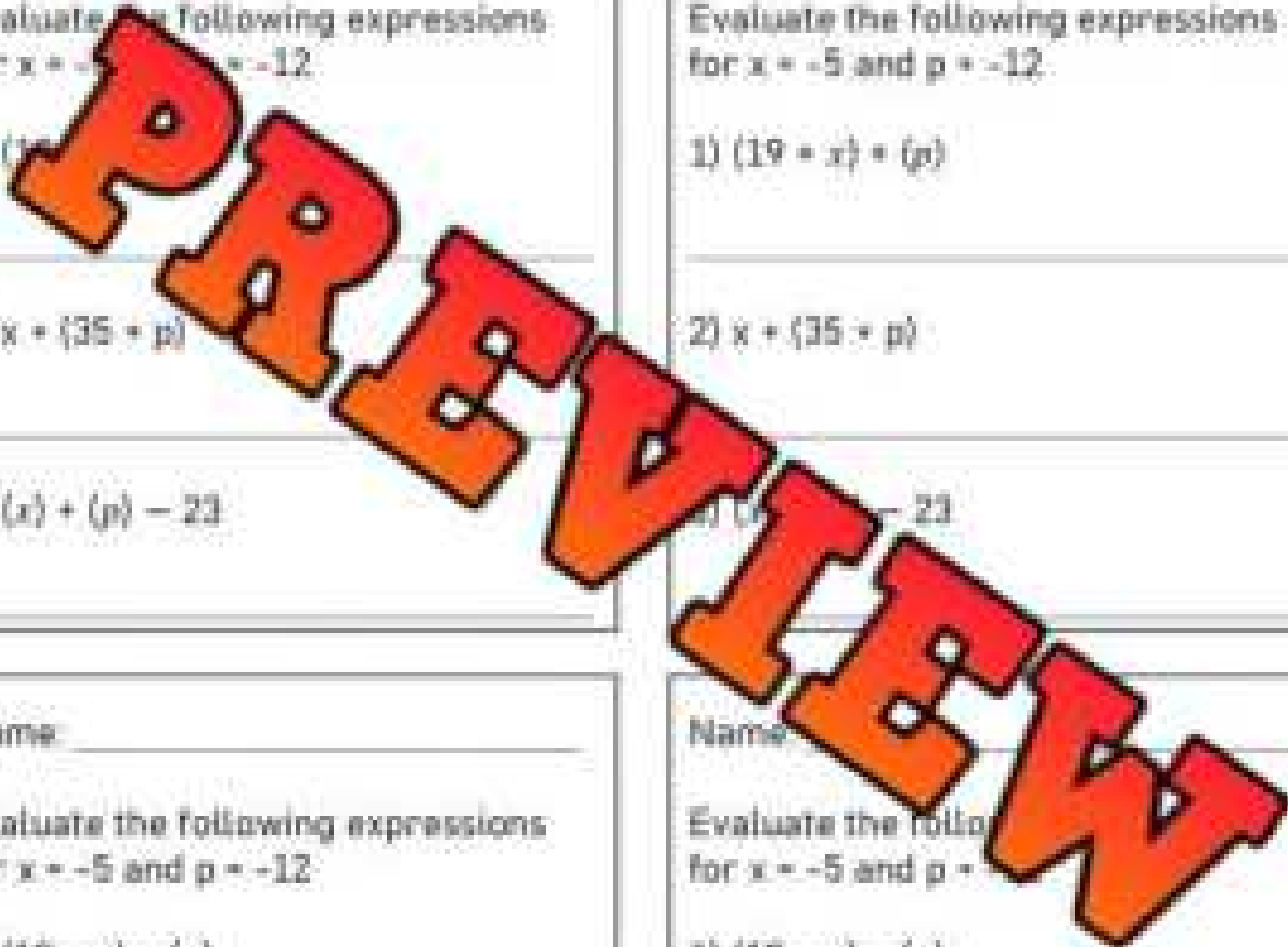

Evaluating Algebraic Expressions - Subtraction

Subtraction Integers Rules

To subtract integers, it is easiest to change the operation to addition and then follow the addition rules. We can do this by using the rule - Keep, Flip, Change. We keep the first number the same, flip the operation from subtraction to addition, and then change the third number's sign.

Example: $5 - (-6) = 7$ becomes $5 + 6 = 11$

Keep the
first
integer

Flip the
operation

Change the
sign of the next
integer

Part 1 Evaluate the following expressions for $x = -8$

1) $x - 15$	2) $27 - x$	3) $x - 31$
5) $47 - x$	6) $61 - x$	7) $94 - x - 14$

Part 2 Evaluate the following expressions for $y = -12$ and $n = -5$

1) $y - n$	2) $(16 - n) - y$	3) $15 - (y - n)$	4) $y - 11 - n$
5) $21 - y - n$	6) $(n - y) - 36$	7) $y - (n + 43)$	8) $(28 - n) - y$

Evaluating Expressions – Food Truck

Walker works at a food truck selling burgers, hot dogs, fries, and pogos. He uses algebraic expressions to determine the cost of his customer's orders.

Menu	
Burger (b)	\$4.50
Hot Dog (h)	\$2.75
Fries (f)	\$3.25
Pogo (p)	\$1.50

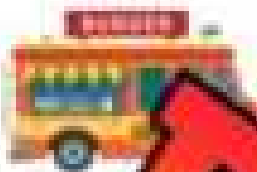

Solve each problem. Write an algebraic expression and then evaluate using the menu prices.

Customer Order	Expression	Answer
1) 2 burgers, 1 fry	$2 \times b + f$ $2 \times 4.50 + 3.25$	
2) 4 hot dogs, 2 pogos		
3) 5 fries, 2 pogos		
4) 3 burgers, 2 fries, 2 pogos		
5) 3 fries, 5 burgers, 4 hot dogs		
6) 10 burgers, 10 fries		
7) 5 hot dogs, 7 fries, 3 pogos		
8) 4 burgers, 9 hot dogs		

Evaluating Algebraic Expressions – (x +)

Part 1

Evaluate for $x = -3$. Use brackets to separate the numbers.

1) $7x$	2) $-6x$	3) $4x - 5$	4) $12x + 7$
5) $17x$	6) $15x - 10$	7) $8x - x$	8) $13x + 6 - x$

Part 2

Evaluate the expressions for $y = -8$

1) $\frac{x}{y}$	2) $\frac{16}{y}$	4) $\frac{x}{y} + 5$
5) $\frac{48}{x} + 7$	6) $\frac{88}{x} + y$	7) $\frac{y}{x} + y$

Challenge!

Use three -5s and any operation or brackets to write an expression with the values provided.

	Your Expressions	Value
1)		-125
2)		-5
3)		0
4)		50

	Your Expressions	Value
5)		5
6)		30
7)		20
8)		-6

Matching Game: Do The Equations Match?

Objective

What are we learning about?

To enhance students' understanding of equivalent equations. Students will identify and match pairs of equations that yield the same result, fostering critical thinking and problem-solving skills in a collaborative group setting.

Materials

What do you need for the activity?

- Pre-prepared pre-cut matching cards
- Small bags or envelopes to hold the cards for each group



Instructions

How will you complete the activity?

1. Before the class, the teacher will cut out the pre-prepared matching game cards.
2. Divide the students into small groups and give each group a small envelope containing a set of the matching cards.
3. In their groups, students will spread out the cards face down on their table.
4. Each person takes a turn to try to match two cards. They will need to solve both equations to see if they match (equal the same).
5. If they find a correct match, they keep the cards out and continue with their next turn. If the cards don't match, they turn them back over in the same place, and the next player takes a turn.
6. The activity continues until all pairs are correctly matched within each group.

Cards

Matching Game Cards

$$60 + (-15) + 20$$

$$55 - (-10)$$

PREVIEW

$$100 + (-25)$$

$$90 + (-20) + 12$$

$$52 + 20 + 30$$

$$-104 + 151 + 112$$

$$366 - 150 - 57$$

$$20 + 180$$

$$250 - 50$$

Cards

Matching Game Cards

$$98 + (-43)$$

$$75 + 20 - 40$$

$$89 - 49 + 18$$

$$290 - 99$$

$$-83 + 249$$

$$199 + (-66) + 33$$

$$77 - 25 + 12$$

$$40 + 24 - 0$$

PREVIEW

Finding The Value of a Variable

When we write an algebraic expression with an equal sign, it becomes an equation. An equation is a statement that two expressions are equal.

We can solve for a variable by balancing an equation, making sure both sides of the equal sign have the same value.

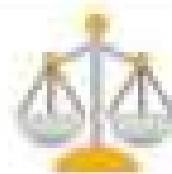

Part 1 Find out the value of the variable.

1) $n - 17 = 23$ $n =$	2) $n + 15 = 29$ $n =$	3) $36 - n = 28$ $n =$
4) $45 - 17 = p$ $p =$	5) $12 + p = 62$ $p =$	6) $p - 13 = (-25)$ $p =$
7) $13 - y = (-10)$ $y =$	8) $17 - y = 2$ $y =$	9) $(-32) - 15 = y$ $y =$
10) $27 + t = (-12)$ $t =$	11) $36 - t = (-2)$ $t =$	12) $7 + t = (-49)$ $t =$

Part 2

The formula for calculating the surface area of a rectangular prism is $s = 2a^2 + 2b^2 + 2c^2$. To find the surface area, add the areas of each side together.

Use the following equation to find the surface area (s) of a rectangular prism:

$$s = a^2 + a^2 + b^2 + b^2 + c^2 + c^2 \quad \text{or} \quad s = 2a^2 + 2b^2 + 2c^2$$

1) $a=6$ $b=11$ $c=10$	SA=	4) $a=26$ $b=15$ $c=41$	SA=
2) $a=9$ $b=14$ $c=21$	SA=	5) $a=35$ $b=32$ $c=49$	SA=
3) $a=11$ $b=21$ $c=25$	SA=	6) $a=29$ $b=19$ $c=52$	SA=

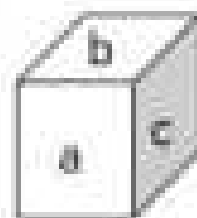

Addition Equations – Golf Tournament - Challenge

Jack hosted a 4-round golf tournament. He has the results and needs to find out who won the tournament. The leaderboard is below but is missing numbers.

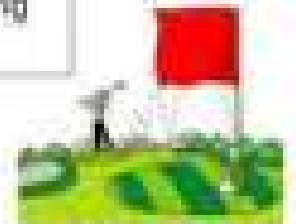

Directions

Fill in the leaderboard.

Player	Round 1	Round 2	Round 3	Round 4	Final Score
Riley		-6	4	-5	
Charlie		-2	5		-5
Dominic				9	-6
Kayden	-3	-7	-1	-5	
Silas	5	1			-1
Lillian	5	8			9
Brooklyn	-4	-2			-5
Natalie		7	1	-6	-4
Andrew	-5	4	1		
Santiago		-3	-8		-22

Results

Who won the golf tournament?

1) Who won the golf tournament?

2) The entry fee for the tournament was \$75. All the money went to the prize (p). Write an equation that determines the value for (p).

3) More golfers joined the tournament. The prize ended up being \$1125. Write an equation that determines how many golfers (g) participated in the tournament.

Integer Patterns – Average Temperatures

Directions

Answer the questions below.



6 friends participated in a 4-round golf tournament. The table below shows what each friend scored.

Player	Round 1	Round 2	Round 3	Round 4	Final Score
Kylie	-3	-5	+4	-4	
Finn	-3	+2	+5	-6	
Maggie		-3	+1	+7	
Dawson (d)		-9	-2	-4	
Zayn (z)			-8	+5	
Leon (l)			-6	+4	

- a) Fill in their final scores.
- b) Write an equation that shows the difference between Finn's (f) final score and Zayn's (z) final score. Use variables that vary before you solve.
- c) Suppose Kylie and Maggie played on a team against Dawson and Zayn. Write an equation that shows the difference between their team scores.
- d) Suppose Dawson and Zayn were on a team against Leon and Finn. Write an equation that shows the difference between their team scores.
- e) Suppose Kylie, Finn, and Maggie played on a team against Dawson, Zayn, and Leon. Write an equation that shows the difference between their team scores.
- f) Use the variables b for best round and w for worst round to write an equation that finds the difference between the best and worst players.



Adding and Subtracting Equations – Flow Chart

We can use a reverse flow chart to calculate the value of a variable in an equation.

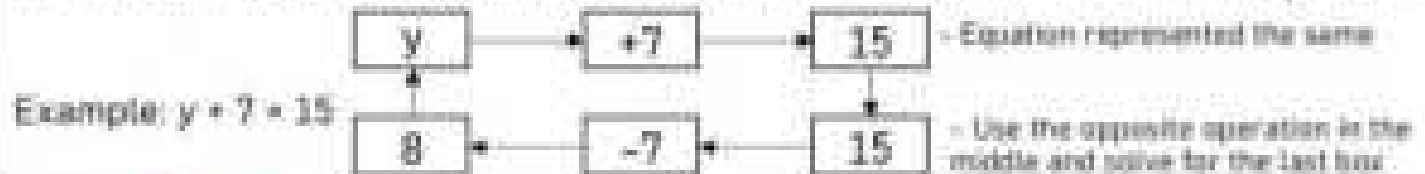

Direction: Use the flow chart to find the value of the variable

1) $t - 7 = 12$	<table style="width: 100%; border-collapse: collapse;"> <tr> <td style="border: 1px solid black; padding: 5px; text-align: center;">t</td> <td style="padding: 0 10px;">→</td> <td style="border: 1px solid black; padding: 5px; text-align: center;">+7</td> <td style="padding: 0 10px;">→</td> <td style="border: 1px solid black; padding: 5px; text-align: center;">12</td> </tr> <tr> <td style="padding: 0 10px;">↓</td> <td></td> <td></td> <td></td> <td style="padding: 0 10px;">↓</td> </tr> <tr> <td style="border: 1px solid black; padding: 5px; text-align: center;"> </td> <td style="padding: 0 10px;">←</td> <td style="border: 1px solid black; padding: 5px; text-align: center;">-7</td> <td style="padding: 0 10px;">←</td> <td style="border: 1px solid black; padding: 5px; text-align: center;">12</td> </tr> </table>	t	→	+7	→	12	↓				↓		←	-7	←	12	7) $t - 13 = -5$	<table style="width: 100%; border-collapse: collapse;"> <tr> <td style="border: 1px solid black; padding: 5px; text-align: center;">t</td> <td style="padding: 0 10px;">→</td> <td style="border: 1px solid black; padding: 5px; text-align: center;">-13</td> <td style="padding: 0 10px;">→</td> <td style="border: 1px solid black; padding: 5px; text-align: center;">-5</td> </tr> <tr> <td style="padding: 0 10px;">↓</td> <td></td> <td></td> <td></td> <td style="padding: 0 10px;">↓</td> </tr> <tr> <td style="border: 1px solid black; padding: 5px; text-align: center;"> </td> <td style="padding: 0 10px;">←</td> <td style="border: 1px solid black; padding: 5px; text-align: center;">+13</td> <td style="padding: 0 10px;">←</td> <td style="border: 1px solid black; padding: 5px; text-align: center;">-5</td> </tr> </table>	t	→	-13	→	-5	↓				↓		←	+13	←	-5
t	→	+7	→	12																													
↓				↓																													
	←	-7	←	12																													
t	→	-13	→	-5																													
↓				↓																													
	←	+13	←	-5																													
2) $r - 9 = 16$	<table style="width: 100%; border-collapse: collapse;"> <tr> <td style="border: 1px solid black; padding: 5px; text-align: center;">r</td> <td style="padding: 0 10px;">→</td> <td style="border: 1px solid black; padding: 5px; text-align: center;">+16</td> <td style="padding: 0 10px;">→</td> <td style="border: 1px solid black; padding: 5px; text-align: center;">16</td> </tr> <tr> <td style="padding: 0 10px;">↓</td> <td></td> <td></td> <td></td> <td style="padding: 0 10px;">↓</td> </tr> <tr> <td style="border: 1px solid black; padding: 5px; text-align: center;"> </td> <td style="padding: 0 10px;">←</td> <td style="border: 1px solid black; padding: 5px; text-align: center;">-9</td> <td style="padding: 0 10px;">←</td> <td style="border: 1px solid black; padding: 5px; text-align: center;">16</td> </tr> </table>	r	→	+16	→	16	↓				↓		←	-9	←	16	8) $r + 16 = 38$	<table style="width: 100%; border-collapse: collapse;"> <tr> <td style="border: 1px solid black; padding: 5px; text-align: center;">r</td> <td style="padding: 0 10px;">→</td> <td style="border: 1px solid black; padding: 5px; text-align: center;">+16</td> <td style="padding: 0 10px;">→</td> <td style="border: 1px solid black; padding: 5px; text-align: center;">38</td> </tr> <tr> <td style="padding: 0 10px;">↓</td> <td></td> <td></td> <td></td> <td style="padding: 0 10px;">↓</td> </tr> <tr> <td style="border: 1px solid black; padding: 5px; text-align: center;"> </td> <td style="padding: 0 10px;">←</td> <td style="border: 1px solid black; padding: 5px; text-align: center;">-16</td> <td style="padding: 0 10px;">←</td> <td style="border: 1px solid black; padding: 5px; text-align: center;">38</td> </tr> </table>	r	→	+16	→	38	↓				↓		←	-16	←	38
r	→	+16	→	16																													
↓				↓																													
	←	-9	←	16																													
r	→	+16	→	38																													
↓				↓																													
	←	-16	←	38																													
3) $c + 11 = 17$	<table style="width: 100%; border-collapse: collapse;"> <tr> <td style="border: 1px solid black; padding: 5px; text-align: center;">c</td> <td style="padding: 0 10px;">→</td> <td style="border: 1px solid black; padding: 5px; text-align: center;">+11</td> <td style="padding: 0 10px;">→</td> <td style="border: 1px solid black; padding: 5px; text-align: center;">17</td> </tr> <tr> <td style="padding: 0 10px;">↓</td> <td></td> <td></td> <td></td> <td style="padding: 0 10px;">↓</td> </tr> <tr> <td style="border: 1px solid black; padding: 5px; text-align: center;"> </td> <td style="padding: 0 10px;">←</td> <td style="border: 1px solid black; padding: 5px; text-align: center;">-11</td> <td style="padding: 0 10px;">←</td> <td style="border: 1px solid black; padding: 5px; text-align: center;">17</td> </tr> </table>	c	→	+11	→	17	↓				↓		←	-11	←	17	9) $c - 12 = -2$	<table style="width: 100%; border-collapse: collapse;"> <tr> <td style="border: 1px solid black; padding: 5px; text-align: center;">c</td> <td style="padding: 0 10px;">→</td> <td style="border: 1px solid black; padding: 5px; text-align: center;">-12</td> <td style="padding: 0 10px;">→</td> <td style="border: 1px solid black; padding: 5px; text-align: center;">-2</td> </tr> <tr> <td style="padding: 0 10px;">↓</td> <td></td> <td></td> <td></td> <td style="padding: 0 10px;">↓</td> </tr> <tr> <td style="border: 1px solid black; padding: 5px; text-align: center;"> </td> <td style="padding: 0 10px;">←</td> <td style="border: 1px solid black; padding: 5px; text-align: center;">+12</td> <td style="padding: 0 10px;">←</td> <td style="border: 1px solid black; padding: 5px; text-align: center;">-2</td> </tr> </table>	c	→	-12	→	-2	↓				↓		←	+12	←	-2
c	→	+11	→	17																													
↓				↓																													
	←	-11	←	17																													
c	→	-12	→	-2																													
↓				↓																													
	←	+12	←	-2																													
4) $b + 12 = 5$	<table style="width: 100%; border-collapse: collapse;"> <tr> <td style="border: 1px solid black; padding: 5px; text-align: center;">b</td> <td style="padding: 0 10px;">→</td> <td style="border: 1px solid black; padding: 5px; text-align: center;">+12</td> <td style="padding: 0 10px;">→</td> <td style="border: 1px solid black; padding: 5px; text-align: center;">5</td> </tr> <tr> <td style="padding: 0 10px;">↓</td> <td></td> <td></td> <td></td> <td style="padding: 0 10px;">↓</td> </tr> <tr> <td style="border: 1px solid black; padding: 5px; text-align: center;"> </td> <td style="padding: 0 10px;">←</td> <td style="border: 1px solid black; padding: 5px; text-align: center;">-12</td> <td style="padding: 0 10px;">←</td> <td style="border: 1px solid black; padding: 5px; text-align: center;">5</td> </tr> </table>	b	→	+12	→	5	↓				↓		←	-12	←	5	10) $b + 14 = 31$	<table style="width: 100%; border-collapse: collapse;"> <tr> <td style="border: 1px solid black; padding: 5px; text-align: center;">b</td> <td style="padding: 0 10px;">→</td> <td style="border: 1px solid black; padding: 5px; text-align: center;">+14</td> <td style="padding: 0 10px;">→</td> <td style="border: 1px solid black; padding: 5px; text-align: center;">31</td> </tr> <tr> <td style="padding: 0 10px;">↓</td> <td></td> <td></td> <td></td> <td style="padding: 0 10px;">↓</td> </tr> <tr> <td style="border: 1px solid black; padding: 5px; text-align: center;"> </td> <td style="padding: 0 10px;">←</td> <td style="border: 1px solid black; padding: 5px; text-align: center;">-14</td> <td style="padding: 0 10px;">←</td> <td style="border: 1px solid black; padding: 5px; text-align: center;">31</td> </tr> </table>	b	→	+14	→	31	↓				↓		←	-14	←	31
b	→	+12	→	5																													
↓				↓																													
	←	-12	←	5																													
b	→	+14	→	31																													
↓				↓																													
	←	-14	←	31																													
5) $p - 9 = 21$	<table style="width: 100%; border-collapse: collapse;"> <tr> <td style="border: 1px solid black; padding: 5px; text-align: center;">p</td> <td style="padding: 0 10px;">→</td> <td style="border: 1px solid black; padding: 5px; text-align: center;">-9</td> <td style="padding: 0 10px;">→</td> <td style="border: 1px solid black; padding: 5px; text-align: center;">21</td> </tr> <tr> <td style="padding: 0 10px;">↓</td> <td></td> <td></td> <td></td> <td style="padding: 0 10px;">↓</td> </tr> <tr> <td style="border: 1px solid black; padding: 5px; text-align: center;"> </td> <td style="padding: 0 10px;">←</td> <td style="border: 1px solid black; padding: 5px; text-align: center;">+9</td> <td style="padding: 0 10px;">←</td> <td style="border: 1px solid black; padding: 5px; text-align: center;">21</td> </tr> </table>	p	→	-9	→	21	↓				↓		←	+9	←	21	11) $p + 8 = 5$	<table style="width: 100%; border-collapse: collapse;"> <tr> <td style="border: 1px solid black; padding: 5px; text-align: center;">p</td> <td style="padding: 0 10px;">→</td> <td style="border: 1px solid black; padding: 5px; text-align: center;">+8</td> <td style="padding: 0 10px;">→</td> <td style="border: 1px solid black; padding: 5px; text-align: center;">5</td> </tr> <tr> <td style="padding: 0 10px;">↓</td> <td></td> <td></td> <td></td> <td style="padding: 0 10px;">↓</td> </tr> <tr> <td style="border: 1px solid black; padding: 5px; text-align: center;"> </td> <td style="padding: 0 10px;">←</td> <td style="border: 1px solid black; padding: 5px; text-align: center;">-8</td> <td style="padding: 0 10px;">←</td> <td style="border: 1px solid black; padding: 5px; text-align: center;">5</td> </tr> </table>	p	→	+8	→	5	↓				↓		←	-8	←	5
p	→	-9	→	21																													
↓				↓																													
	←	+9	←	21																													
p	→	+8	→	5																													
↓				↓																													
	←	-8	←	5																													
6) $x + 16 = 11$	<table style="width: 100%; border-collapse: collapse;"> <tr> <td style="border: 1px solid black; padding: 5px; text-align: center;">x</td> <td style="padding: 0 10px;">→</td> <td style="border: 1px solid black; padding: 5px; text-align: center;">+16</td> <td style="padding: 0 10px;">→</td> <td style="border: 1px solid black; padding: 5px; text-align: center;">11</td> </tr> <tr> <td style="padding: 0 10px;">↓</td> <td></td> <td></td> <td></td> <td style="padding: 0 10px;">↓</td> </tr> <tr> <td style="border: 1px solid black; padding: 5px; text-align: center;"> </td> <td style="padding: 0 10px;">←</td> <td style="border: 1px solid black; padding: 5px; text-align: center;">-16</td> <td style="padding: 0 10px;">←</td> <td style="border: 1px solid black; padding: 5px; text-align: center;">11</td> </tr> </table>	x	→	+16	→	11	↓				↓		←	-16	←	11	12) $x - 7 = -3$	<table style="width: 100%; border-collapse: collapse;"> <tr> <td style="border: 1px solid black; padding: 5px; text-align: center;">x</td> <td style="padding: 0 10px;">→</td> <td style="border: 1px solid black; padding: 5px; text-align: center;">-7</td> <td style="padding: 0 10px;">→</td> <td style="border: 1px solid black; padding: 5px; text-align: center;">-3</td> </tr> <tr> <td style="padding: 0 10px;">↓</td> <td></td> <td></td> <td></td> <td style="padding: 0 10px;">↓</td> </tr> <tr> <td style="border: 1px solid black; padding: 5px; text-align: center;"> </td> <td style="padding: 0 10px;">←</td> <td style="border: 1px solid black; padding: 5px; text-align: center;">+7</td> <td style="padding: 0 10px;">←</td> <td style="border: 1px solid black; padding: 5px; text-align: center;">-3</td> </tr> </table>	x	→	-7	→	-3	↓				↓		←	+7	←	-3
x	→	+16	→	11																													
↓				↓																													
	←	-16	←	11																													
x	→	-7	→	-3																													
↓				↓																													
	←	+7	←	-3																													

Math Tic-Tac-Toe: Balance The Equations

Objective

What are we learning about?

To help students practice solving and balancing equations involving variables in a fun and interactive way through a Tic-Tac-Toe game.

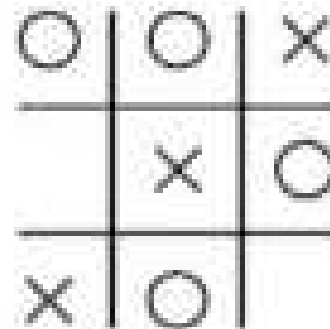

Materials

What do you need for the activity?

- Tic-Tac-Toe boards (provided)

Instructions

How will you complete the activity?

1. Find a partner to play the game.
2. The goal is to solve and balance the algebraic equation in each square to place your marker (X or O).
3. One player will be "X" and the other will be "O".
4. Take turns choosing a square and solving the equation in that square. Find the value of the variable.
5. Write down the solution below the equation and place your marker (X or O) in the square.
6. If a player chooses a square and solves the equation incorrectly, they do not get to place their marker in that square. The other player gets a chance to solve it correctly and place their marker.
7. The first player to get three markers in a row (horizontally, vertically, and diagonally) wins the game. Continue playing with different tic-tac-toe grids on the sheet.

Tic-Tac-Toe

Use the following tic-tac-toe grids for the game.

$76 = \underline{\quad} + 16$	$(-12) + \underline{\quad} = 60$	$\underline{\quad} + 6 = 12$
$(-42) + \underline{\quad} = 84$	$48 + (-8) = \underline{\quad}$	$\underline{\quad} \times 5 = 25$
$380 = \underline{\quad} + 10$	$(-45) = \underline{\quad}$	$\underline{\quad} + 7 = (-9)$

$128 = \underline{\quad} + 16$	$(-28) + \underline{\quad} = 72$	$\underline{\quad} + 4 = 8$
$(-34) + \underline{\quad} = 308$	$75 + (-15) = \underline{\quad}$	$\underline{\quad} + 6 = 36$
$110 = \underline{\quad} + (-11)$	$(-29) + (-8) = \underline{\quad}$	$\underline{\quad} + 10 = (-6)$

$180 = \underline{\quad} + 16$	$(-2) + \underline{\quad} = 48$	$\underline{\quad} + 4 = 10$
$(-38) + \underline{\quad} = 90$	$54 + (-6) = \underline{\quad}$	$\underline{\quad} + 12 = 18$
$200 = \underline{\quad} + (-10)$	$(-44) + (-3) = \underline{\quad}$	$\underline{\quad} - 2 = (-10)$

$72 = \underline{\quad} + 9$	$(-15) + \underline{\quad} = 60$	$\underline{\quad} + 4 = 10$
$(-27) + \underline{\quad} = 108$	$80 + (-8) = \underline{\quad}$	$\underline{\quad} + 14 = 98$
$135 = \underline{\quad} + (-15)$	$(-12) + \underline{\quad} = 48$	$\underline{\quad} + 6 = (-5)$

$68 = \underline{\quad} + 8$	$(-21) + \underline{\quad} = 105$	$\underline{\quad} + 7 = 9$
$(-14) + \underline{\quad} = 60$	$60 + (-10) = \underline{\quad}$	$\underline{\quad} + 11 = 88$
$72 = \underline{\quad} + (-6)$	$(-40) + (-6) = \underline{\quad}$	$\underline{\quad} + 3 = (-8)$

$64 = \underline{\quad} + 16$	$(-20) + \underline{\quad} = 100$	$\underline{\quad} + 8 = 9$
$(-28) + \underline{\quad} = 56$	$100 + (-25) = \underline{\quad}$	$\underline{\quad} + 7 = 28$
$90 = \underline{\quad} + (-9)$	$(-24) + (-2) = \underline{\quad}$	$\underline{\quad} + 12 = (-6)$

PREVIEW

Finding The Value of a Variable

When we multiply a number by a variable, we do not need to use the multiplication sign. It is known that any variable next to a number means the operation we are using is multiplication.

Example: $7n = 14$ means $7 \times n = 14$

We can figure out the unknown number by balancing the equation: $n = 2$

Part 1 Find out the value of the variable.

1) $4n = 16$ $n =$	2) $(-4n) = 16$ $n =$	3) $(-9s) = 54$ $s =$
4) $3x(-4) = 12$ $x =$	5) $\frac{-12}{p} = -11$ $p =$	6) $\frac{-28}{k} = -7$ $k =$
7) $(-3n) = (-12)$ $n =$	8) $(-42) = (-7n)$ $n =$	9) $\frac{p}{8} = -9$ $p =$
10) $\frac{-40}{5} = n$ $n =$	11) $\frac{12}{p} = -4$ $p =$	12) $\frac{z}{18} = -5$ $p =$
13) $(-8n) = 96$ $n =$	14) $\frac{110}{n} = -11$ $n =$	15) $7d = 56$ $d =$

Part 2 Calculate the area of a circle and a triangle.

The formula for calculating the area of a circle is: $A = \pi r^2$ where $\pi = 3.14$
Calculate the area in the questions below using the values for radius and pi

	Radius	Area - Circle		Radius	Area - Circle		Radius	Area - Circle
1)	$r = 9\text{cm}$	$A =$	3)	$r = 12\text{cm}$	$A =$	5)	$r = 13\text{cm}$	$A =$
2)	$r = 6\text{cm}$	$A =$	4)	$r = 7\text{cm}$	$A =$	6)	$r = 11\text{cm}$	$A =$

The formula for calculating the area of a triangle is: $A = \frac{bh}{2}$

	b	h	Area - Triangle		b	h	Area - Triangle		b	h	Area - Triangle
1)	6	2	$A =$	3)	8	4	$A =$	5)	3	4	$A =$
2)	9	6	$A =$	4)	7	5	$A =$	6)	8	6	$A =$

Writing Multiplication Equations – Gas Station

Tyler works at a gas station. He sells fuel by the litre, chips, drinks, and chocolate bars.

Fuel (f)	Chips (c)	Drinks (d)	Chocolate Bars (b)
\$1.33/L	\$1.75	\$1.25	\$1.99
			

Instructions: Complete the table below. The first one is done for you.

#	f	c	d	b	Equation	Answer
1	20	2	0	0	$t = 20 \times 1.33 + 2 \times 1.75$ $t = 26.6 + 3.50$ $t = \$30.1$	
2	50	0	3	2		
3	0	2	1	0		
4	60	1	2	2		
5	0	2	0	0		
6	0	1	1	0		
7	25	2	1	2		
8	70	0	1	3		

Multiplying Equations – Flow Chart

Steps to fill in a flow chart:

- 1) Write the variable in the first box
- 2) Write the second value in the second box
- 3) Write the answer in the third box
- 4) We are working in reverse now. Write the answer in the first box
- 5) We do the opposite to the next box as we did with the second box
- 6) Fill in the last box to find the value of the variable, which it points to

Example: $7t = 28$

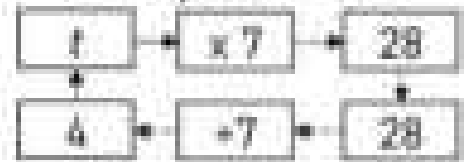

Directions: Fill in the blanks in the flow chart.

1) $7t = 28$		2) $12t = -84$	
3) $3r = 15$		4) $-55 = 55$	
5) $-9c = 36$		6) $-7c = 63$	
7) $-6b = -42$		8) $-12b = -132$	
9) $8p = -72$		10) $-9n = 63$	

Writing Division Equations - Investments

An investment club is a group of investors who pool their money to make investments. Each member of the group helps study new investment opportunities. When an investment earns money, they split the earnings. When an investment loses money, they split the losses.



Instructions

Use a formula to find out the balance for each person in the club.

#	Investment	# of People in the Club (n)	Formula	Answer
1	\$400 loss	8	$\frac{i}{n} = t$	$\frac{-400}{8} = -50$
2	\$600 gain			
3	\$800 loss	5		
4	\$1200 loss	8		
5	\$ 750 gain	6		
6	\$5000 gain	20		
7	\$2500 loss	25		
8	\$3600 loss	24		
9	\$12500 gain	5		
10	\$8000 gain	40		
11	\$6800 loss	17		
12	\$25000 loss	20		
13	\$84000 gain	16		

Division Equations – Flow Chart

Directions

Fill in the blanks in the flow chart.



1) $\frac{t}{-6} = 4$	$\begin{array}{ccccc} & \boxed{t} & \leftarrow & x = -6 & \leftarrow & \boxed{4} \\ & \uparrow & & & & \downarrow \\ -24 & \leftarrow & x = -6 & \leftarrow & \boxed{4} \end{array}$	7) $\frac{t}{8} = -4$	$\begin{array}{ccccc} & \boxed{} & \leftarrow & \boxed{} & \leftarrow & \boxed{} \\ & \uparrow & & & & \downarrow \\ \boxed{} & \leftarrow & \boxed{} & \leftarrow & \boxed{} \end{array}$
2) $\frac{r}{-7} = 4$	$\begin{array}{ccccc} & \boxed{} & \leftarrow & \boxed{} & \leftarrow & \boxed{} \\ & \uparrow & & & & \downarrow \\ \boxed{} & \leftarrow & \boxed{} & \leftarrow & \boxed{} \end{array}$	8) $\frac{r}{-12} = 9$	$\begin{array}{ccccc} & \boxed{} & \leftarrow & \boxed{} & \leftarrow & \boxed{} \\ & \uparrow & & & & \downarrow \\ \boxed{} & \leftarrow & \boxed{} & \leftarrow & \boxed{} \end{array}$
3) $\frac{c}{4} = -7$	$\begin{array}{ccccc} & \boxed{} & \leftarrow & \boxed{} & \leftarrow & \boxed{} \\ & \uparrow & & & & \downarrow \\ \boxed{} & \leftarrow & \boxed{} & \leftarrow & \boxed{} \end{array}$	9) $\frac{c}{-5} = -7$	$\begin{array}{ccccc} & \boxed{} & \leftarrow & \boxed{} & \leftarrow & \boxed{} \\ & \uparrow & & & & \downarrow \\ \boxed{} & \leftarrow & \boxed{} & \leftarrow & \boxed{} \end{array}$
4) $\frac{b}{11} = 6$	$\begin{array}{ccccc} & \boxed{} & \leftarrow & \boxed{} & \leftarrow & \boxed{} \\ & \uparrow & & & & \downarrow \\ \boxed{} & \leftarrow & \boxed{} & \leftarrow & \boxed{} \end{array}$	10) $\frac{b}{-15} = 4$	$\begin{array}{ccccc} & \boxed{} & \leftarrow & \boxed{} & \leftarrow & \boxed{} \\ & \uparrow & & & & \downarrow \\ \boxed{} & \leftarrow & \boxed{} & \leftarrow & \boxed{} \end{array}$
5) $\frac{p}{-7} = -12$	$\begin{array}{ccccc} & \boxed{} & \leftarrow & \boxed{} & \leftarrow & \boxed{} \\ & \uparrow & & & & \downarrow \\ \boxed{} & \leftarrow & \boxed{} & \leftarrow & \boxed{} \end{array}$	11) $\frac{p}{8} = 12$	$\begin{array}{ccccc} & \boxed{} & \leftarrow & \boxed{} & \leftarrow & \boxed{} \\ & \uparrow & & & & \downarrow \\ \boxed{} & \leftarrow & \boxed{} & \leftarrow & \boxed{} \end{array}$
6) $\frac{n}{-2} = -33$	$\begin{array}{ccccc} & \boxed{} & \leftarrow & \boxed{} & \leftarrow & \boxed{} \\ & \uparrow & & & & \downarrow \\ \boxed{} & \leftarrow & \boxed{} & \leftarrow & \boxed{} \end{array}$	12) $\frac{n}{-13} = -6$	$\begin{array}{ccccc} & \boxed{} & \leftarrow & \boxed{} & \leftarrow & \boxed{} \\ & \uparrow & & & & \downarrow \\ \boxed{} & \leftarrow & \boxed{} & \leftarrow & \boxed{} \end{array}$

PREVIEW

Mixed Operations - BEDMAS

When solving an equation, you need to follow the order of operations. This means you have to solve the equation in the correct order, not just from left to right. Using BEDMAS helps us remember the order to solve.

1. Brackets 2. Exponents 3. Division or Multiplication (whichever is first) 4. Addition or Subtraction (whichever is first)

Example 1

$$2 + (3 \times 4)$$

$$2 + 12$$

$$n = 14$$

Example 2

$$n - (2 \times 3) = 4$$

$$n - 6 = 4$$

$$n = 10$$

Example 3

$$(4n) - 8 = 20$$

$$4 \times 7 - 8 = 20$$

$$n = 7$$

Questions

Solve each equation for the variables using BEDMAS.

1) $9 + (4 \times 5) = n$

3) $(9 \times 6) + (12 + n) = 58$

4) $n + (32 - 8) = 12$

5) $5(2 + p) = 45$

7) $46 + t + (7 + 11) = 24$

8) $32 - (3n + 16) = 1$

9) $24 - (n \times 5) = 4$

10) $\frac{18 + n - 4}{4} = 5$

11) $\frac{9n + 8}{3} = 24$

12) $24 - 15 + (t \times 3) = 27$

Division Equations – Flow Chart

Directions

Fill in the blanks in the flow chart.

1) $2(5 + 7n) = 66$	<div style="display: flex; justify-content: space-around; align-items: center;"> <div style="border: 1px solid black; padding: 5px; text-align: center;">n</div> <div style="border: 1px solid black; padding: 5px; text-align: center;">x 7</div> <div style="border: 1px solid black; padding: 5px; text-align: center;">+ 5</div> <div style="border: 1px solid black; padding: 5px; text-align: center;">x 2</div> <div style="border: 1px solid black; padding: 5px; text-align: center;">= 66</div> </div> <div style="display: flex; justify-content: space-around; align-items: center; margin-top: 5px;"> <div style="border: 1px solid black; padding: 5px; text-align: center;">4</div> <div style="border: 1px solid black; padding: 5px; text-align: center;">+ 7</div> <div style="border: 1px solid black; padding: 5px; text-align: center;">- 5</div> <div style="border: 1px solid black; padding: 5px; text-align: center;">+ 2</div> <div style="border: 1px solid black; padding: 5px; text-align: center;">= 66</div> </div>
2) $3(1 + 2n) = 27$	<div style="display: flex; justify-content: space-around; align-items: center;"> <div style="border: 1px solid black; width: 40px; height: 20px;"></div> <div style="border: 1px solid black; width: 40px; height: 20px;"></div> <div style="border: 1px solid black; width: 40px; height: 20px;"></div> <div style="border: 1px solid black; width: 40px; height: 20px;"></div> <div style="border: 1px solid black; width: 40px; height: 20px;"></div> </div> <div style="display: flex; justify-content: space-around; align-items: center; margin-top: 5px;"> <div style="border: 1px solid black; width: 40px; height: 20px;"></div> <div style="border: 1px solid black; width: 40px; height: 20px;"></div> <div style="border: 1px solid black; width: 40px; height: 20px;"></div> <div style="border: 1px solid black; width: 40px; height: 20px;"></div> <div style="border: 1px solid black; width: 40px; height: 20px;"></div> </div>
3) $-5(4t - 31) = 10$	<div style="display: flex; justify-content: space-around; align-items: center;"> <div style="border: 1px solid black; width: 40px; height: 20px;"></div> <div style="border: 1px solid black; width: 40px; height: 20px;"></div> <div style="border: 1px solid black; width: 40px; height: 20px;"></div> <div style="border: 1px solid black; width: 40px; height: 20px;"></div> <div style="border: 1px solid black; width: 40px; height: 20px;"></div> </div> <div style="display: flex; justify-content: space-around; align-items: center; margin-top: 5px;"> <div style="border: 1px solid black; width: 40px; height: 20px;"></div> <div style="border: 1px solid black; width: 40px; height: 20px;"></div> <div style="border: 1px solid black; width: 40px; height: 20px;"></div> <div style="border: 1px solid black; width: 40px; height: 20px;"></div> <div style="border: 1px solid black; width: 40px; height: 20px;"></div> </div>
4) $-4\left(\frac{8r}{3} - 6\right) = -24$	<div style="display: flex; justify-content: space-around; align-items: center;"> <div style="border: 1px solid black; width: 40px; height: 20px;"></div> <div style="border: 1px solid black; width: 40px; height: 20px;"></div> <div style="border: 1px solid black; width: 40px; height: 20px;"></div> <div style="border: 1px solid black; width: 40px; height: 20px;"></div> <div style="border: 1px solid black; width: 40px; height: 20px;"></div> </div> <div style="display: flex; justify-content: space-around; align-items: center; margin-top: 5px;"> <div style="border: 1px solid black; width: 40px; height: 20px;"></div> <div style="border: 1px solid black; width: 40px; height: 20px;"></div> <div style="border: 1px solid black; width: 40px; height: 20px;"></div> <div style="border: 1px solid black; width: 40px; height: 20px;"></div> <div style="border: 1px solid black; width: 40px; height: 20px;"></div> </div>
5) $8(3 + 4n) = 88$	<div style="display: flex; justify-content: space-around; align-items: center;"> <div style="border: 1px solid black; width: 40px; height: 20px;"></div> <div style="border: 1px solid black; width: 40px; height: 20px;"></div> <div style="border: 1px solid black; width: 40px; height: 20px;"></div> <div style="border: 1px solid black; width: 40px; height: 20px;"></div> <div style="border: 1px solid black; width: 40px; height: 20px;"></div> </div> <div style="display: flex; justify-content: space-around; align-items: center; margin-top: 5px;"> <div style="border: 1px solid black; width: 40px; height: 20px;"></div> <div style="border: 1px solid black; width: 40px; height: 20px;"></div> <div style="border: 1px solid black; width: 40px; height: 20px;"></div> <div style="border: 1px solid black; width: 40px; height: 20px;"></div> <div style="border: 1px solid black; width: 40px; height: 20px;"></div> </div>
6) $-2(3 - 7y) = 36$	<div style="display: flex; justify-content: space-around; align-items: center;"> <div style="border: 1px solid black; width: 40px; height: 20px;"></div> <div style="border: 1px solid black; width: 40px; height: 20px;"></div> <div style="border: 1px solid black; width: 40px; height: 20px;"></div> <div style="border: 1px solid black; width: 40px; height: 20px;"></div> <div style="border: 1px solid black; width: 40px; height: 20px;"></div> </div> <div style="display: flex; justify-content: space-around; align-items: center; margin-top: 5px;"> <div style="border: 1px solid black; width: 40px; height: 20px;"></div> <div style="border: 1px solid black; width: 40px; height: 20px;"></div> <div style="border: 1px solid black; width: 40px; height: 20px;"></div> <div style="border: 1px solid black; width: 40px; height: 20px;"></div> <div style="border: 1px solid black; width: 40px; height: 20px;"></div> </div>
7) $\frac{8 + 6r}{3} = 15$	<div style="display: flex; justify-content: space-around; align-items: center;"> <div style="border: 1px solid black; width: 40px; height: 20px;"></div> <div style="border: 1px solid black; width: 40px; height: 20px;"></div> <div style="border: 1px solid black; width: 40px; height: 20px;"></div> <div style="border: 1px solid black; width: 40px; height: 20px;"></div> <div style="border: 1px solid black; width: 40px; height: 20px;"></div> </div> <div style="display: flex; justify-content: space-around; align-items: center; margin-top: 5px;"> <div style="border: 1px solid black; width: 40px; height: 20px;"></div> <div style="border: 1px solid black; width: 40px; height: 20px;"></div> <div style="border: 1px solid black; width: 40px; height: 20px;"></div> <div style="border: 1px solid black; width: 40px; height: 20px;"></div> <div style="border: 1px solid black; width: 40px; height: 20px;"></div> </div>
8) $-3(3n - 6) = 45$	<div style="display: flex; justify-content: space-around; align-items: center;"> <div style="border: 1px solid black; width: 40px; height: 20px;"></div> <div style="border: 1px solid black; width: 40px; height: 20px;"></div> <div style="border: 1px solid black; width: 40px; height: 20px;"></div> <div style="border: 1px solid black; width: 40px; height: 20px;"></div> <div style="border: 1px solid black; width: 40px; height: 20px;"></div> </div> <div style="display: flex; justify-content: space-around; align-items: center; margin-top: 5px;"> <div style="border: 1px solid black; width: 40px; height: 20px;"></div> <div style="border: 1px solid black; width: 40px; height: 20px;"></div> <div style="border: 1px solid black; width: 40px; height: 20px;"></div> <div style="border: 1px solid black; width: 40px; height: 20px;"></div> <div style="border: 1px solid black; width: 40px; height: 20px;"></div> </div>

PREVIEW

Mixed Operations - BEDMAS

Questions

Find out the value of the variables using BEDMAS.

1) $-3(y + 6) = -30$	2) $3(11 - 4) + t = 35$	3) $8 + 4 \times 3 + (p) = 15$
4) $-5(n - 7) = 15$	5) $11 - 4 + (n \times 5) = -41$	6) $8(7 + 4) - p = 61$
7) $\frac{49}{4+3} + t = 22$		9) $p + 28 + 12 + 3 = 40$
10) $-5n - (49 + 7) = -47$	11) $\frac{7t+6}{9} + (-1) = 12$	12) $12 \times 5 + p = 23$

Word Problem

Write the equation for the situations below and answer the question.

- 1) Calvin went to the mall with \$65. He bought 3 video games for n number of dollars. He then bought a drink for \$4. He left the mall with \$16. How much did each video game cost?



- 2) Freya ordered two slices of pizza and one soda for lunch. A slice of pizza is \$3.50, and a soda is \$2.00. Freya did the math below. What did she do wrong?

$$\begin{aligned} & \$3.50 + \$2.00 \times 2 = ? \\ & \$5.50 \times 2 = \$11.00 \end{aligned}$$

Mixed Operations - BEDMAS

Word Problems

Write the equation for the situations below and answer the question.

1) Omar is building his YouTube channel. He has some videos on his channel already and made 3 more last weekend. If he triples the number of videos he has, he will have 45 videos in total.

a) Write an equation that represents the problem.

b) How many videos did Omar start with?



2) A group of 9 friends went to the movies. Each movie ticket costs \$11. All 9 friends decided to get a drink and popcorn combo. The total cost for the 9 friend's tickets and drinks was \$171.

a) Write an equation that represents the problem.

b) How much did each drink and popcorn combo cost?



3) A basketball team gets 2 points for a win, 1 point for a tie, and 0 points for a loss. The Vaughan Panthers ended the season with 42 points. They played 30 games.

a) Write an equation that represents the problem.

b) How many games did they win?

c) If they played 30 games in total, how many games did they lose?



Introduction to Inequalities

Inequalities are used to tell the relative size of two expressions or numbers. We can use the greater than sign ($>$), or the smaller than sign ($<$). We can also use a new sign (\geq) to show that a value is equal to or greater/less than the other value.

We often use a number line to graph the range of values that hold true for an inequality. An open dot on a number line is used when an inequality involves "less than" or "greater than", and a closed dot is used when it also includes "equal to".

Examples:

$x < 7$



$x \geq 12$



Questions Graph the inequality on the number line and write the word form.

1) $x \geq 6$



Word Form - x is greater than or equal to 6.

2) $x \leq 11$



Word Form - _____

3) $x < 9$



Word Form - _____

4) $x > 15$



Word Form - _____

5) $x \geq 7$



Word Form - _____

6) $x \leq 8$



Word Form - _____

Inequalities – Multiple Choice**Questions**

Circle the values that satisfy each inequality.

1)

$x > 48$

45 -9 52 -45

2)

$x < 31$

30 33 -8 -32

3)

$x < 2$

21 2 2 2

4)

$x > 75$

74 -76 75 76

5)

$x < -5$

-5 -6 -4 5

$x = 99$

99 97 -2

7)

$x > -27$

-28 -26 -27 -30

8)

$x < -39$

-42 -40 -39

9)

$x = 79$

80 78 81 79

10)

$x > -84$

-83 -85 -84 -86

11)

$x < 87$

88 86 85 -87

12)

$x < 145$

-144 145 -146 143

Introduction to Inequalities



Part 1

Graph the inequality on the number line and write the word form.

1) $x > 9$



Word Form - _____

2) $x \leq 5$



Word Form - _____

3) $x < 12$



Word Form - _____

4) $x > 7$



Word Form - _____

5) $x \geq 14$



Word Form - _____

Part 2

Write the inequality shown by each number line.

1)



Answer

2)



Answer

3)



Answer

4)



Answer

Inequalities in a Set - Addition**Questions**

Which numbers in the set satisfy the inequality?

1) Solve the inequality $x \leq 8$ in the set $\{6, 10, 7, 8, 13, 15, 0\}$ Numbers that fit: $0, 6, 7, 8$ 2) Solve the inequality $x + 12 \leq 19$ in the set $\{8, 4, 7, 9, 3, 6, 10\}$

Numbers that fit: _____

3) Solve the inequality $x + 6 < 15$ in the set $\{-15, -25, -30, -10, -20, -22\}$

Numbers that fit: _____

4) Solve the inequality $x + 47 > 50$ in the set $\{50, 39, 36, 40, 43, 32, -8\}$

Numbers that fit: _____

5) Solve the inequality $x + 8 \leq -21$ in the set $\{-25, -15, -35, 22\}$

Numbers that fit: _____

6) Solve the inequality $x + 47 > 56$ in the set $\{-9, 10, 11, 8, 9, -2\}$

Numbers that fit: _____

7) Solve the inequality $-23 + x > -35$ in the set $\{-10, -15, 12, 16, 22, -13\}$

Numbers that fit: _____

8) Solve the inequality $-32 + x < -41$ in the set $\{-10, -12, 15, 9, -11, -8, -9\}$

Numbers that fit: _____

Solving Inequalities - Subtraction

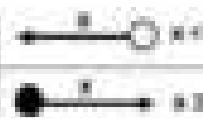
**Questions**

Graph the subtraction inequalities using the number line.

1) $14 - x > 9$



2) $17 - x$



3) x



4) $x - 11 \leq -8$



5) $-17 - x \geq 4$



6) $8 - x > -6$



7) $x - 6 > -5$



8) $(-4) - x \geq 8$



9) $12 - x > -4$



10) $x - 3 \leq -9$



PREVIEW

Inequalities – Adding and Subtracting

Questions

Solve the inequalities below.

1)

$$x > 9 + 14 - 5$$

$$x > 18$$

2)

$$x < 7 \times 4 - 11$$

3)

$$x \leq 30 - 5$$

4)

$$x \geq 25 - 4 \times 3$$

5)

$$x < 6 + 5 - 5 \times 2$$

$$x \leq 14 + 3 - 23$$

7)

$$x > 8 \times 5 + (-2)$$

8)

$$x < 12 - 7$$

9)

$$x \leq 24 + 6 \times (-5)$$

10)

$$x > 61 - 6 + (-15)$$

11)

$$x < -5(4 + 6)$$

12)

$$x < -8(32 + 8)$$

Graphing Inequalities – Multiple Operations

Questions

Graph the inequalities on the number line.

1)

$$x > 8 + 5 - 7$$



2)

$$x < 16 - 4 + (-7)$$



3)

17



4)

$$x > 7 - 9 + 15$$



5)

$$x \geq (-2) \times 5 + 3$$



$$x \leq 6 - (-2) - 4$$



7)

$$x > (-7) \times 2 + (-5)$$



8)



9)

$$x \leq (-20 + -4)(-3)$$



10)

$$x > -15 + 13 - 12$$



11)

$$5(10 \times 2) + 2 < x$$



12)

$$44 + 4 \times 8 - 30 > x$$



Inequalities – Isolating the Variable

Steps to isolate a variable:

1. Add or subtract the same amount from both sides so that the variable is by itself.
2. If the number that is with the variable is positive, you will subtract the same number from both sides.
3. If it is negative, you will add the number to both sides.
4. Since we want the variable on the left, we might need to flip it to the other side at the end. When we do this, we switch the inequality sign from $<$ to $>$ or from $>$ to $<$.

Examples:

$$\begin{aligned}x - 14 &\leq 9 \\x - 14 + 14 &\leq 9 + 14 \\x &\leq 23\end{aligned}$$

$$\begin{aligned}15 + x &= 9 \\15 - 9 + x + 9 &= 9 - 9 \\6 + x &= 0 \\x &= -6\end{aligned}$$

Questions

1)

below

1)

$$x - 5 < 15$$

$$x + 17 < 31$$

3)

$$x + 12 \leq 25$$

4)

$$3 < x$$

5)

$$9 < x + 13$$

6)

$$24 \leq x - 15$$

7)

$$x + 32 > 25$$

8)

$$48 < x + 56$$

Graphing Inequalities – Cartesian Plane – One Variable**Questions**

Graph the inequalities on the cartesian plane.

1) $x > 4$

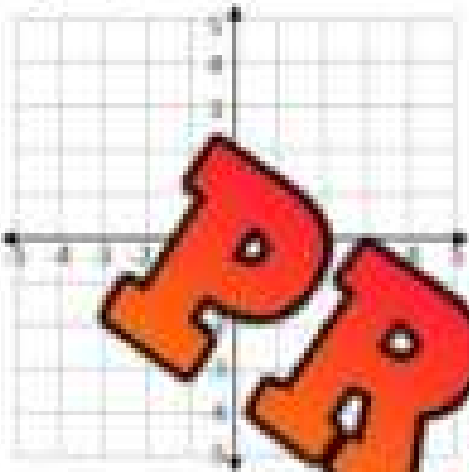

2) $x < -2$

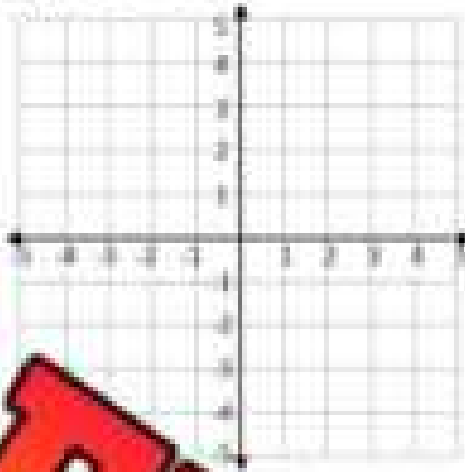

3) $y \leq 4$

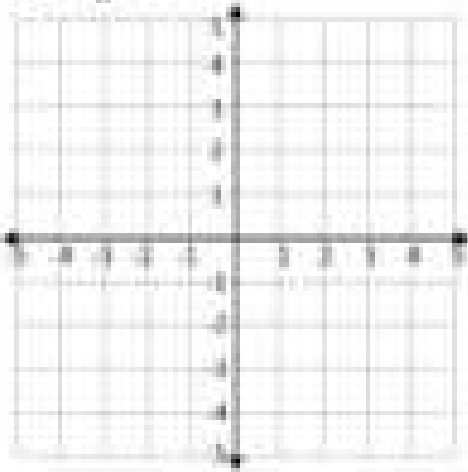

4) $3 + x > 6$

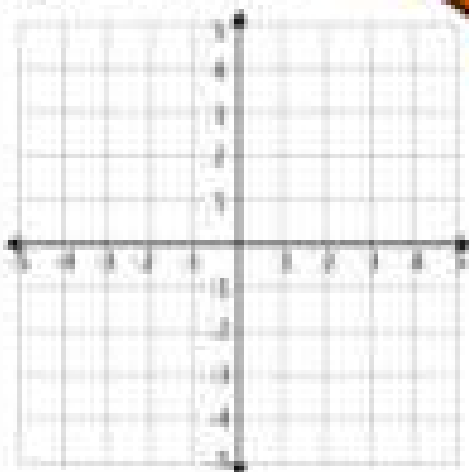

6) $y + 5 \leq 7$

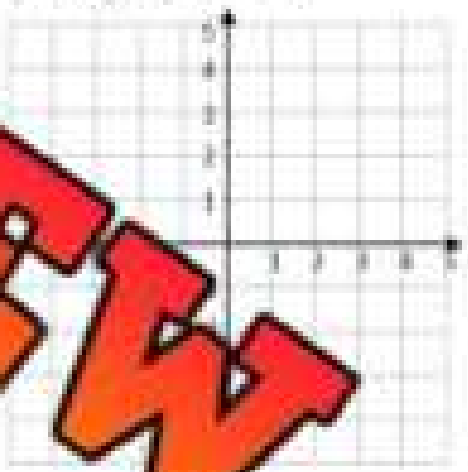

7) $9 + x \geq 11$

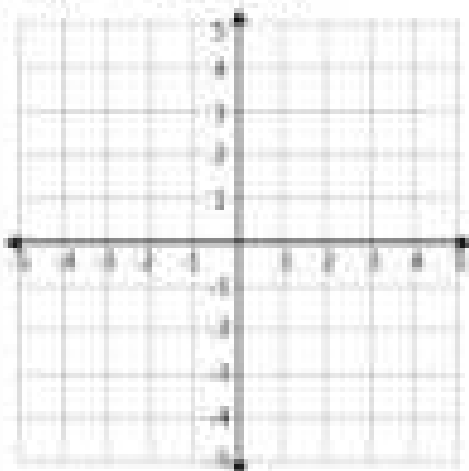

8) $y - 6 < -2$

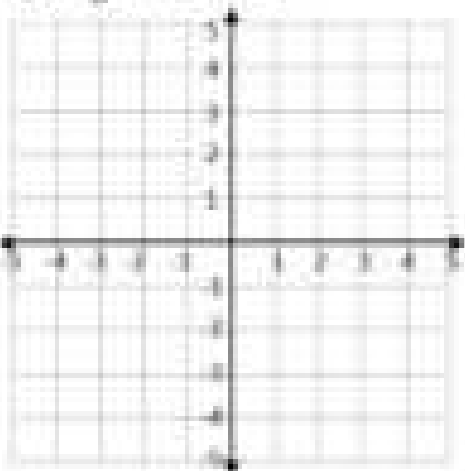

9) $y + (-2) \leq -1$

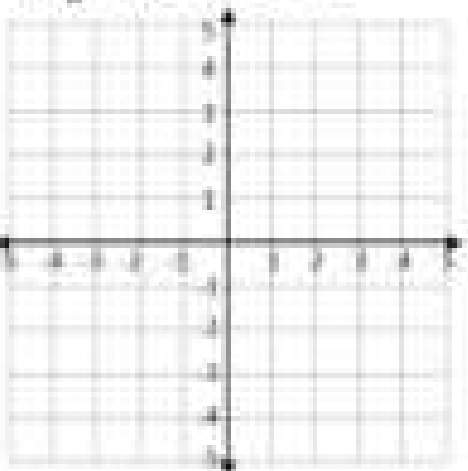
**PREVIEW**

Linear Equations – Table of Values

A **linear equation** is an equation that is written for two different variables. The variables have a relationship where they increase or decrease at the same rate. This means when the variables are plotted on a graph, the line will be straight.

It is helpful to use a table of values to represent the values of both variables. This allows us to see the relationship between the variables. We can find any missing value by using an equation that represents the relationship between the variables. A related pair of x and y values is called an **ordered pair**.

Practice completing the tables using the equations below.

x	y
1	
2	14
3	20
4	
5	
6	

$$1) y = 6x + 2$$

x	y
	-2
2	1
3	
5	
9	

$$2) y = 3x - 5$$

x	y
1	
2	
3	
4	
5	

x	y
1	
2	
3	
4	
5	
9	

$$4) y = 6x - 7$$

x	y
1	
2	
3	
4	
5	
10	

$$5) y = -3x - 4$$

x	y
1	
2	
3	
4	
5	
11	

$$6) y = 5x - (-8)$$

Linear Equations – Table of Values

Practice

 Write the equation that represents the relation between x and y .

x	y
1	2
2	9
3	6
4	
5	
6	

1) _____

x	y
1	-7
2	-11
3	-15
4	-19
5	
6	

x	y
1	-3
2	0
3	3
4	6
5	
11	

3) _____

x	y
1	5
2	8
3	-5
4	-10
5	
9	

4) _____

x	y
1	
2	
3	
4	10
5	
10	

5) _____

x	y
1	-7
2	-18
3	-29
4	-40
5	
10	

6) _____

Practice

Read the problem and represent it in the table of values.

An ice cream shop sells cones for \$3 and toppings for \$2 each. An equation for this relation is $y = 2x + 3$ where the 3 dollars is constant, and the x represents how many toppings are chosen.

a) Fill in the table of values

b) Fill in the ordered pairs below – Remember (x, y)

(1, ___) (2, ___) (3, ___) (6, ___) (12, ___) (20, ___)

x	y
1	
2	
3	
4	
5	

Linear Equations – Table of Values

Practice

Make a table of values for each relation.

1) $y = 3x + 2$

2) $y = 5x - 6$

3) $y = -2x + 3$

4) $y = 4x - 2$

5) $y = 6x - 4$

6) $y = -7x - 8$

Challenge

Can you determine the equation using the

These ordered pairs are in the same linear relation: $(-2, -4)$, $(0, 4)$, $(2, 12)$, $(4, 20)$

a) What is the equation that represents the values in the ordered pairs?

b) Fill in the missing value in the ordered pairs.

$(1, \underline{\quad})$, $(3, \underline{\quad})$, $(8, \underline{\quad})$, $(-4, \underline{\quad})$, $(-8, \underline{\quad})$, $(\underline{\quad}, 56)$, $(\underline{\quad}, -56)$

c) Fill in the table of values for the linear relation.

x	-6	-3	0	5	7	12	15	20
y								

Linear Equations – Graphing 2 Variables

Instructions: Fill in the table of values and then graph the results using ordered pairs.

1) $y = 2x - 2$

x	0	1	2	3	4
y					

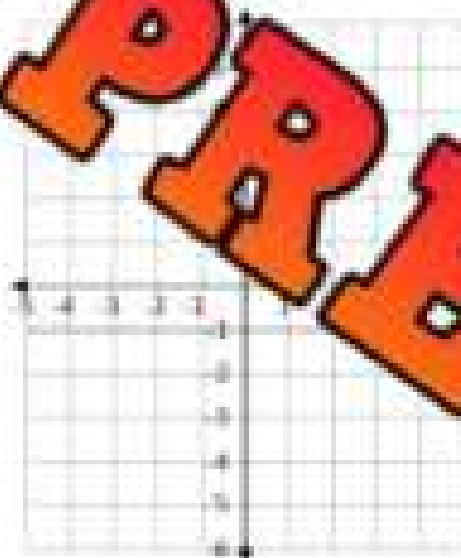

2) $y = 3x - 6$

x	0	1	2	3	4
y					

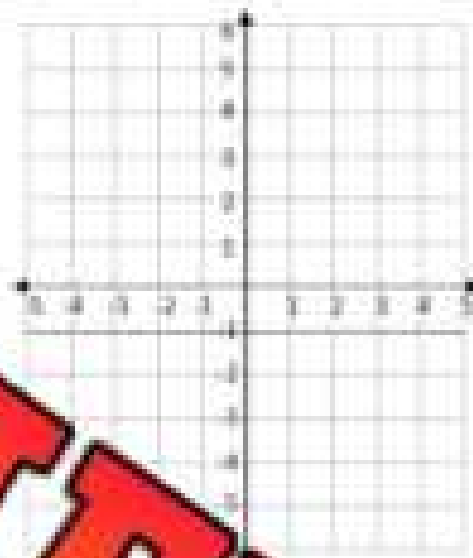

3) $y = -x + 2$

x	0	1	2	3	4
y					

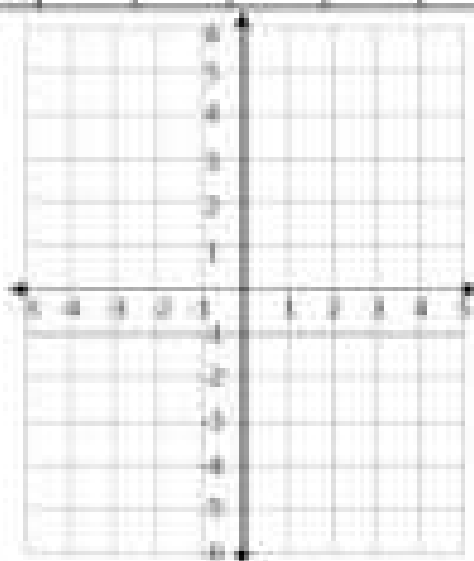

x	0	1	2	3	4
y					

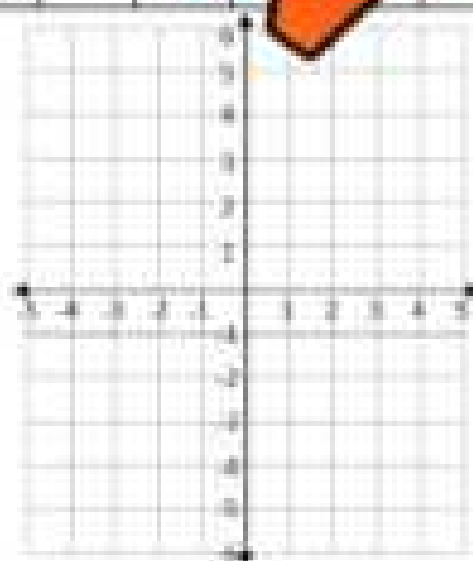

PREVIEW

Linear Equations – Graphing 2 Variables

Instructions

Graph the equations below. Create a table of values if necessary.

1) $y = 3x - 4$

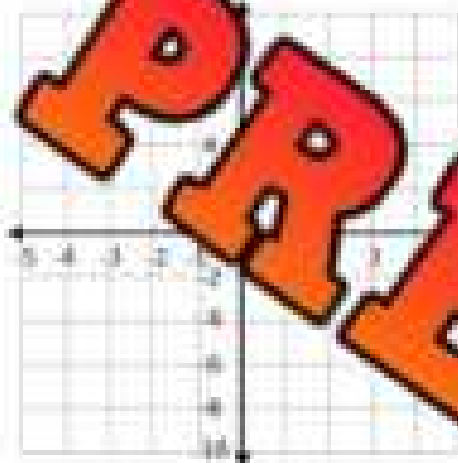

2) $y = -4x + 10$

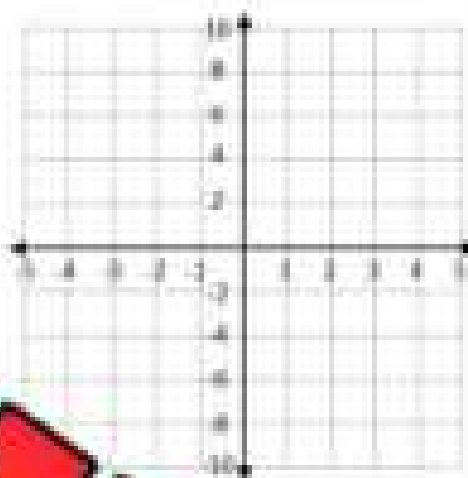

3) $y = -3x + 8$

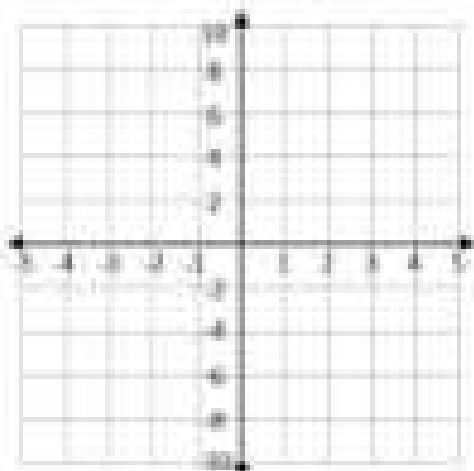

4) $y = 4$

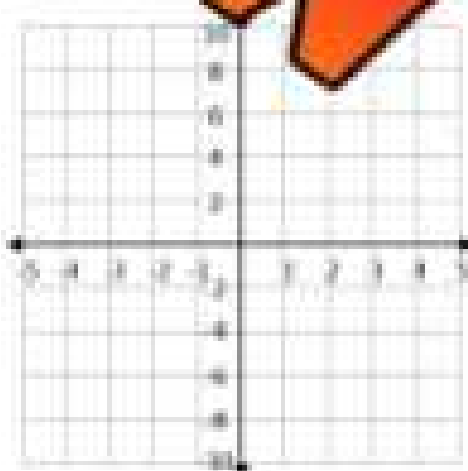

PREVIEW

Exit Cards

Cut Out

Cut out the exit cards below and have students complete them at the end of class.

Name: _____

Graph the equations below.

$$y = -6x + 4$$

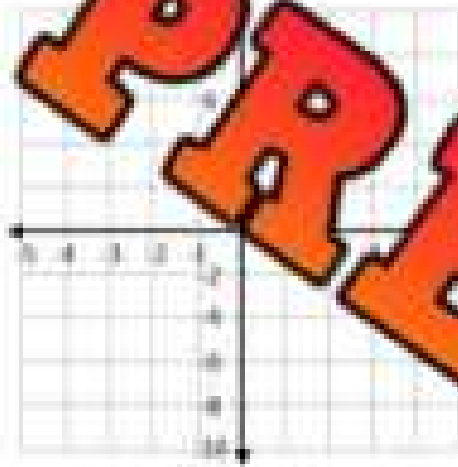

Name: _____

Graph the equations below.

$$y = -6x + 4$$

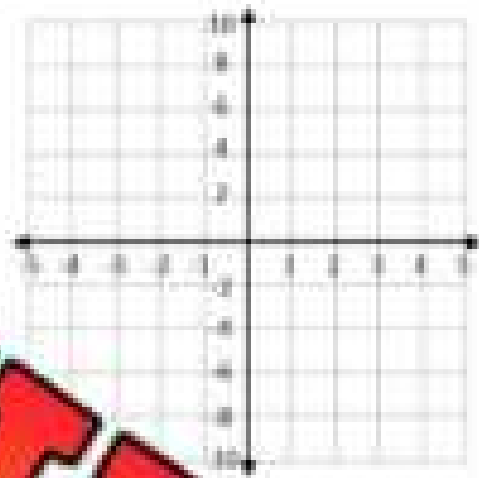

Name: _____

Graph the equations below.

$$y = -6x + 4$$

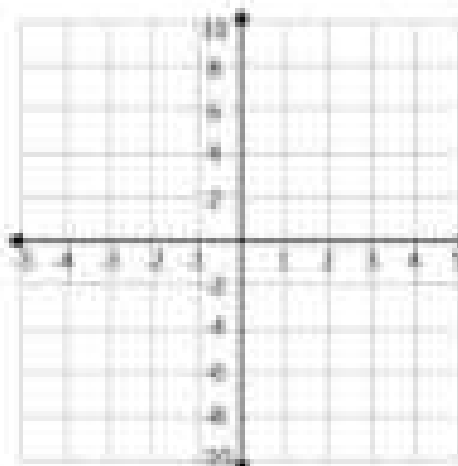

Name: _____

Graph the equations below.

$$y = -6x + 4$$

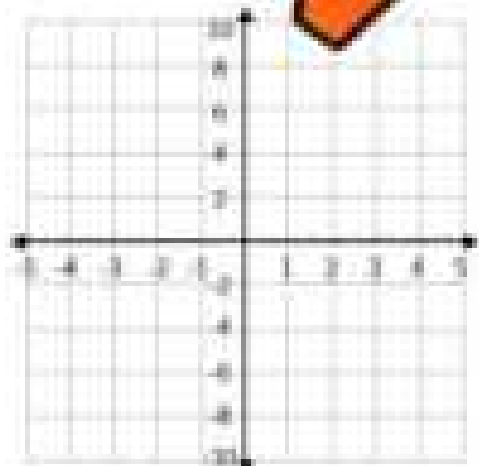

PREVIEW

Linear Equations – Graphing 2 Variables

Instructions

Fill in the table of values and then graph the results using ordered pairs.

Matt is hosting a pizza party. He will buy 2 slices for each person coming and 4 extra slices in case someone shows up unexpectedly. He determined an equation that will help him decide how many slices to buy: $y = 2x + 4$

a) Fill in the table of values using the equation above.

x	1	2	3	4	5	6
y						

b) Represent the data on the graph. Connect the dots using a line. Is the relation linear? Explain.

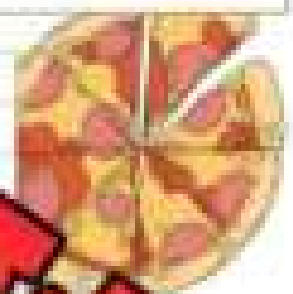
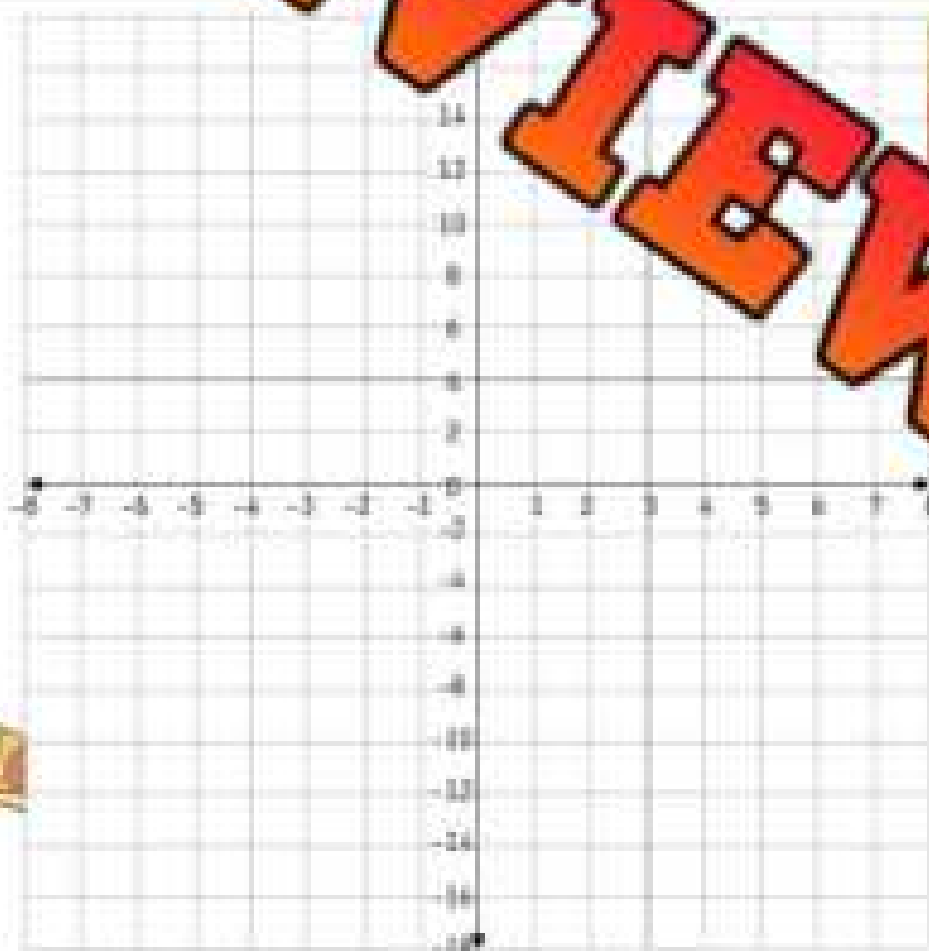

Linear Equations – Graphing 2 Variables

Instructions

Fill in the table of values and then graph the results using ordered pairs.

Hadley sells her homemade scarfs at a flea market. It costs her \$10 to rent a table but she makes \$5 each hour she is there. She uses the following equation to represent her earnings; $y = 5x - 10$

a) Fill in the table of values using the equation above.

x	2	3	4	5	6	7	8

b) Represent the results on the graph. Connect the dots using a line.

c) Fill in the missing ordered pairs below

(10, ____), (20, ____), (____, 80), (____, 100), (____, 150)

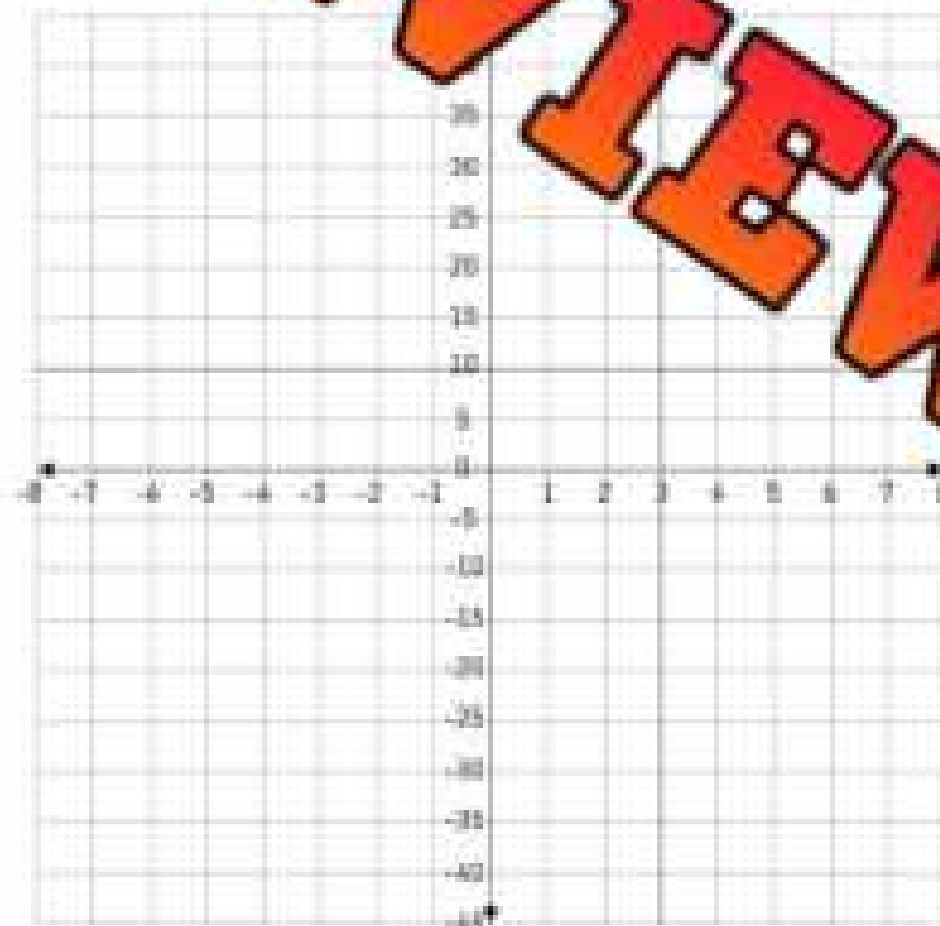

Linear Inequalities – Boundary Line

When we graph an inequality on a cartesian plane, we use a dashed line or a solid line depending if the inequality is greater/less than or greater/less than or equal to.

Greater/less than or equal to \leq / \geq

Greater/less than $<$ / $>$

Part 1 Fill in the table below. Do the inequalities require a dashed or solid boundary line?

Inequality	Dashed or Solid Boundary Line?
1) $x < 9$	
2) $y \geq 5$	
3) $12 - (-4) \geq x$	
4) $y - 7 \geq 15$	
5) $y > 6 + 16$	

If the inequality uses a greater than or equal to sign, we shade above the line. When we have a less than or equal sign, we shade below the line.

Part 2 Fill in the table below.

Inequality	Dashed or Solid Boundary Line?	Shade Above or Below
1) $x \geq 9$		
2) $y < 5$		
3) $12 - (-4) \geq x$		
4) $9 + x \leq 25$		
5) $15 - y < 25 + 3$		
6) $x + 12 - 6 > 29$		
7) $8 + 6 - y < 31 + 5$		
8) $y - 5 \geq 11 + 6 - 8$		

Linear Inequalities – Boundary Line

Questions

Fill in the table below.

	Inequality	Simplify (if necessary)	Dashed or Solid Line	Shade Above or Below
1)	15			
2)	$4 < ($			
3)	$13 > 2$			
4)	$11 + x \geq 15 \times 2$			
5)	$9 + (-5) > y + 9$			
6)	$8 < 32x$			
7)	$5 + y \geq \frac{48}{-6}$			
8)	$7 > \frac{56}{7} + y$			
9)	$y \geq 25 + \frac{-48}{12}$			
10)	$13 - 5 < -2x$			

PREVIEW

Linear Inequalities – Order Paris

Questions

Circle whether the ordered pair is a solution of the graph.

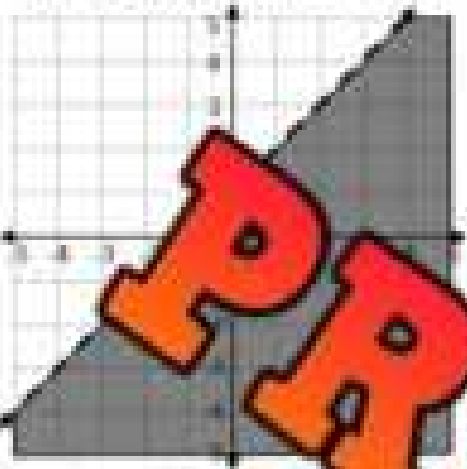
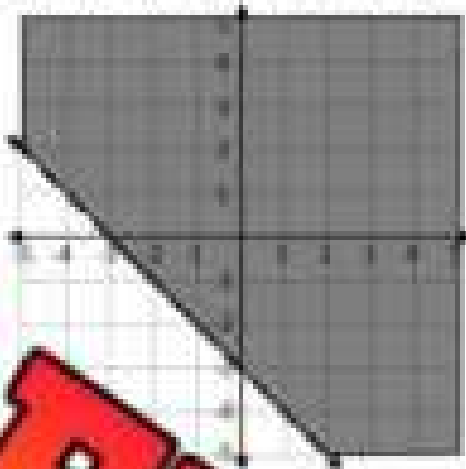
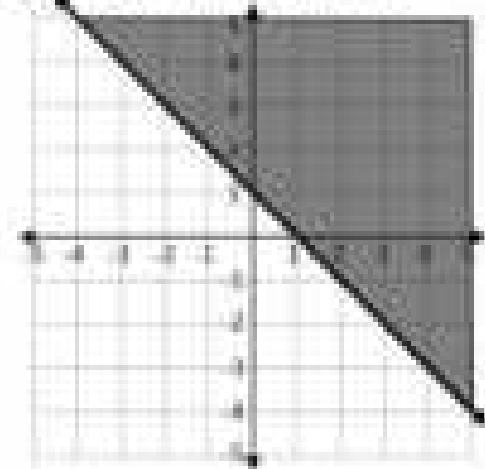
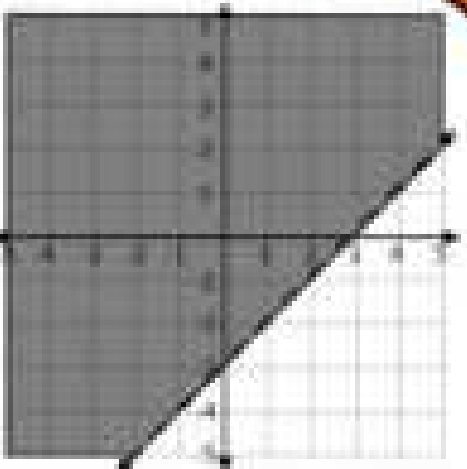
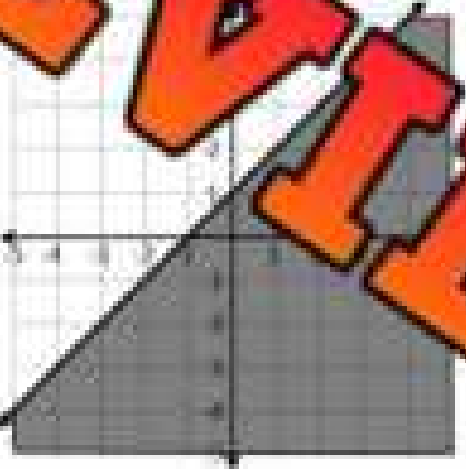
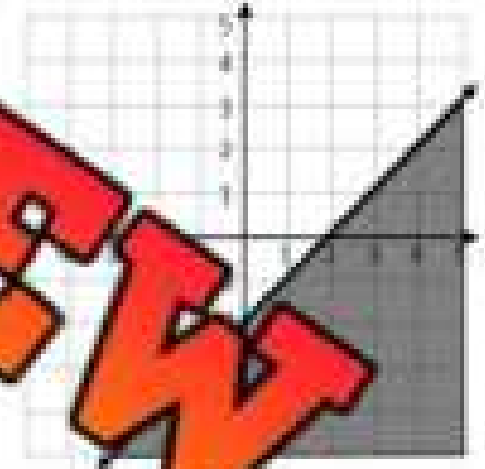
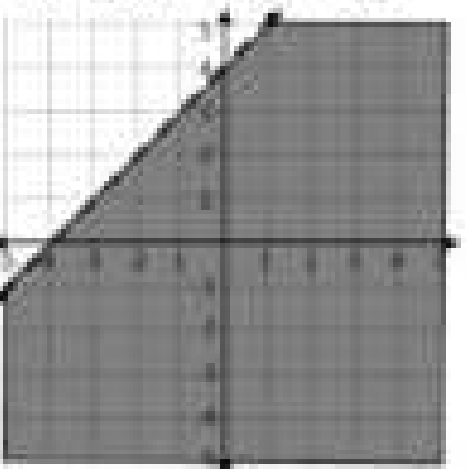
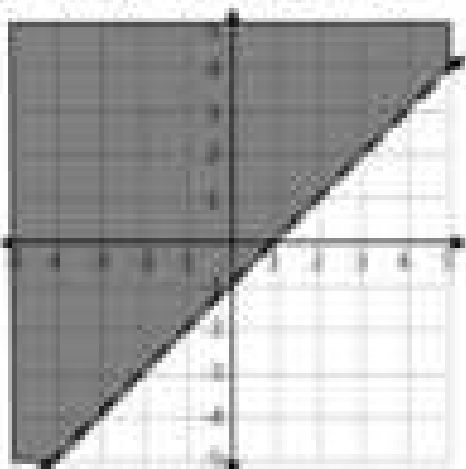
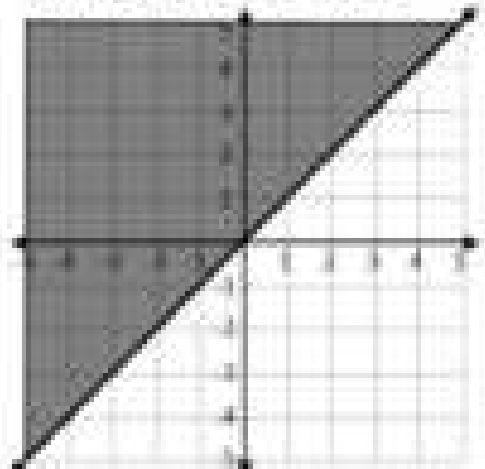
 1) $(-3, 2)$ Yes No

 2) $(-4, -2)$ Yes No

 3) $(3, 4)$ Yes No

 4) $(-5, -5)$ Yes No

 5) $(2, 4)$ Yes No

 6) $(-3, 0)$ Yes No

 7) $(0, 4)$ Yes No

 8) $(-2, -4)$ Yes No

 9) $(0, 0)$ Yes No

Graphing Inequalities – Two Variables

Questions

Fill in the table of values and then graph inequalities.

1) $y > -2x - 2$

x	0	1	2	3	4
y					

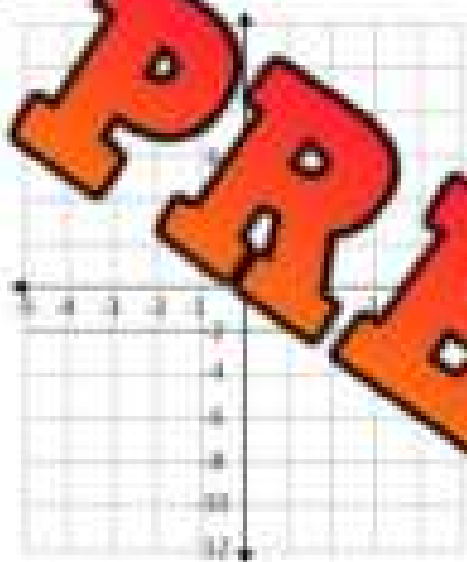

2) $y < -x + 4$

x	0	1	2	3	4
y					

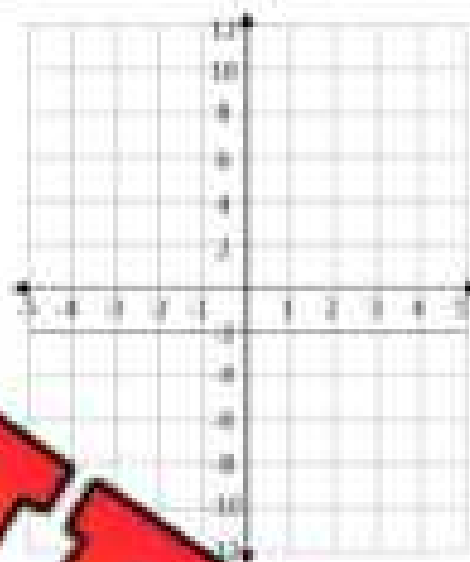

3) $y \geq -3x + 4$

x	0	1	2	3	4
y					

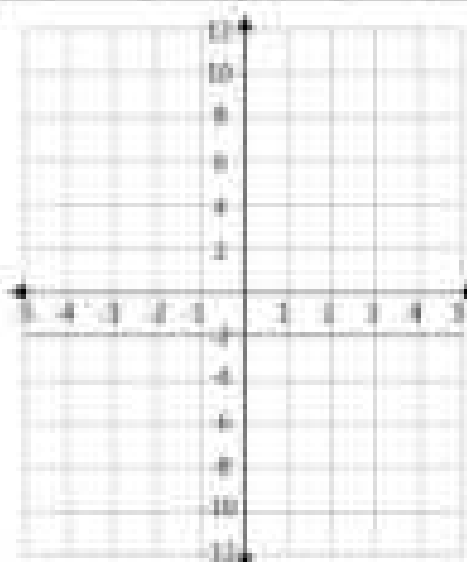

x	0	1	2	3	4
y					

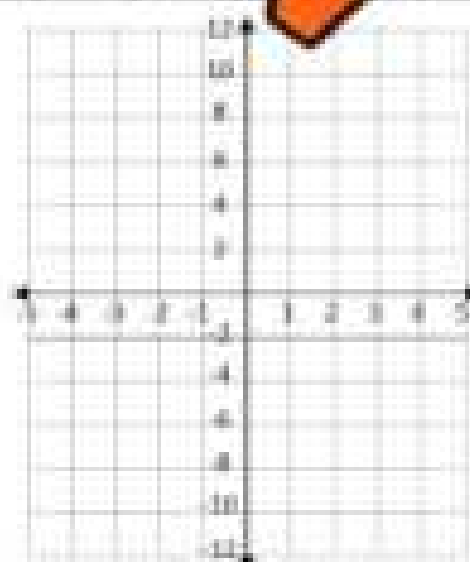

Rise Over Run - Slope

The **slope** of a line is how steep the line is. We can determine the slope of a line by remembering 'rise over run'.

Rise
Run

In the example to the right, we can see the rise is 2, and the run is 1. This means our slope is $\frac{2}{1}$ or 2.

If a line increases from left to right, it is positive.
If it decreases from left to right, it is negative.

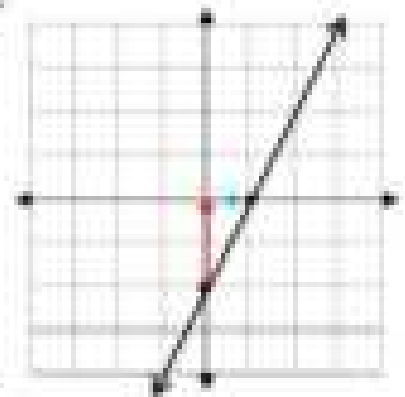

Question What is the slope of each line? Use arrows to label the rise and run.

1

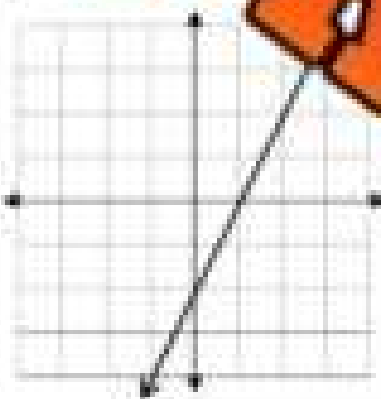

2

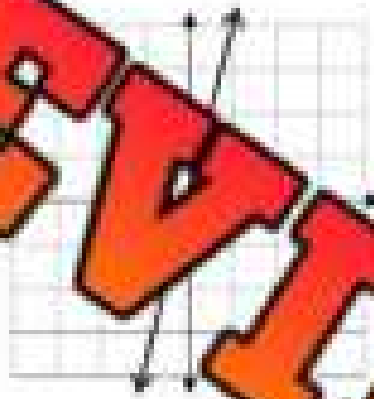

3

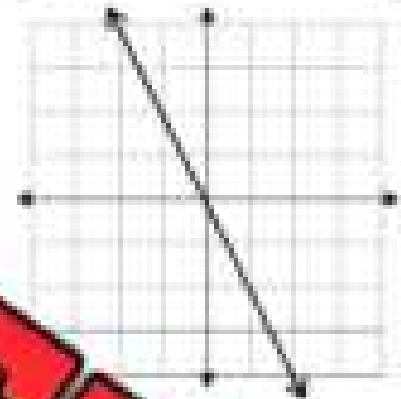

4

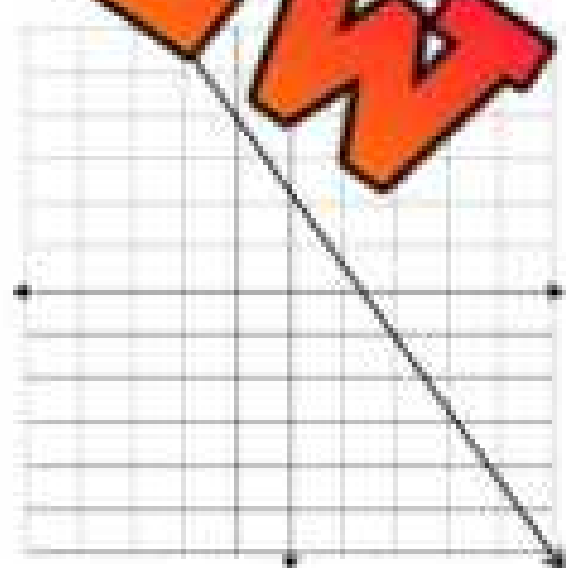
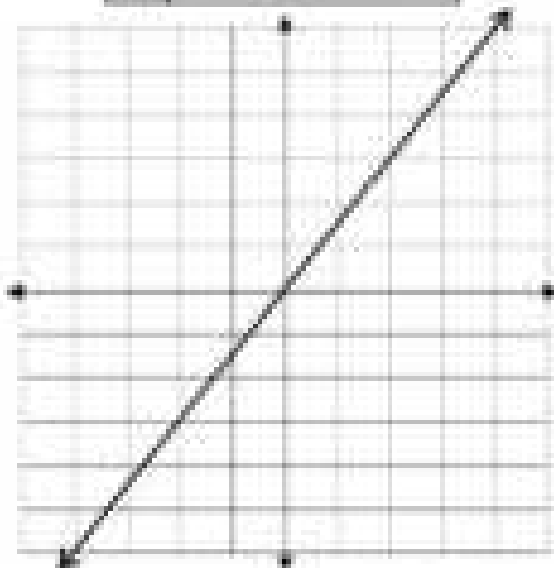

6) Write 4 ordered pairs from question 5.

Graphing Inequalities – Two Variables

Example - $y > 2x - 2$

The slope is 2 and the constant is -2.

Steps:

- 1) The y-intercept is -2. Plot a dot on the y-axis at -2.
- 2) The slope is 2. Go up 2 and right 1.
- 3) Plot the next coordinates going up 2 and right 1.
- 4) Once you have 3 coordinates plotted, you can draw your line up. Dashes if $>$ or $<$ and solid if \geq or \leq .



Question: Graph the inequalities on the cartesian planes below:

1) $y \geq x - 3$

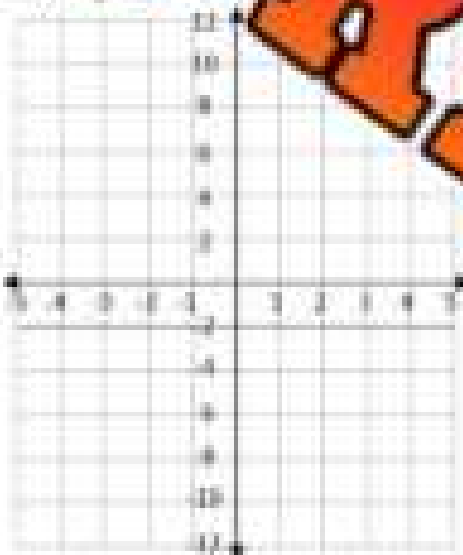

2) $y < 2x + 4$

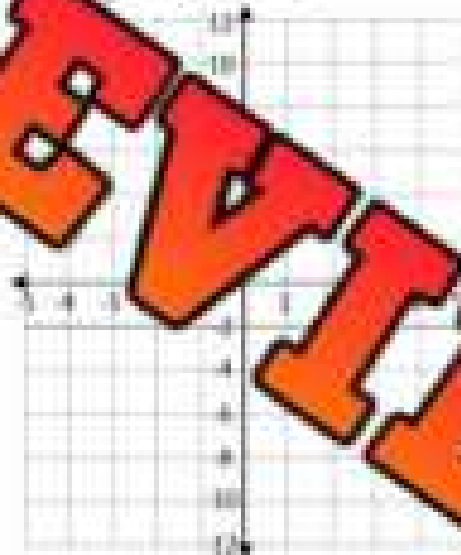

3) $y \geq 3x - 2$

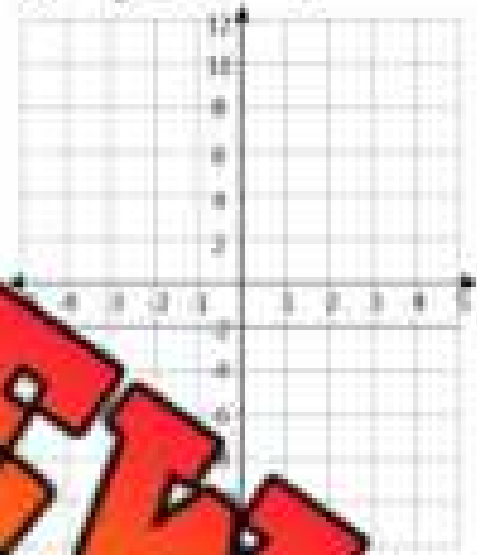

4) $y > -2x - 2$

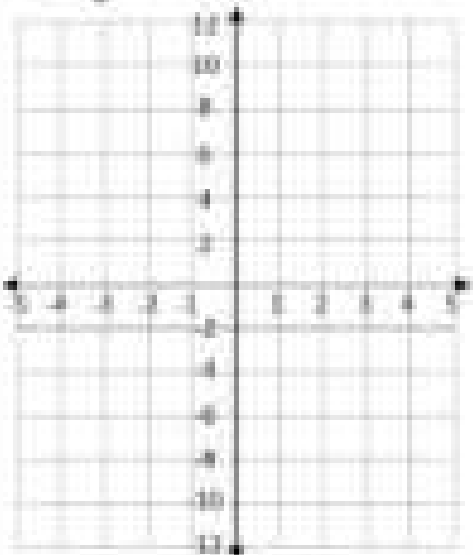

5) $y > -x + 5$

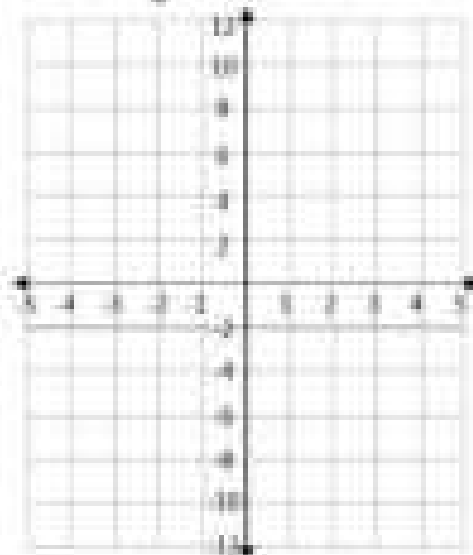

6) $y < x - 6$

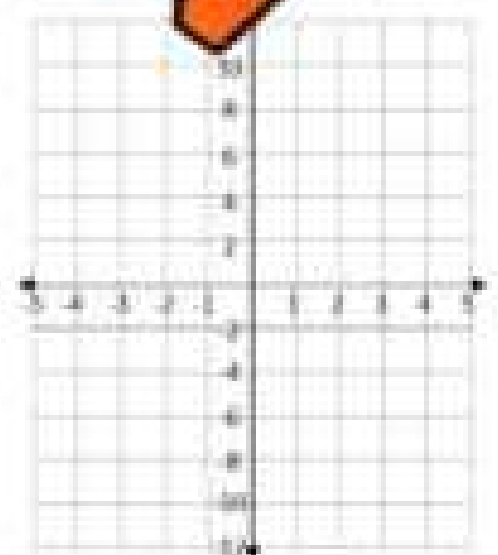

Algebra Quiz - Equations

Part 1

Solve

1) $8n + 4n$ = _____ n	2) $11p + 7p$ = _____ p	3) $(-25c) + 33c$ = _____ c
4) $15n + 32n + 11p + 36p$ = _____ n + _____ p	5) $12p - 4p$ = _____ p	6) $15s + r - 14s - 13r$ = _____ s + _____ r
7) _____	8) $12n - 43c - 33n + 21c$ = _____ c	9) $42n + y - 13y - 23c + 66c$ = _____ n + _____ c + _____ y

Part 2

Write the letter of the equivalent expression from column 1.

Answer	Column 1	Letter	Column 2
	$5(7 - t)$		$5t + 35$
	$-5(7 + t)$		$5t$
	$5(t + 7)$	c	35
	$-5(t - 7)$	d	

Part 3

Add and subtract the binomials below.

1) $(8y + 9) + (5y + 6)$	2) $(11m - 14y) - (y - 4m)$
3) $(32y - 16u) - (14u + 18y)$	4) $(22y - 15u) + (7u - 15y)$

Part 4

Evaluate the following expressions for $x = 5$ and $p = -7$

1) $(x) + (p) - 11$	2) $17 + x + (p)$	3) $(19 - x) - (p)$	4) $x + (26 + p)$
5) $54 + (p + 5x)$	6) $22 + 8x - (p + 5)$	7) $12 - \frac{7x}{p} + 5p$	8) $9x + (2p - x)$

Part 5

Find out if each equation has an equal sign (=) if it is not balanced.

1) $(-9) + 7 = 2$	2) $13 + 13 = -5$	3) $(-21) + 13 = -8$
4) $\frac{50}{10} = -10$	5) $21 + 9 = (-4)$	6) $\frac{48}{-8} = 6$

Part 6

Find out the value of the variables.

1) $12 + n = 23$ $n =$	2) $n + 15 = 29$ $n =$	3) $12 + 12 = 24$ $n =$
4) $12.5 - 3.1 = p$ $p =$	5) $9.2 - p = 6.4$ $p =$	6) $-3.5 + r = -7.8$ $r =$
7) $(-3n) = (-18)$ $n =$	8) $6n = (-62)$ $n =$	9) $\frac{n}{8} = -9$ $n =$

Part 7

Find out the value of the variables using BEDMAS.

1) $9 + (4 \times 5) = n$	2) $31 - (7 \times p) = 10$	3) $(9 \times 6) + (12 + n) = 58$
4) $n + (32 + 8) = 12$	5) $5(2 + p) = 45$	6) $9n = 2 \times 27$

Part 8

Write equations for the situations below and answer the questions.

- 1) Parker takes some candies from his house before leaving to go trick-or-treating on Halloween. He visits 10 houses and takes more candies at the houses in his neighbourhood. If he trips and drops all his candies at the end of the night, he will have 90 candies. How many candies did he take from his house?

- a) Write an equation that represents the problem.
- b) How many candies did he take from his house?



- 2) A group of 8 friends went to an amusement park. Tickets to enter the park cost \$9. Each friend purchased the all-inclusive pass that allowed them to go on as many rides as they wanted to. In total, the 8 friends paid \$176 for the ticket and all-inclusive pass.

- a) Write an equation that represents the problem.
- b) How much did the all-inclusive pass cost?



Part 9

Graph the inequalities on the number line.

1) $4 + x > 12$



2) $17 - x \leq 9$



Part 10

Simplify the inequalities below. Make sure the variable is on the left.

5

2) $x \leq 24 + 6 \times (-5)$

3) $48 < x$

4) $x + (3 \times 4) \leq 60 + (-10)$

Part 11

Fill in the table of values and then graph the

1) $y > -x + 2$

x	0	1	2	3	4
y					

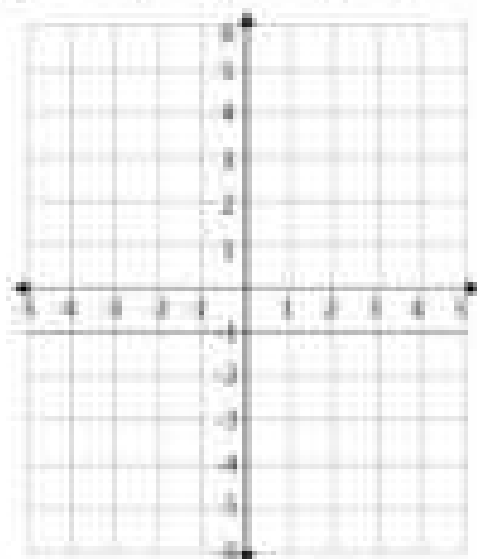

6

x	1	2	3	4
y				

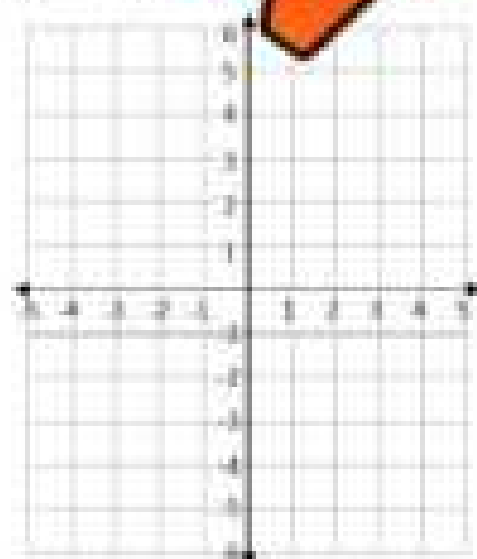

Grade 7 C3. Coding

	Curriculum Expectations	Pages That Cover the Expectations
C3.1	solve problems and create computational representations of mathematical situations by writing and executing code, including code that involves the analysis of data in order to inform and communicate decisions	190 - 193, 195 - 201, 203 - 205, 207 - 214
C3.2	read and alter existing code involving the analysis of data in order to inform and communicate decisions, and describe how changes to the code affect the outcomes and the efficiency of the code	191, 194, 202 - 206

Writing Code - Loops

Writing Code - Code Bank

- go right (# of spaces)
- go left (# of spaces)
- go down (# of spaces)
- go up (# of spaces)
- loop ___ times

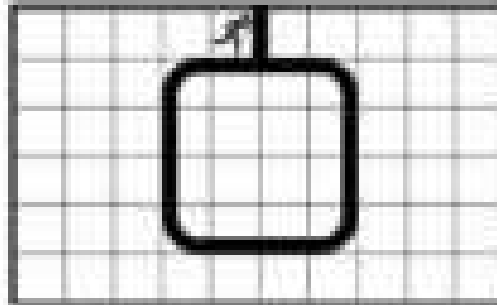

Example

- loop 5 times
- go right 3
- go down 3
- go left 5
- go up 3
- go right 2
- go right 1

Question: Write code that sends the runner around the track.

- Use a loop to send the runner around the track 7 times. (Don't forget to cross the finish line!)

Line 1: _____

Line 2: _____

Line 3: _____

Line 4: _____

Line 5: _____

Line 6: _____

Line 7: _____

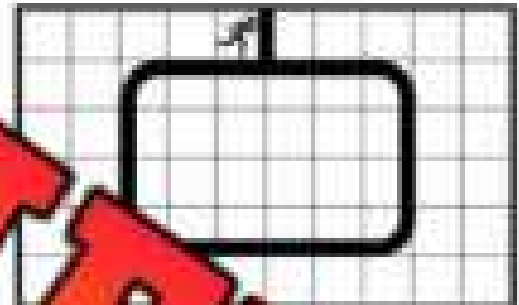

- Use a loop to send the runner around the track 5 times. (Don't forget to cross the finish line!)

Line 1: _____

Line 2: _____

Line 3: _____

Line 4: _____

Line 5: _____

Line 6: _____

Line 7: _____

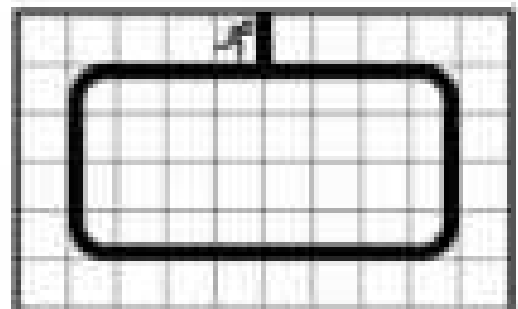

PREVIEW

Introduction to If/Then Statements

An if/then statement is a conditional that is an action that could occur if something specific happens.

For example - If the bell goes at school, then the students go to class.



Questions

Fill in the If/Then Statements with outcomes that make sense.

1)	If _____ into the _____	then _____
2)	If they _____	then _____
3)	If player 1 pushes _____	then _____
4)	If a key is pushed on a piano,	then _____
5)	If you answer correctly,	then _____
6)	If the song ends,	then _____
7)	If user presses the shuffle song button,	then _____
8)	If player 1 has more points than player 2 at the end of the game,	then _____
9)	If the password entered is incorrect,	then _____
10)	If the play button is pushed,	then _____

If Statements – Conditional Coding

An if statement allows a code to be run if an event has happened. If the event does not happen, the code is not run. All interactive games use if statements. For example, when a game has a button in it, the button will have an if code. This means that if the button is pushed, then a code will run that causes something to happen.

Example Code - If player gets 50 points, then print "Great Job!"



Question Write the answer to the question and then run the code.

Written	The Computer Prints...
If answer is ≥ 10 , then print "Great job!" If answer is < 90 , then print "Better luck next time!" run $5 \times 12 + 32$	
If y is < 150 , then print "Better luck next time!" If y is ≥ 150 , then print "Wow, great job!" run $y = 6 \times 15 + 55$	
If player has ≥ 500 points (p), then print "You win!" If player has < 500 points (p), then print "You lose!" run $p = 100 + 2^2 \times 10 \times 2 - 10$	
If student mark (m) is $\geq 80\%$, then print "Genius!" If student mark (m) is $< 80\%$, then print "Good effort!" run $m = 21/25$	
If student mark (m) is $\geq 50\%$, then print "You passed!" If student mark (m) is $< 50\%$, then print "You failed!" run $m = \frac{8 + 9 + 8}{50}$	

If Statements – Dice Game

The object of the game is to get as many points as you can. Follow the if/then statements to get points.

Instructions

1. Start at question 1. Read the if/then statement to get points
2. Go through all 10 questions and add up your points at the end

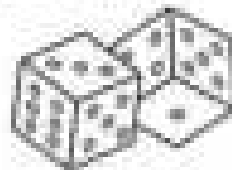

Questions Use a dice to play the game below. Follow the if/then codes.

If/Then Code	Point Total
1) If you roll an even number, then you get +10 points If you roll an odd number, then you get -10 points	
2) If you roll a 6, then you get +5 points If you don't roll a 6, then you get 0 points	
3) If you roll a 3 or 4, then you get +7 points If you don't roll a 3 or 4, then you get -10 points	
4) If you roll a 2, then you start over at 0 points If you roll any other number, then you get +5 points	
5) If you roll 3 or less, then you get +10 points If you roll 4 or more, then you get -10 points	
6) If you roll a 1 or 6, then you get +15 points If you don't roll a 1 or 6, then you get -5 points	
7) If you roll 2 or more, then you get +5 points If you roll a 1, then you get -20 points	
8) If you roll an odd number, then you get +10 points If you roll an even number, then you get -10 points	
9) If you roll a 3, then you get +20 points If you don't roll a 3, then you get 0 points	
10) If you roll a 5 or less, then you get +10 points If you roll a 6, then you get -25 points	

If Statements – Dice Game

The object of the game is to get as many points as you can. Follow the if/then statements and solve any equation from the list you are sent to. Cross out the equation once you have used it because you can only use each equation once. You earn the answer from the equation as points. Record your points in the column on the right.

Instructions

Follow the if/then codes to solve equations and earn points.



If/Then Code	Points
1) If you roll a 1, then solve an equation from list 1. If you roll a 2, then solve an equation from list 2.	
2) If you roll a 3, then solve an equation from list 3. If you roll a 4, then solve an equation from list 4.	
3) If you roll a 5, then solve an equation from list 3. If you roll a number other than 5, then solve an equation from list 2.	
4) If you roll an even number, then solve an equation from list 5. If you roll an odd number, then solve an equation from list 6.	
5) If you roll a 1 or a 6, then solve an equation from list 1. If you roll a 2, 3, 4, or 5, then solve an equation from list 2.	
6) If you roll a 2 or 5, then solve an equation from list 1. If you roll a 1, 3, 4, or 6, then solve an equation from list 2.	
7) If you roll a 3 or 4, then solve an equation from list 5. If you roll a 1, 2, 5, or 6, then solve an equation from list 1.	
8) If you roll a 6, then solve an equation from any list. If you roll a 1, 2, 3, 4, or 5, then solve an equation from list 1.	
9) If you roll a 1 then solve an equation from any list. If you roll a 2, 3, 4, 5, or 6, then solve an equation from list 1.	
Total Points	

List 1	List 2	List 3	List 4	List 5	List 6
$5 = 5$	$15 = 5$	3×2	$25 + 5$	$12 + 12$	3×3
$12 + 6$	$14 - 6$	7×5	$30 + 10$	$23 + 5$	4×6
$13 + 8$	$40 - 32$	3×6	$20 + 4$	$15 + 13$	7×3
$21 + 13$	$32 - 21$	4×5	$12 + 2$	$41 - 13$	$60 + 4$
$14 + 22$	$45 - 15$	9×4	$15 + 3$	$50 - 10$	$48 + 8$
$38 + 20$	$50 - 21$	6×6	$36 + 6$	$40 - 15$	$9 + 3$

Using Programs to Analyze Data - Basketball

Directions

Use the data to program Curry's shooting from last game.

Steph Curry is a tremendous shooter. His shot attempts and shot makes from his last game have been displayed in the table below. The coordinates for each shot show where Curry made or missed from.

Program

```

if the shot is (made)
then plot a green dot using the coordinates
if the shot is (missed)
then plot a red dot
  
```

Shot	Shot
(3, 9)	(-1, 11)
(-5, 10)	(-3, 13)
(1, 8)	(5, 10)
(-10, 18)	(-8, 17)
(-1, 18)	(6, 10)
(4, 1)	(-8, 12)
(2, 15)	(9, 15)
(-8, 11)	(8, 14)
(-2, 15)	
(1, 18)	

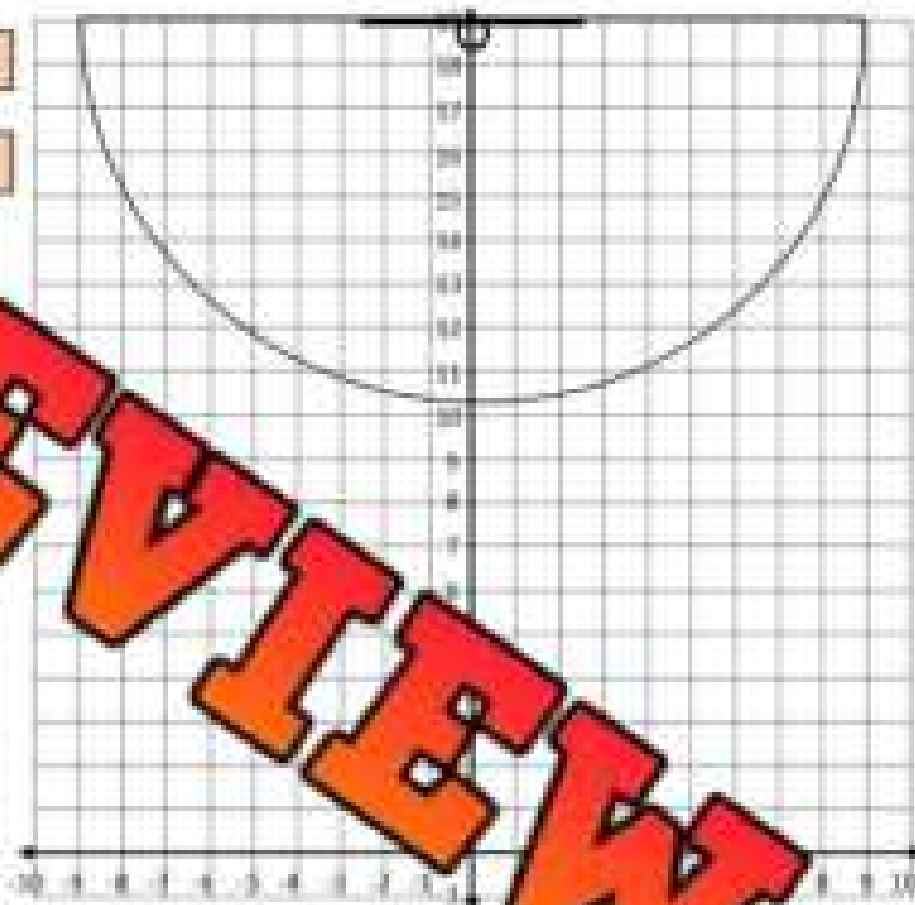

Questions

Answer the questions below.

Questions	Answers
1) What was Curry's field goal percentage? (#Makes/#Total Shots)	
2) What was Curry's 3-point percentage? (#3-Point Makes/#Total 3-Point Shots)	
3) How many points did Curry have?	
4) Curry has asked you where he should shoot from. Use the data from the program to give him at least 2 tips.	

Using Programs to Analyze Data - Baseball

Directions

Use the data to program Gausman's shooting from last game.

Kevin Gausman pitches for the Blue Jays. He only pitched 3 innings last game. His strikes and pitches that resulted in a hit are recorded in the table. Where he threw each pitch has been displayed using coordinates.

Program

if the pitch is a strike

then plot a graph using the coordinates

if the pitch is a hit

then plot a graph using the coordinates

Strike	Hit
(-3, 6)	
(-4, -6)	(2, 2)
(5, -5)	
(3, 6)	(-2, 2)
(-7, 6)	(2, -1)
(6, 6)	(-3, -2)
(-5, -4)	(3, -2)
(-8, -4)	(-2, -3)
(5, 5)	(2, -2)
(-3, 5)	

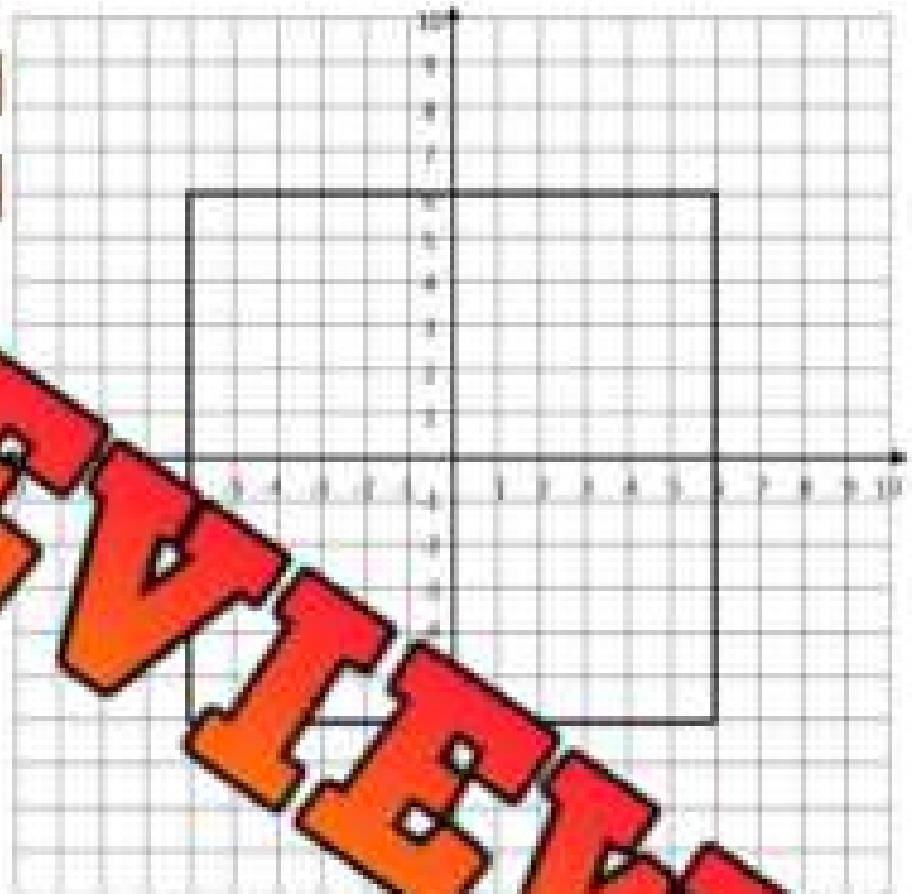

Questions

Answer the questions below.

Questions	Answers
1) How many strikes did Gausman throw?	
2) How many hits did he give up?	
3) How many pitches did he make in the upper part of the strike zone?	
4) How many strikes did Gausman throw out of the strike zone?	
5) Gausman has asked you where he should throw his pitches. Use the data from the program to give him at least 2 tips.	

Analyze Data – Rock, Paper, Scissors

Directions

Follow the program code to analyze patterns in Rock, Paper, Scissors.

When we play rock, paper, scissors, we unintentionally follow patterns that can be used against us. Creating a program that collects data can help us find patterns that could be useful in determining which option our opponent will use next.

Directions

- 1) Play 20 rounds of rock paper scissors with your opponent.
- 2) Enter the choice for each round.
- 3) Use the data to determine which option to play next.

loop 20 times

if opponent shows rock

then place a checkmark in rock column

loop 20 times

if opponent shows paper

then place a checkmark in paper column

loop 20 times

if opponent shows scissors

then place a checkmark in scissors column

Round	Rock	Paper	Scissors
1			
2			
3			
4			
5			
6			
7			
8			
9			
10			
11			
12			
13			
14			
15			
16			
17			
18			
19			
20			

Questions

Answer the questions below.

1) Describe a pattern you found in your opponent's choice during the game.

2) Based on the way the game ended, which option do you think your opponent will play next?

3) If a computer program automated this data collection, how would it help you in winning rock, paper, scissors?

Using Subprograms in Coding

A **subprogram** is a small set of instructions that does one specific job. You can reuse it whenever you need that job done again. It helps keep your code neat and saves time.

For example, if you're programming a robot to turn around, you could make a subprogram called **TurnAround**. Then, instead of writing the turn steps every time, you just call **TurnAround** whenever the robot needs to spin.

Use subprograms to write efficient code that gets the robot to pick up the instructions and return them to the toy bin. The robot can only handle one toy at a time. There may be more than one toy at each location (x2, x3, etc.).



1) Pick up 2 guitars and 3 drums and return them to the toy bin.

Name _____

208

Learning Activities
111

2) Pick up 2 cars, 4 dice, and 2 yo-yos and return them to the toy bin.

3) Pick up all the equipment in the room (including the trophies) and return them to the toy bin.

4) Pick up all the remaining things in the room and return them to the toy bin.

PREVIEW

Using Subprograms in Coding

In this activity, you'll write a simple program that:

- Collects data about heartbeats and time (in minutes)
- Plots that data as coordinate points
- Calculates the average number of heartbeats per minute using a subprogram

You will record your heart rate each minute for 10 minutes. Then you'll write a program with subprograms to collect this data and translate it onto a graph.

How-To-Do It Follow the guide below to write your computer program.

Step	What to Do	Suggestions / Hints
1	Create a subprogram that plots each point on a graph.	Use inputs like <code>numBeats</code> and <code>numMinutes</code> . Call your subprogram something like <code>plotPoints</code> . Plot <code>(minutes, beats)</code> .
2	Create a subprogram that calculates the average beats per minute.	Use <code>totalBeatsPerMinute</code> as an input. Divide the total by 10. You could call your subprogram <code>calcAvgBeatsPerMinute</code> .
3	In the main program, set up a loop to repeat 10 times.	Use a <code>repeat</code> command or <code>loop</code> command to collect data 10 times.
4	Inside the loop, ask the user to input two values.	Ask for beats and minutes. Store them in variables like <code>numBeats</code> and <code>numMinutes</code> .
5	Run the point-plotting subprogram each time.	Call your <code>plotPoints</code> subprogram inside the loop.
6	Keep track of the total beats per minute as the loop runs.	Each time, calculate <code>numBeats / numMinutes</code> and add it to a total variable (e.g. <code>totalBeatsPerMinute</code>). You can then divide it by 10 as this was done over 10 minutes.
7	After the loop, run the average calculation subprogram.	This should calculate the average from the total. Use your <code>calcAvgBeatsPerMinute</code> subprogram here.
8	Display the average beats per minute.	Use an output command. Show something like: "The average heartbeat per minute is" followed by your answer.

Instructions

Collect your heart rate every minute for 10 minutes. Record it below and graph it after you finish writing your code.

Minutes	Heart Rate
1	
2	
3	
4	
5	

Minutes	Heart Rate
6	
7	
8	
9	
10	

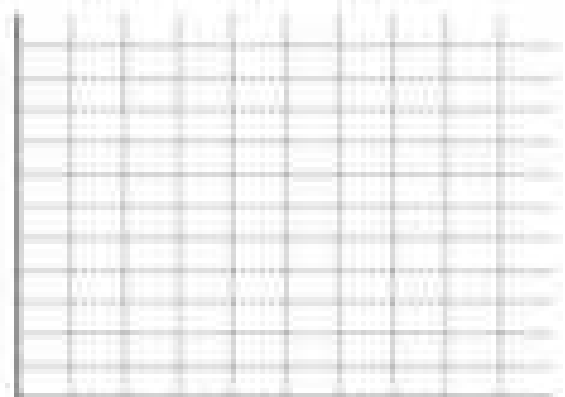

Instructions

Draw a picture below in the blank space.

PREVIEW

Using Subprograms in Coding

In this activity, you're going to create a program that calculates how much a group will pay for concert tickets. You'll ask the user to enter how many people are going, how much each ticket costs, and then use subprograms to calculate the total price, apply tax, and display the final amount.

How-To-Guide

Follow the guide below to write your computer program.

Step	What to Do	Suggestions / Hints
1	Create a subprogram that calculates the total price before tax.	This should multiply two values the user provides. Think about what those values represent.
2	Create a subprogram that applies a tax to the total.	The tax rate for Ontario is 13%.
3	Ask the user to input two different values related to the purchase.	Think about what information you would need if you were buying tickets for a group.
4	Use the first subprogram to calculate the total based on user input.	Store the result in a variable.
5	Use the second subprogram to apply tax to the total.	The new result should represent the amount the user needs to pay.
6	Display the final result to the user in a clear message.	Include helpful wording so the user understands what the total means.
7	Test your program with different numbers to check if it works.	Try it with small and large values to make sure the logic still makes sense.
8	Review your subprograms to make sure they're reusable and named clearly.	Could you use them again in a different situation, like buying snacks or shirts?

Name _____

212

Getting Started
11

Instructions

Write your code below in the blank space.

PREVIEW

Test

Test your program by explaining what would happen at each step of the program using values you make up - # of tickets, cost, total cost, with tax.

Unit Test - Coding

Part 1

Write code that sends the runner around the track.

Use a loop to send the runner 5400 metres.

Line 1: _____

Line 2: _____

Line 3: _____

Line 4: _____

Line 5: _____

Line 6: _____

Line 7: _____

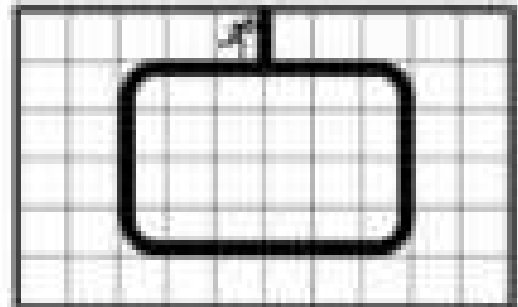

1 lap = 450 metres

Part 2

Write what the computer will display based on the code written.

Code Written	The Computer Replies	Code Written	The Computer Replies
$y = 45$ $x + y = 92$ <code>print (x)</code>	_ _	$3y = 15$ <code>print (y)</code>	_ _
$x = 150$ $x + y = 11 - 5$ <code>print (y)</code>	_ _	$x = 68$ $x + y = 20 + 32$ <code>print (y)</code>	_ _

Part 3

Calculate the answer to the question and then run the code.

Code Written	The Computer Prints..
If student mark (w) is $\geq 50\%$, then print "You passed" If student mark (w) is $< 50\%$, then print "You failed" run $w = \frac{15 + 15 + 12}{3}$	
If player has > 50 points (p), then print "You win" If player has < 50 points (p), then print "You lose" run $p = 15 \times 3 - (-10)$	

Directions

Use the data to program Ronaldo's shots on goal.

Cristiano Ronaldo is a professional soccer player. His shots on goal that were saved and his shots on goal that went in for his last 10 games are displayed in the table below. The coordinates show where his shots were aimed.

Program

if the shot is scored
then plot a green dot using the coordinates
if the shot is saved
then plot a red dot using the coordinates

Shots Scored	Shots Saved
(7, 11)	(-4, 5)
(6, 1)	(4, 5)
(-7, 1)	(0, 4)
(-5, 11)	(5, 7)
(7, 1)	(-4, 5)
(-6, 10)	(2, 2)

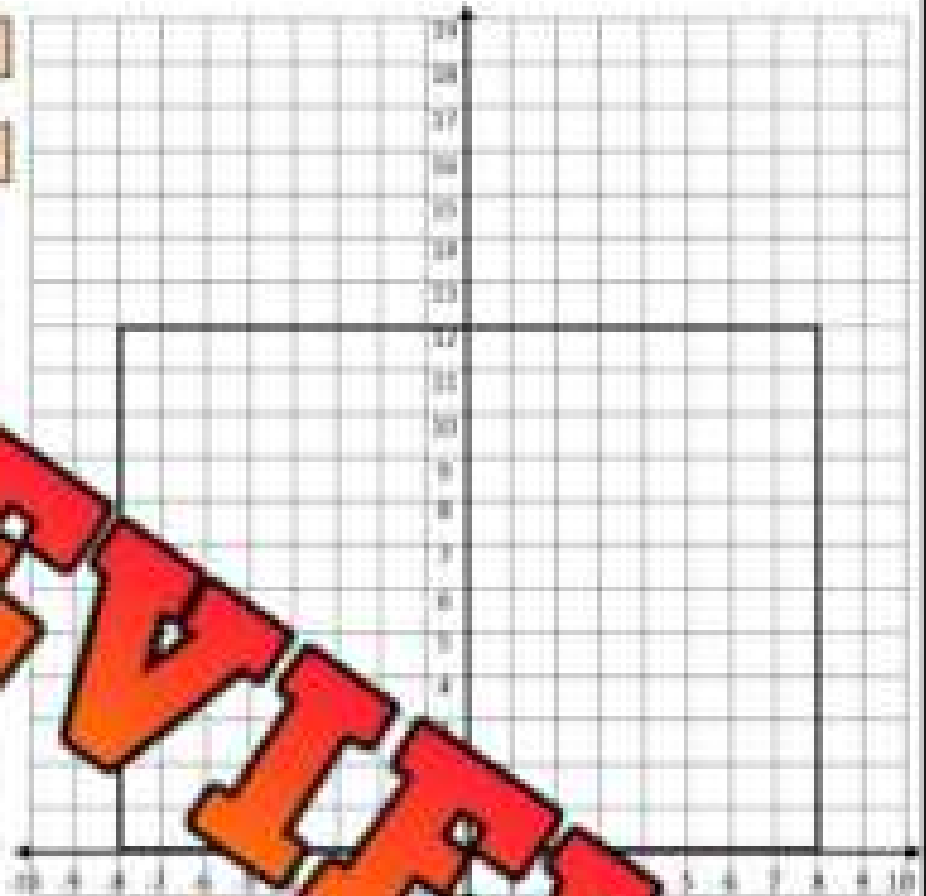

Questions

Answer the questions below

1) How many goals did Ronaldo score in the 10 games?	
2) Ronaldo plays tomorrow; do you think he will score in the game? Is it likely, unlikely, certain, or impossible?	
3) What patterns did you notice from Ronaldo's shots? List at least 2.	<hr/> <hr/> <hr/>
4) Ronaldo has asked you where he should shoot on goal. Use the data from the program to give him at least 2 tips.	<hr/> <hr/> <hr/>

Grade 8
E1 - Geometric and Spatial Reasoning

	Curriculum Expectations	Pages That Cover the Expectations
E1.1	identify geometric properties of tessellating shapes and identify the transformations that occur in the tessellations	5 - 20
E1.2	Preview of 130 pages from this product that contains 438 pages total.	
E1.3	use scale drawings to calculate actual lengths and areas, and reproduce scale drawings at different ratios	47 - 66
E1.4	describe and perform translations, reflections, rotations, and dilations on a Cartesian plane, and predict the results of these transformations	67 - 116

Intro to Tessellations

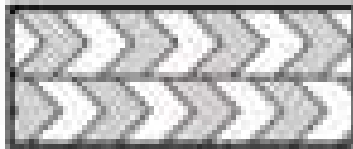

A tessellation is a tiling pattern in which shapes are fitted together with no gaps or overlaps. In the example tessellation, a white and grey chevron are tiled with no gaps and are not overlapping.

Questions: Can the shapes below be used by themselves in a tessellation?

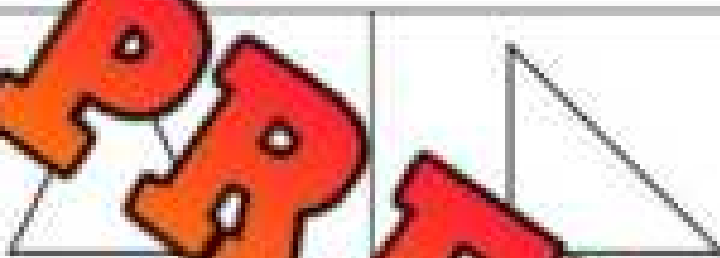

1) Yes No

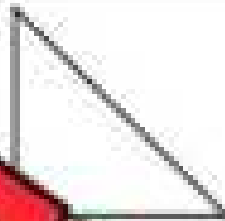

2) Yes No

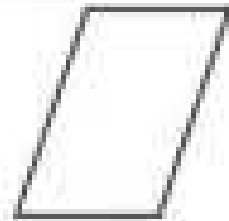

3) Yes No

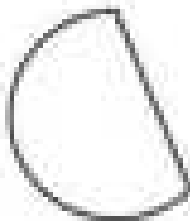

4) Yes No



5) Yes No

6) Yes No

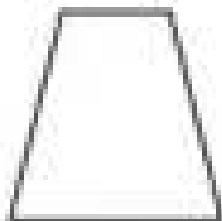

7) Yes No

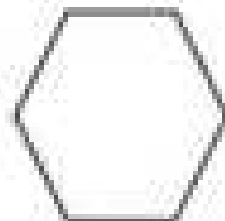

8) Yes No

9) Yes No

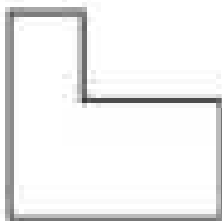

10) Yes No

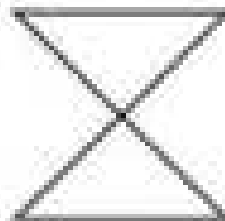

11) Yes No

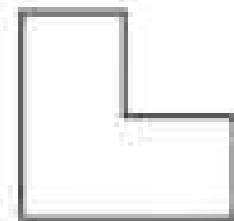





12) Yes No

Regular Polygons That Tessellate

A **regular polygon** is a shape that has equal sides and equal angles. There are only 3 regular polygons that can form tessellations by themselves. Other regular polygons can be used together to form a tessellation.

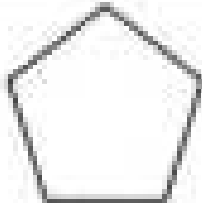
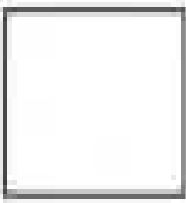
Part 1

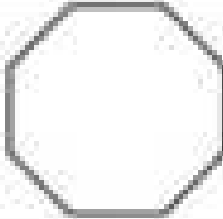
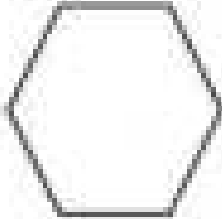
Will the regular polygon tessellate?

		
1) Yes No	2) Yes No	3) Yes No
		
4) Yes No	5) Yes No	6) Yes No
		
7) Yes No	8) Yes No	9) Yes No

Part 2

Describe the 3 regular polygons that will tessellate

Regular Polygon	Number of Sides	Angle Measurements	Interior Angle Total
1)			
2)			
3)			

Name: _____

Tessellating with Regular Polygons

Polygons will only tessellate if their interior angles add up to a multiple/factor of 360° . A triangle's interior angles always add up to 180° .

Instructions

Use the information above to fill in the tables

Terms	Definition - What does the term mean?
Regular Polygon	
Interior Angle	
Sum of Interior Angles	

Regular Polygon	Number of Triangles	Sum of Interior Angles (Number of Triangles \times 180°)	Multiple/Factor of 360° Yes/No
1) 			
2) 			
3) 			
4) 			
5) 			
6) 			
7) 			
8) 			

PREVIEW

Tessellating with Quadrilaterals

Every quadrilateral can be used to tessellate the plane. This is because a quadrilateral's interior angles always add up to 360° . A regular quadrilateral is easy to tessellate, whereas an irregular quadrilateral is sometimes more challenging to fit together.

Part 1 Fill in the table below

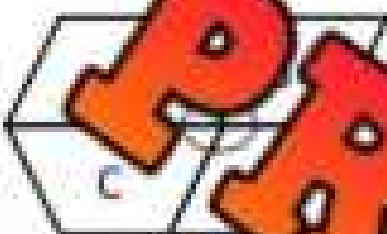
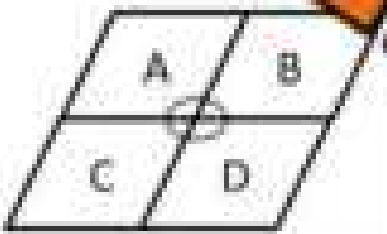
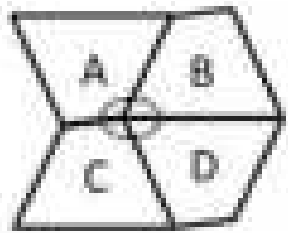
Transformation	Sum of the Circled Angles	Describe Transformation
		<i>From Shape A to Shape D</i>
		<i>From Shape A to Shape B</i>
		<i>From Shape A to Shape C</i>

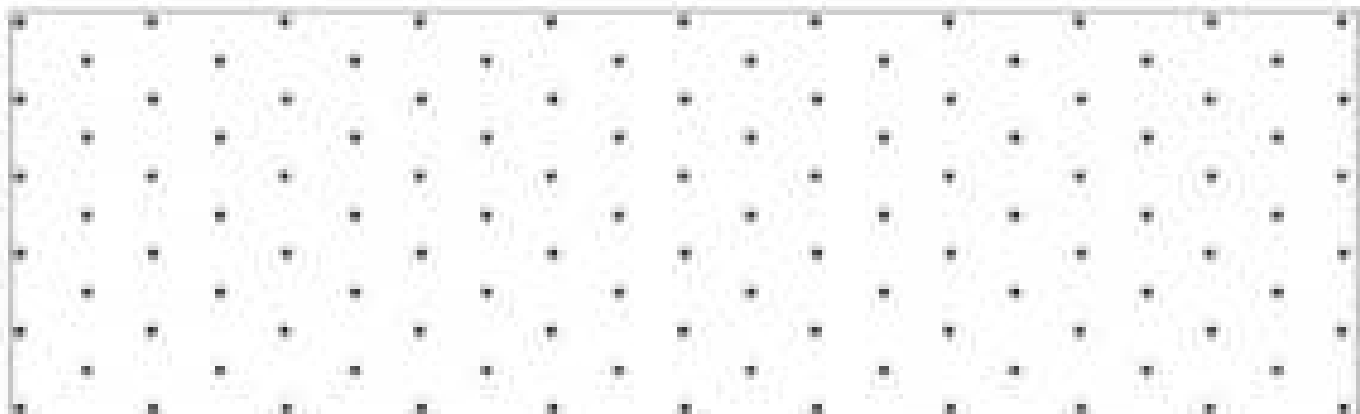

Part 2 Create a tessellation using one or multiple quadrilaterals



Types of Tessellation

Questions

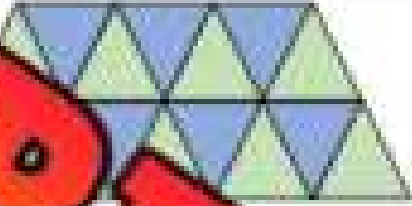
What type of tessellation are the examples below?

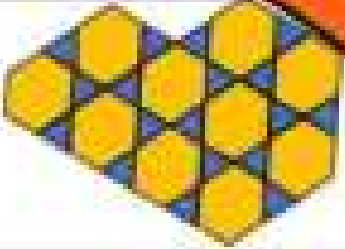
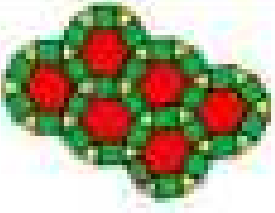
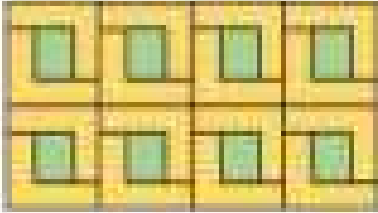
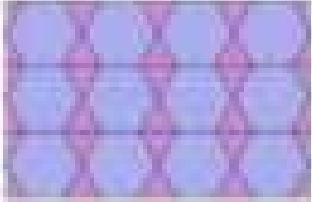
	Tessellation	Type of Tessellation Regular, Semi-Regular, Irregular
1)		
2)		
3)		
4)		
5)		
6)		

PREVIEW

Creating Translation Tessellation

Directions

Follow the instructions to create your own translation tessellation.

When creating a tessellation, we move a "tile" repeatedly to create a pattern. We can move the tile in 4 different ways – translations, reflections, rotations, and dilations.

A **translation tessellation** is a tessellation that has been created by the translating (sliding) of a tile.

Instructions

- 1) Use a square with strong paper, like cardboard, cardstock or index cards.
- 2) Use a design pencil from one corner of the square to an adjacent corner. Draw a zigzag line and do not stop halfway.
- 3) Cut along your zigzag line. You now have two pieces. The piece that you designed is called the "tile".
- 4) Translate (slide) the non-straight side of the tile and tape the straight edges together. These two pieces need to be placed exactly side-by-side with no overlapping.

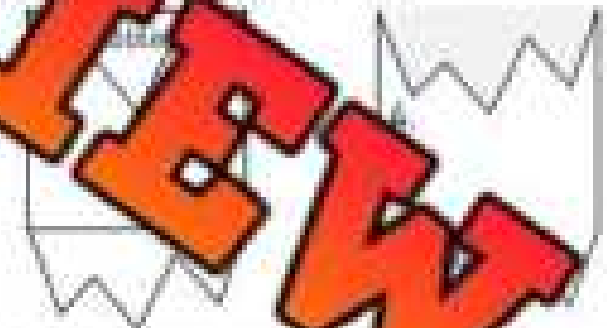
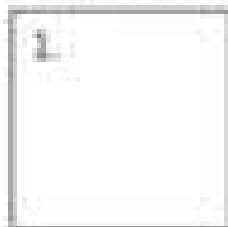

- 5) Place your tile on one of the four corners. To avoid having gaps, the top-left corner of the paper align with the original square you started with. The first tile you trace can hang off the edge of the paper.
- 6) Since this is a translation tessellation, you will translate (slide) the tile so that it fits together like a puzzle.
- 7) Continue translating the tile until the page is covered.
- 8) Colour your tessellation in a pattern.

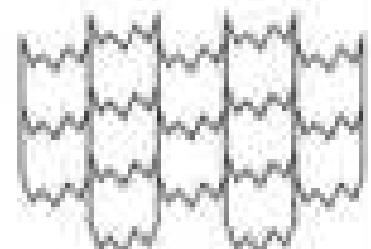

Creating Rotational Tessellation

Directions

Follow the instructions to create your own rotational tessellation

When creating a tessellation, we move a "tile" repeatedly to create a pattern. We can move the tile in 4 different ways - translations, reflections, rotations, and dilations.

A **rotational tessellation** is a tessellation that has been created by the rotating (turning) of a tile.

Instructions

- 1) Use a square of paper with strong paper, like cardboard, cardstock or index cards.
- 2) Create a design on one side of the square from one corner of the square to an adjacent corner. The design should be a simple shape, such as a bird or other animal. Do not draw diagonally. The design should be a simple shape.
- 3) Repeat the step above on the other side of the square to create two designs to cut out.
- 4) Cut both designs out. You should have two identical pieces.
- 5) **Rotate** the cut-out pieces by turning them to the other side - do not flip them. Tape the edges together making sure the pieces do not overlap.

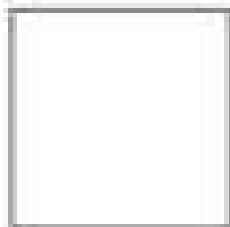

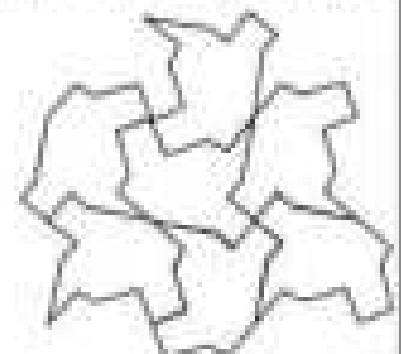

- 6) Place your tile on one of the four corners. To avoid having gaps, have the corner of the paper align with the original square you started with. The first tile you trace can hang off the edge of the paper.
- 7) Rotate (turn) the tile to fit it next to your original tile.
- 8) Continue rotating the tile until the page is covered.
- 9) Colour your tessellation in a pattern.



Describing Tessellations

Directions

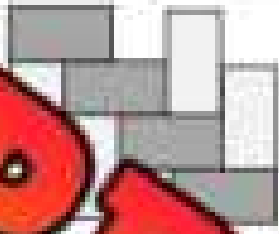
Choose one tile and describe how it is being transformed - rotated, translated, reflected and/or dilated

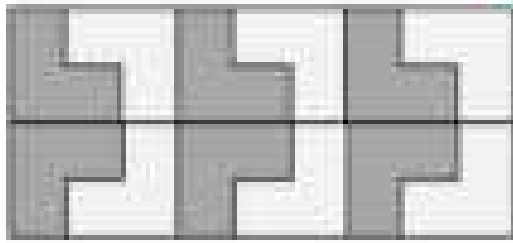
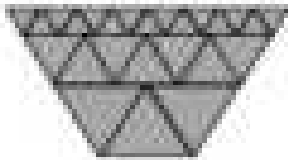
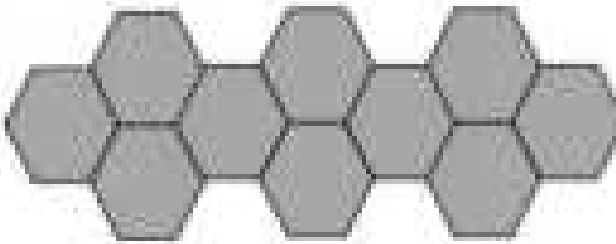
Tessellation	Description
1) 	
2) 	
3) 	
4) 	
5) 	

PREVIEW

Drawing Top, Front, and Side Views of Objects

Instructions: Draw the top, front, and side view of the objects below.

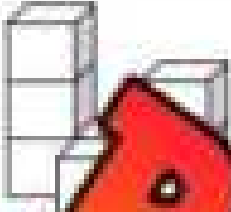
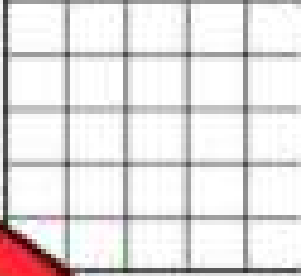
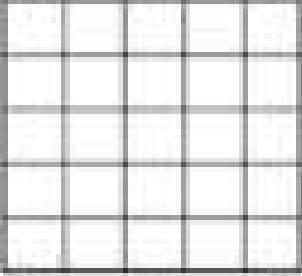
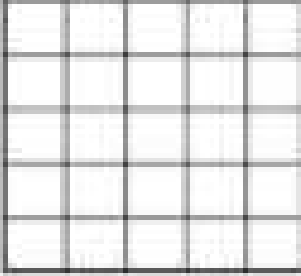
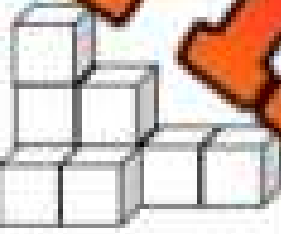
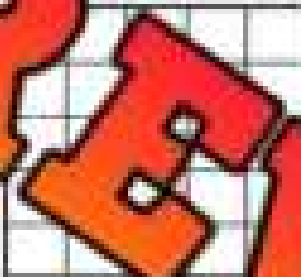
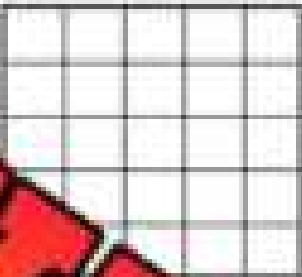
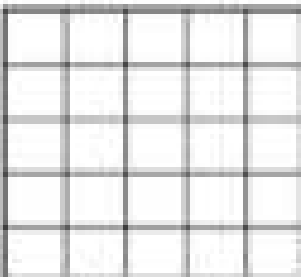
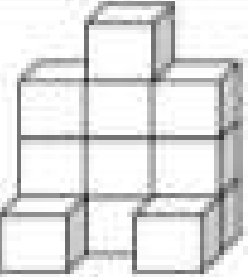
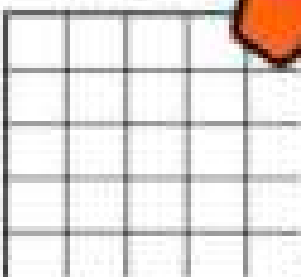
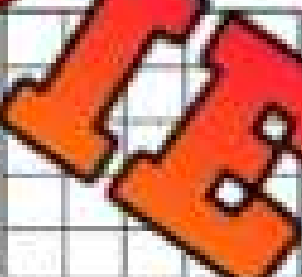
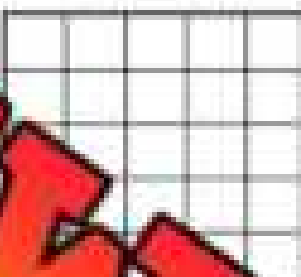
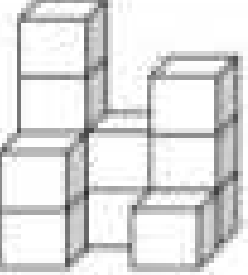
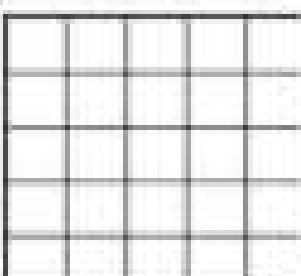
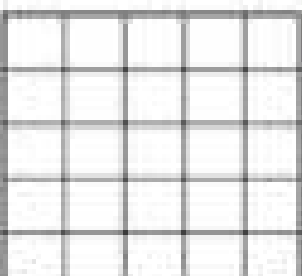
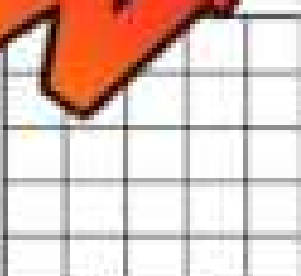
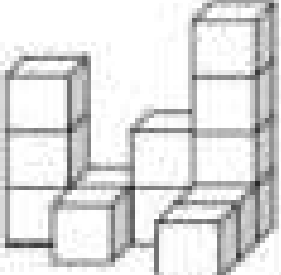
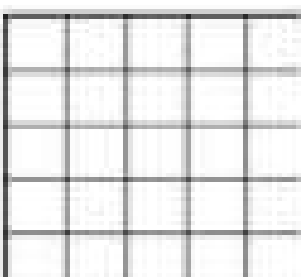
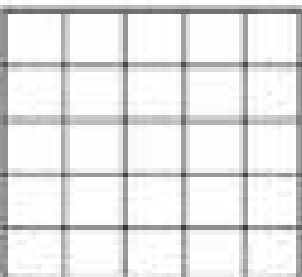
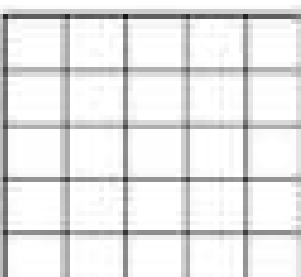
Original Shape	Top View	Front View	Side View
1) 			
2) 			
3) 			
4) 			
5) 			

PREVIEW

Drawing Top, Front, and Side Views of Objects

Instructions

Draw the top, front, and side view of the objects below

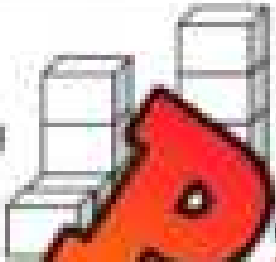
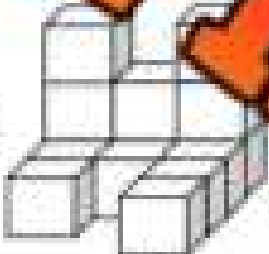
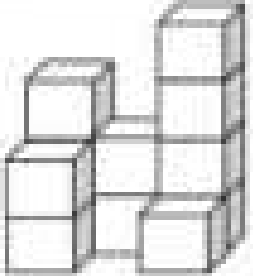
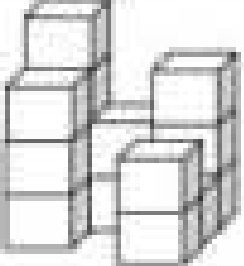
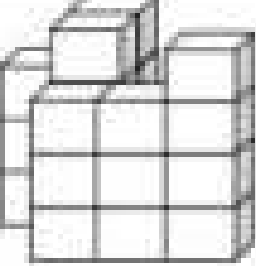
Original Shape	Top View	Front View	Side View
1) 			
2) 			
3) 			
4) 			
5) 			

PREVIEW

Drawing Top, Front, and Side Views of Objects

Instruction

Look at the front, top, and side views and circle the matching 3D object

1) Top View	Front View	Side View

2) Top View	Front View	Side View

3) Top View	Front View	Side View

4) Top View	Front View	Side View

5) Top View	Front View	Side View

6) Top View	Front View	Side View

PREVIEW

Drawing Top, Front, and Side Views of Objects

Instruction

Draw the 3D objects by using the top, front, and side views

Top View	Front View	Side View
1)		

Top View	Front View	Side View
2)		

Top View	Front View	Side View
3)		

Top View	Front View	Side View
4)		

Top View	Front View	Side View
5)		

Top View	Front View	Side View
6)		

PREVIEW

Drawing Perspective Views - Boxes

Questions

- 1) Connect the corners of the boxes to the vanishing point
- 2) Draw the sides of the boxes with horizontal lines and vertical lines

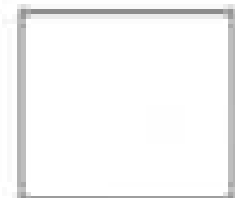
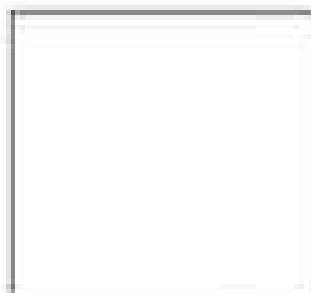
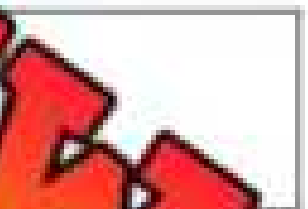
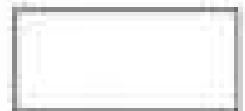
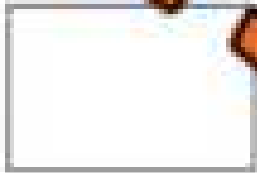

**P
R
E
V
I
E
W**

Perspective Drawings – Stars**Questions**

- 1) Connect the corners of the stars to the vanishing point.
- 2) Draw the sides of the stars parallel to the shape of the star.



Perspective Drawings – Real-Life Objects

Questions

- 1) Connect the corners of the objects to the vanishing point
- 2) Draw the sides of the objects with parallel lines

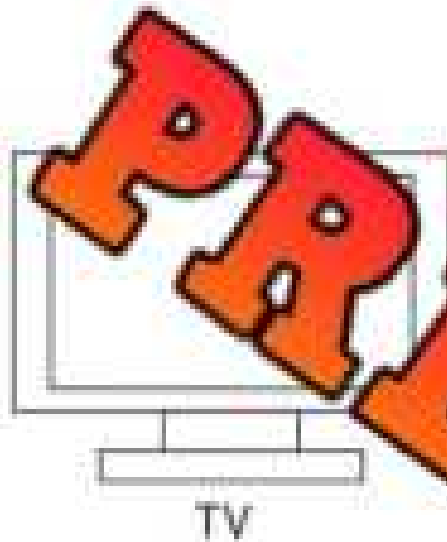

TV

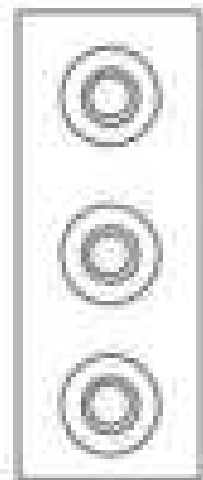

Speaker



Wastebasket

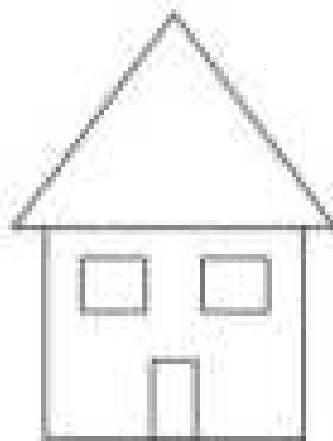

House

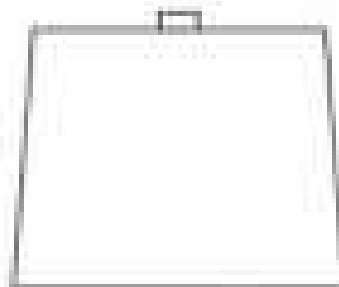

Suitcase

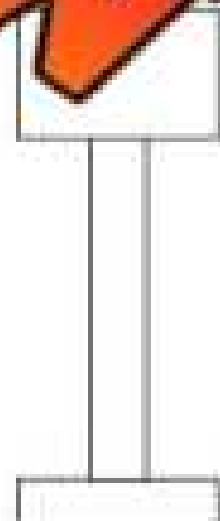

Lamp

PREVIEW

Isometric Projections

Isometric projections are drawn on a triangular grid. They are used to represent 3D objects in a 2D drawing. The projections show all lengths in the same scale, including the lines that show depth. However, angles are distorted to create the appearance of perspective. Therefore, a 90° angle in real life appears as 60° in an isometric projection.

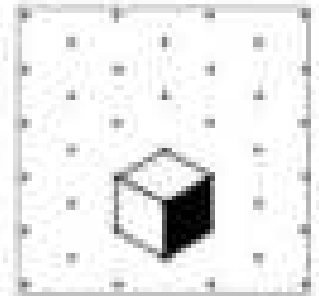

Questions

Copy the 8 three-dimensional drawings using the isometric dot paper.

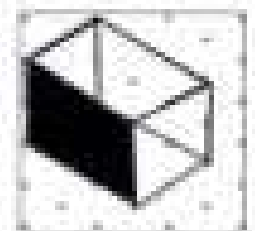
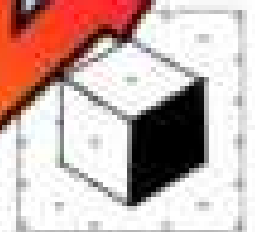
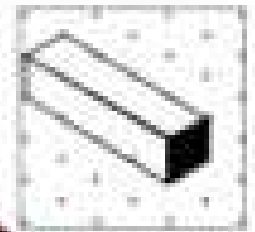
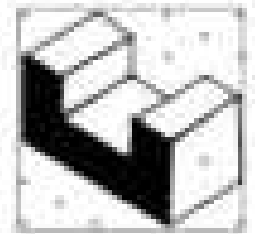
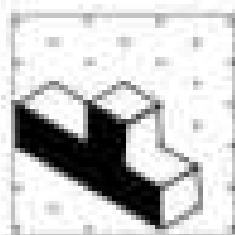
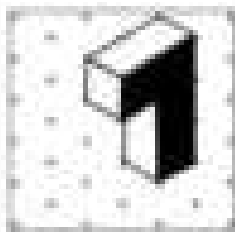
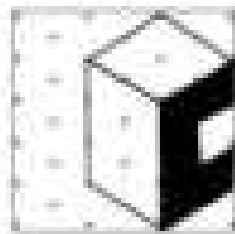



PREVIEW

Isometric Projections

Questions

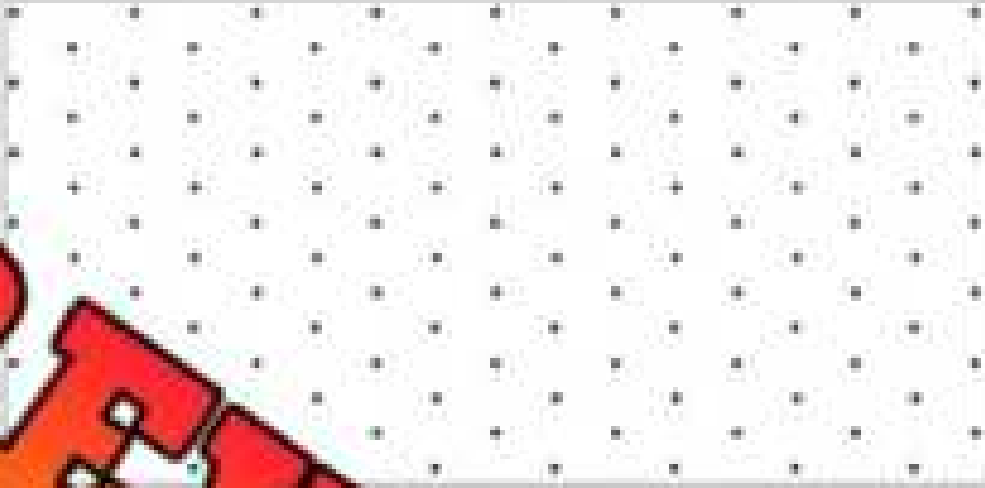
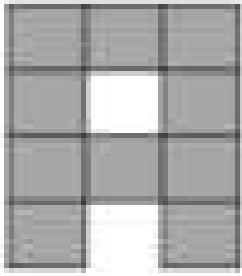
Draw the isometric view of each letter. Use a scale of 1:1.

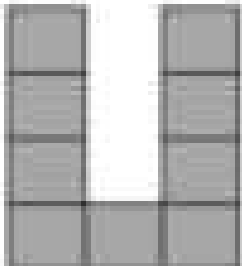
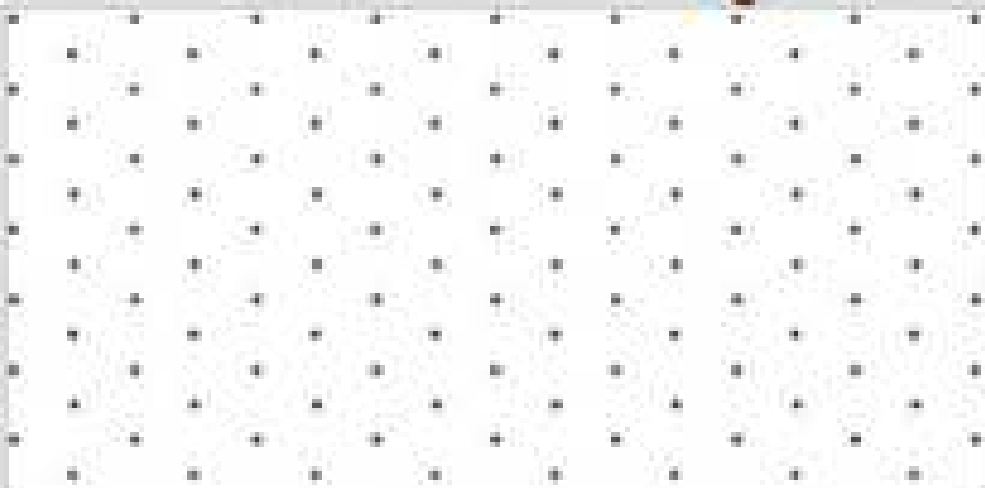
Letter	Front View	Isometric View
T		
A		
U		

Isometric Projections

Questions

Draw the top, front, and side views of the isometric drawing

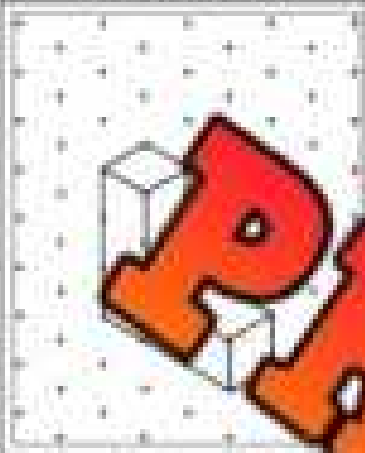
Isometric View	Top View	Front View	Side View
			

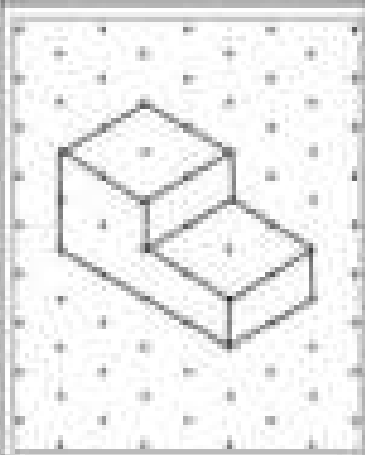
Isometric View	Front View	Side View
		

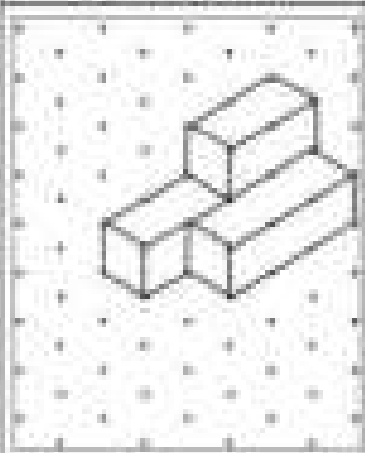
Isometric View	Top View	Front View	Side View
			

Cavalier vs Cabinet Drawings

Cavalier Drawings - Full size - All 3 Dimensions

- 1) Draw the front view first
- 2) Use the same depth as the isometric view

Cabinet Drawings - Depth is projected in half

- 1) Draw the front view first
- 2) Use half of the depth as the isometric view

Isometric View

Cube



Cavalier



Cabinet



Questions Draw the top, front, and side views of the isometric drawing

	Cavalier	Cabinet
<p>1)</p>	Cavalier	Cabinet
<p>2)</p>	Cavalier	Cabinet
<p>3)</p>	Cavalier	Cabinet

Cabinet Projections

Questions

Draw the top, front, and side views of the isometric drawing

Isometric Drawing

Cabinet Drawing

1)

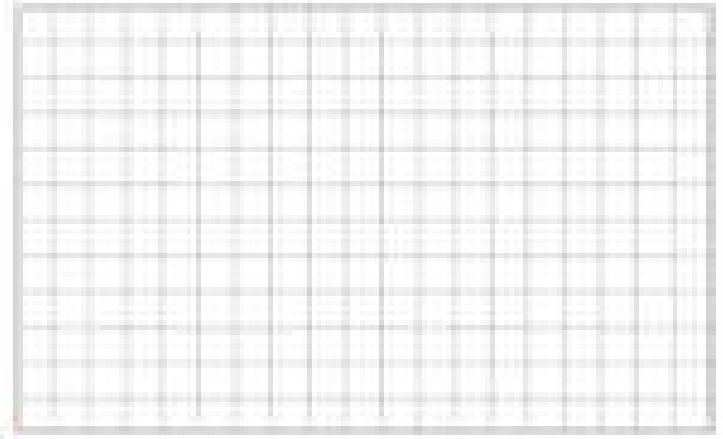
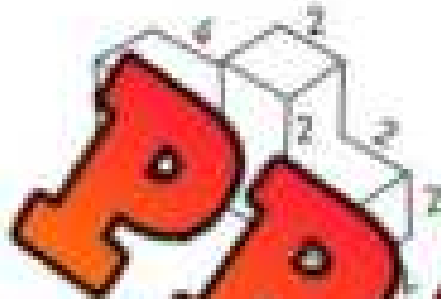

Isometric Drawing

Cabinet Drawing

2)

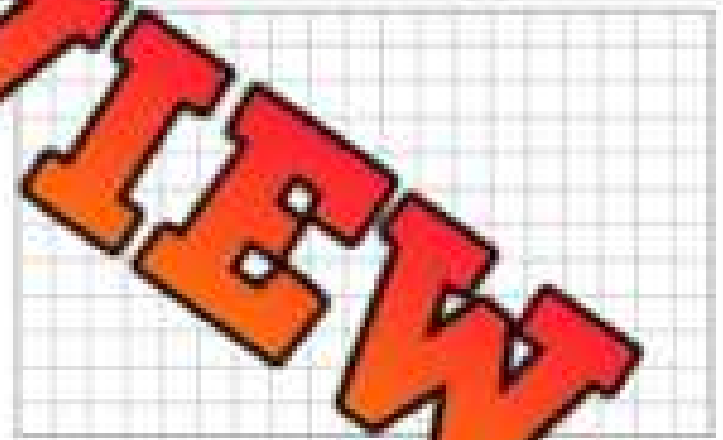
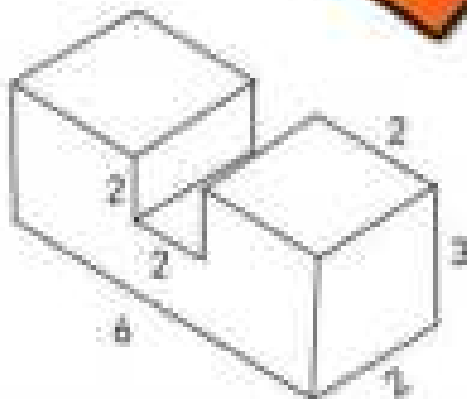

Isometric Drawing

Cabinet Drawing

3)

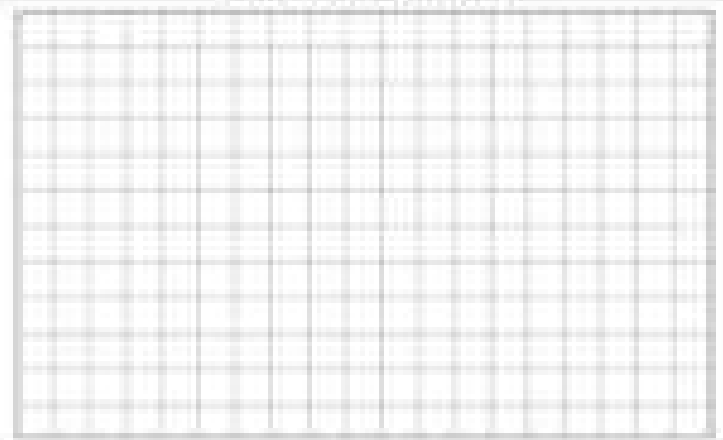
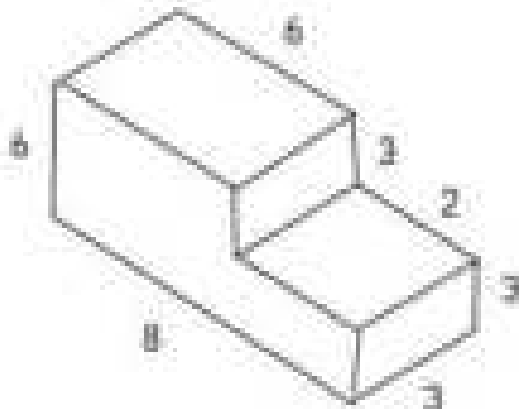

Different Drawing Types

Part 1

Label the drawings – isometric, cavalier, or cabinet

1)			
2)			
3)			

Part 2

Answer the questions below

- 1) Which type of drawing uses the exact measurements – side lengths and angles?
- 2) Which type of drawing gives the most realistic representation? Explain.

Scale Drawings

Scale Drawings

A scale drawing is used to draw a shape or object smaller or larger than the original but keeping the proportions the same. For example, the CN Tower is 553m tall. The tower on the right is to scale, with a scale of 1cm to 100m, or 1:10000.



1cm:100m

Questions: Answer the questions below

1) If a scale of 1cm equals 100m, how long would the bridge be?



2) The dimensions of a house are 18m by 34m. If one cm equals 2m, what are the scaled dimensions of the house?

3) If one cm equals 250km on a map, how many centimetres would be used to represent 3000km?

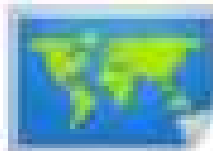

4) The length of a road is 660km. If 1cm equals 20km, how many cm would represent the length of the road?

5) Dimensions of a building are 120m by 90m. If one cm equals 15m, what are the dimensions of the building?

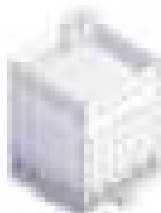

6) If one cm equals 18km on a map, how many cm would be used to represent 162km?

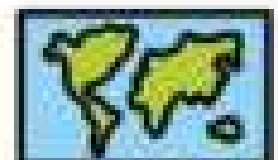

Scale Drawings

Questions

Answer the questions below.

1) An engineer used a scale of 1cm:20m to design a city park. The park will be 350m by 140m. What should the dimensions of the park be on the map?



2) A drawing of a building has been drawn to scale. The height of the building on the map is 2 cm tall. The scale is 1 cm to 6 m. What is the height of the building in real-life?



3) An artist builds a model of a car for a school project. The car is 25 cm long. The scale is 1 cm to 25 cm.

- What is the length of the car in centimetres?
- What is the length of the car in metres?



4) The height of a tree is 11 metres tall and 2.5 metres wide. Lily wants to draw it to scale so she chooses a scale of 1 cm to 0.5 m. What will the drawing of the tree be on her page in centimetres?



5) Carter is figuring out the distance to drive from Toronto to Ottawa on a map. The scale is 1 cm to 100 km. The distance on the map is 4.6 cm. What is the distance from Toronto to Ottawa in kilometres?



Exit Cards

Cut Out

Cut out the exit cards below and have students complete them at the end of class

Name: _____

Questions: Answer the questions below

1) A road map uses a scale of 1 cm to 15 km. The distance between two cities on the map is 7.8 cm. What is the actual distance between the two cities?

2) A blueprint of a house has a scale of 1 cm to 5 m. If the living room measures 4.5 cm by 6 cm on the blueprint, what are the real-life dimensions of the living room?

Name: _____

Questions: Answer the questions below

1) A road map uses a scale of 1 cm to 15 km. The distance between two cities on the map is 7.8 cm. What is the actual distance between the two cities?

2) A blueprint of a house has a scale of 1 cm to 5 m. If the living room measures 4.5 cm by 6 cm on the blueprint, what are the real-life dimensions of the living room?

Name: _____

Questions: Answer the questions below

1) A road map uses a scale of 1 cm to 15 km. The distance between two cities on the map is 7.8 cm. What is the actual distance between the two cities?

2) A blueprint of a house has a scale of 1 cm to 5 m. If the living room measures 4.5 cm by 6 cm on the blueprint, what are the real-life dimensions of the living room?

Name: _____

Questions: Answer the questions below

1) A road map uses a scale of 1 cm to 15 km. The distance between two cities on the map is 7.8 cm. What is the actual distance between the two cities?

2) A blueprint of a house has a scale of 1 cm to 5 m. If the living room measures 4.5 cm by 6 cm on the blueprint, what are the real-life dimensions of the living room?

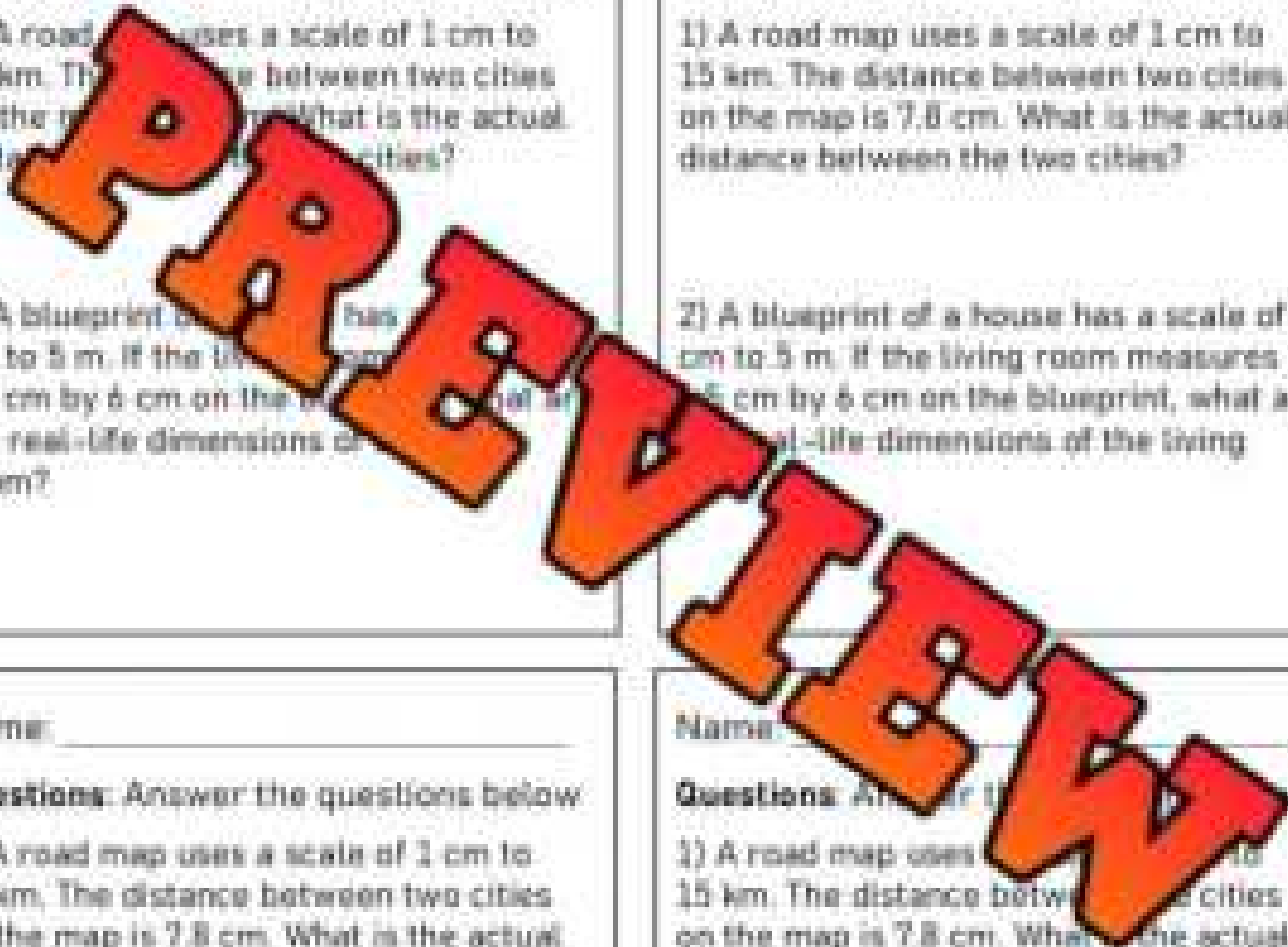

Drawing Buildings Using Scale Factors

Questions:

Use the grid to draw the dimensions of the buildings.



1 square = 1cm

1) A building's base is 36m wide and 54m long. Use a scale of 1cm to 6m.

2) A building has the following dimensions: 90m by 18m. Use a scale of 1cm to 10m.

3) A chocolate bar is 35cm long and 1.5cm wide. Use a scale of 1:5 to draw the chocolate bar on the grid.

4) A phone is 15cm by 8cm. Use a scale of 1:2 to draw the phone on the grid.

5) A book is 18cm by 28cm. Use a scale of 1:4 to draw the book on the grid.

PREVIEW

Creating Scaled Drawings

Questions

Draw the objects on the grid by choosing an appropriate scale: 1 square = 1cm

1) Building 1: 16m by 12m

Building 2: 24m by 12m

Building 3: 56m by 22m

Car: 2m by 4m

Transport: 2m by 10m

Parking lot: 26m by 16m

Scale: _____

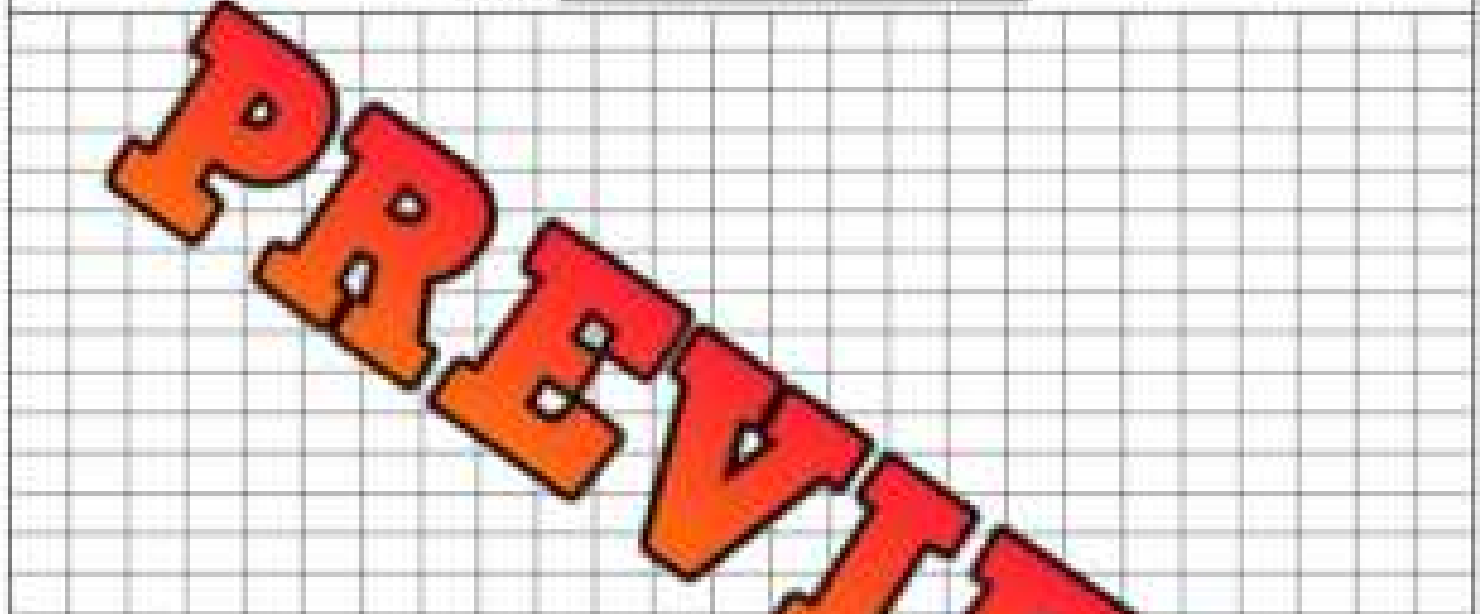

2) Building 1: 48m by 18m

Building 2: 78m by 30m

Building 3: 2m by 30m

Parking lot 1: 9m by 18m

Parking lot 2: 24m by 36m

Parking lot 3: 2m by 54m

Scale: _____

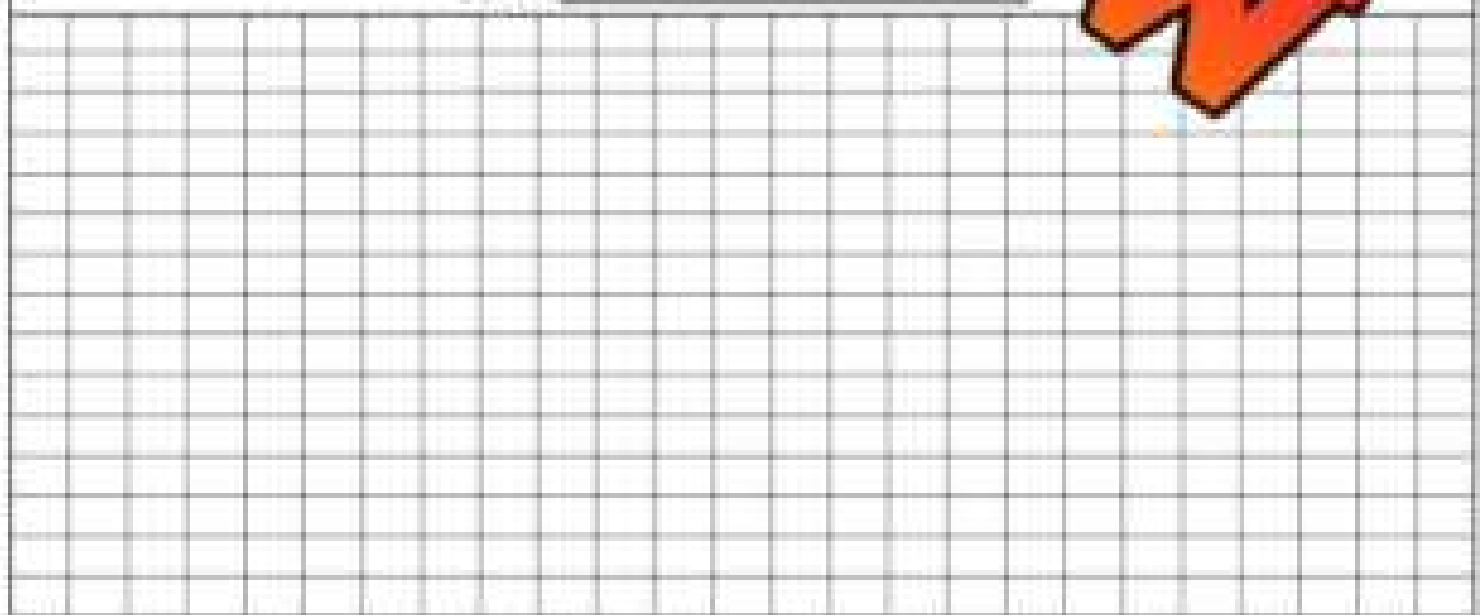

Determining the Scale

Questions

Answer the questions below

1) A park is 54m long and 24m wide. A scaled drawing was created to represent the park.



What scale was used in the drawing?

2) A rectangle has the following dimensions: 117cm by 6cm. A scaled drawing was created to represent the rectangle.



What scale was used in the drawing?

3) A tabletop has the following dimensions: 102cm by 48cm. A scaled drawing was used to represent the tabletop.



What scale was used in the drawing?

4) A computer monitor is 100cm wide and 60cm tall. A scaled drawing was used to represent the monitor.

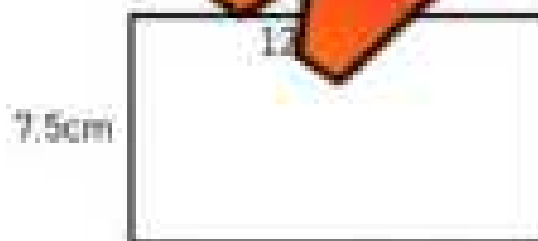

What scale was used in the drawing?

5) The distance from Yellowknife to Toronto is 4,250km. Vincent measured the distance on a map and determined it was 8.5cm.

What scale was used on the map?



Using Scale on Map of Canada

Questions

Print this using default settings to achieve a friendly scale



Using Scale on Map of Canada

Use the legend on the map of Canada to determine the distances between cities.

- 1) Measure the length of the scale provided on the legend. Use the kilometre measurement (not miles).
- 2) Determine the scale by comparing the length of the line to the measurement provided.

For example: km 0 100 200 300



The length of the line is 3cm total. This means 1cm = 100km.



Question: Use the scale to determine the distance from city to city

	City 1	City 2	Distance - cm	Distance - km
1)	Toronto	Montreal		
2)	Winnipeg	Halifax		
3)	Victoria	Regina		
4)	Kingston	Saskatoon		
5)	Vancouver	Charlottetown		
6)	Prince Rupert	St. John's		
7)	Calgary	Timmins		
8)	Thunder Bay	Moncton		
9)	Sudbury	Whitehorse		
10)	Dawson City	Brandon		
11)	Edmonton	Yellowknife		
12)	Iqaluit	Montreal		
13)	Halifax	Fort McMurray		

Calculating Area Using Scale Drawings

We can determine the area of region or object by using its scaled dimensions. We do this by determining the actual dimensions and then using them in the formula for area - length times width ($A = L \times W$)

Example: A park is 8cm by 9cm on a map. The scale is 1cm:20m.

Actual Dimension: 160m x 180m
Area = 160 x 180 = 28 800 m²

Questions

Calculate the area using the scaled dimensions

1) A driveway is 5cm by 8cm on a scaled drawing. The scale is 1cm:12m. What is the actual area of the driveway?

2) A TV has been drawn to scale with dimensions of 10cm by 9cm. The scale is 1cm:8cm. What is the actual area of the TV?

3) You are deciding whether to buy the latest smartphone but you don't know the area of it. A scaled drawing shows it is 8mm by 4mm. The scale is 1mm:1cm. What is the actual area of the phone?





4) A painting you are thinking of buying online has been drawn to scale with the following dimensions: 9cm by 16cm. The scale in centimetres is 1:12. What is the actual area of the painting?

5) Neill is buying a lot to build his house on. He has seen a scaled drawing of the lot that measured 14cm by 22cm. The scale used was 1cm to 4m. What is the area of the lot?

Calculating Area Using Scale Drawings

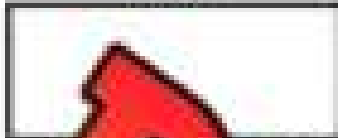
Questions

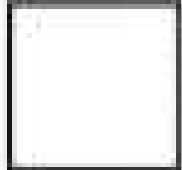
Fill in the table below

Scaled Drawing	Area of Scaled Drawing	Area of Actual Region
1) 		
2)  Scale = 1cm:8m		
3)  Scale = 1cm:10m		
4)  Scale = 1cm:20m		
5)  Scale = 1cm:1000m		

PREVIEW

Exit Cards

Cut Out

Cut out the exit cards below and have students complete them at the end of class

Name: _____

1) Calculating Area Using Scale Drawings

Scale = 1cm:3m



Area of Scaled Region = _____

2) A scaled blueprint of a rectangular park shows dimensions of 25 cm by 10 cm. The scale is 1 cm:5 m. What is the actual area of the park?

Name: _____

1) Calculating Area Using Scale Drawings

Scale = 1cm:3m



Area of Scaled Region = _____

2) A scaled blueprint of a rectangular park shows dimensions of 25 cm by 10 cm. The scale is 1 cm:5 m. What is the actual area of the park?

Name: _____

1) Calculating Area Using Scale Drawings

Scale = 1cm:3m



Area of Scaled Region = _____

2) A scaled blueprint of a rectangular park shows dimensions of 25 cm by 10 cm. The scale is 1 cm:5 m. What is the actual area of the park?

Name: _____

1) Calculating Area Using Scale Drawings

Scale = 1cm:3m



Area of Scaled Region = _____

2) A scaled blueprint of a rectangular park shows dimensions of 25 cm by 10 cm. The scale is 1 cm:5 m. What is the actual area of the park?

Calculating Area Using Scale Drawings

Questions

Answer the word problems below.

1) A scale drawing for a park is shown below. The park has some greenspace and a basketball court. The scale in the drawing is 1cm to 5m.

a) What is the area of the basketball court?



b) What is the area of the entire park?

c) What is the area of the greenspace?

2) Courtney is painting a wall in her house. She is shown the wall that is shown below. The scale that was used in centimetres is 1:50.

a) What is the area of the wall in centimetres?



b) If the paint for the wall costs \$5.35 to cover 1 metre of wall, how much will it cost Courtney to paint her wall?

Area Using Scale Factor

A scale factor is the number by which all dimensions of an object are multiplied in order to create a proportionally larger or smaller representation. If the scale factor is a whole number, the representation will be larger. If the scale factor is a fraction or decimal smaller than 1, it will become smaller.

Example using 2 as scale factor:

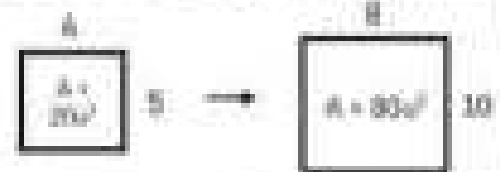

Questions

State the area of the original shape and the area of the scaled drawing.



	Scaled Drawing
1) <div style="display: flex; justify-content: space-between; width: 100%;"> Area = _____ Scale Factor = 2 Area = _____ </div>	
2) <div style="display: flex; justify-content: space-between; width: 100%;"> Area = _____ Scale Factor = 3 Area = _____ </div>	
3) <div style="display: flex; justify-content: space-between; width: 100%;"> Area = _____ Scale Factor = 3 Area = _____ </div>	
4) <div style="display: flex; justify-content: space-between; width: 100%;"> Area = _____ Scale Factor = 0.5 Area = _____ </div>	
5) <div style="display: flex; justify-content: space-between; width: 100%;"> Area = _____ Scale Factor = 1/3 Area = _____ </div>	

PREVIEW

Area Using Scale Factor

Questions

Calculate the area of the original shape and the area of the scaled drawing

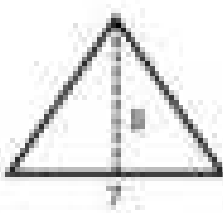
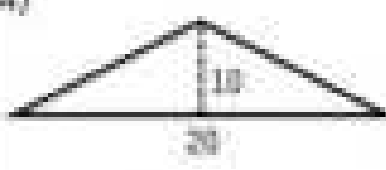
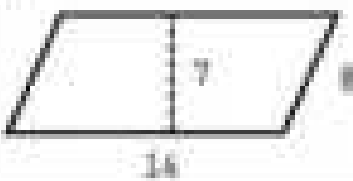
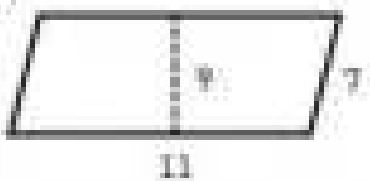
Original Shape	Scaled Drawing
1)  Area = _____	Scale Factor = $\frac{1}{2}$ Area = _____
2)  Area = _____	Scale Factor = 4 Area = _____
3)  Area = _____	Scale Factor = _____ Area = _____
4)  Area = _____	Scale Factor = $\frac{1}{2}$ Area = _____
5)  Area = _____	Scale Factor = 2 Area = _____
6)  Area = _____	Scale Factor = 3 Area = _____

PREVIEW

Enlargement and Reductions

An **enlargement** is when we enlarge a shape by a scale factor to form a similar shape. A **reduction** is when we shrink a shape by a scale factor to form a similar shape. A **similar shape** is a shape that has the same angles and the side lengths have been changed proportionally. For example, if we change the length by 2 times, we change the width by 2 times as well.

Questions Use the scale factor to perform enlargements/reductions of the original shape

Ex 1) Scale Factor = 2 (enlarge 2 times)

Original (O)



1) Scale Factor = 1:2

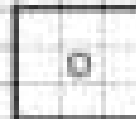

2) Scale Factor = 1:3



3) Scale Factor = 1:4



4) Scale Factor = 2:1 (reduction)

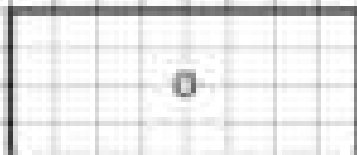

5) Scale Factor = 3:1

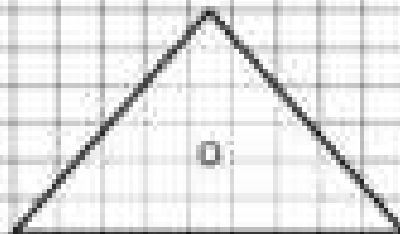

Intro to Dilations

A **dilation** is a transformation that stretches or shrinks a figure by a certain scale factor. Unlike translations, reflections, and rotations, a dilation does not produce a congruent image. Instead, a dilated image produces a similar figure that has the same shape with equal angles and proportional side lengths.

When the scale factor is greater than 1, we are enlarging the original figure. If it is less than 1, we are reducing the original figure.

Part 1 Scale factors a dilation with the given scale factor is a reduction or enlargement.

	Scale Factor	Dilation Type		Scale Factor	Dilation Type
1)	$k = 3$		6)	$k = \frac{1}{2}$	
2)	$k = 2$		7)	$k = 5$	
3)	$k = \frac{1}{3}$		8)	$k = 0.25$	
4)	$k = 0.5$		9)		
5)	$k = 0.75$		10)		

Part 2 Is the dilation from figure A to B an enlargement or reduction?

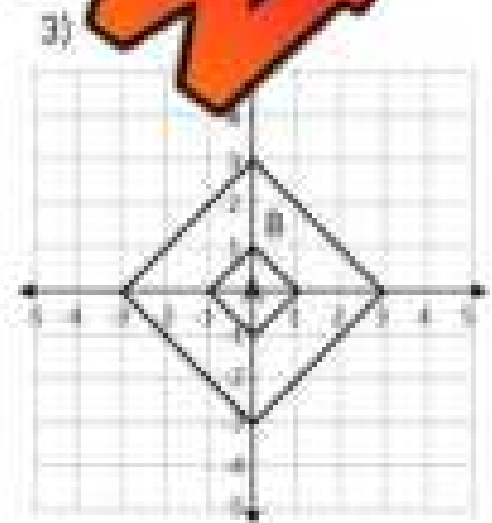
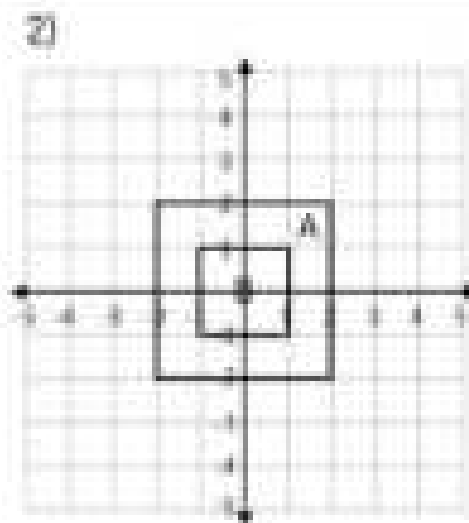
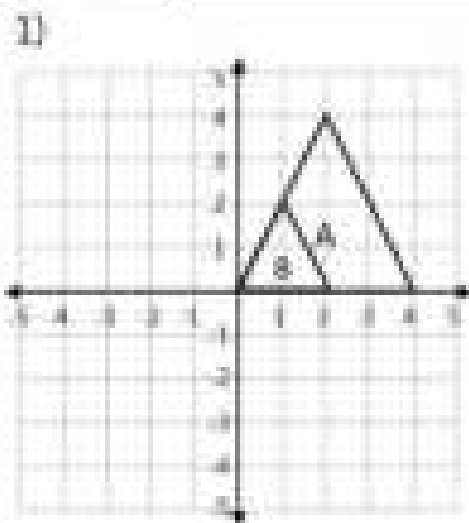

Dilations – Determining Scale Factors

Questions

Is the dilation from A to B an enlargement or reduction? What is the scale factor?

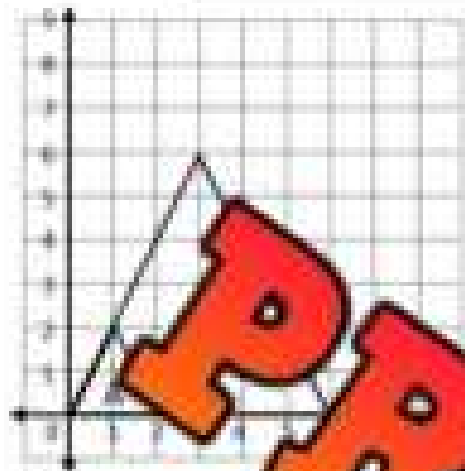
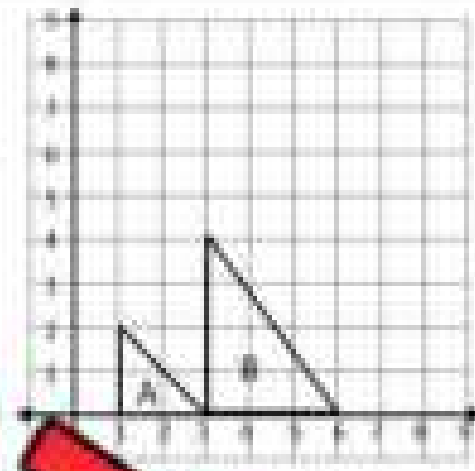
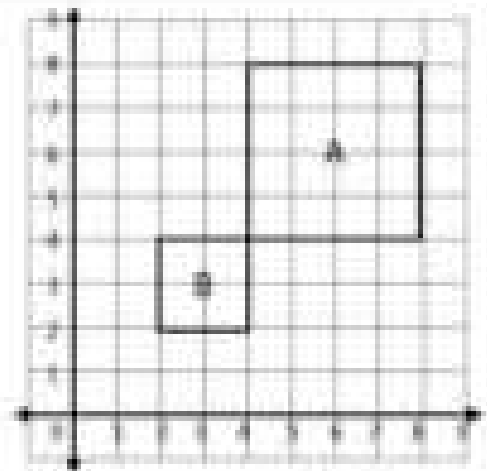
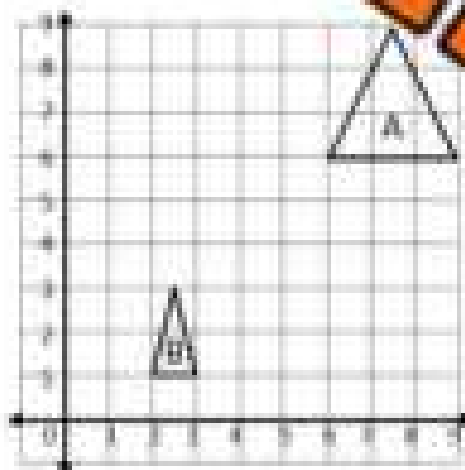
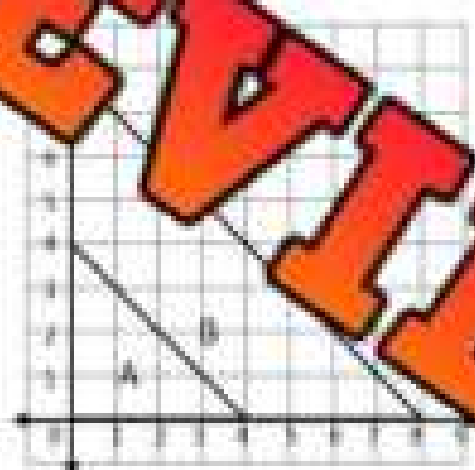
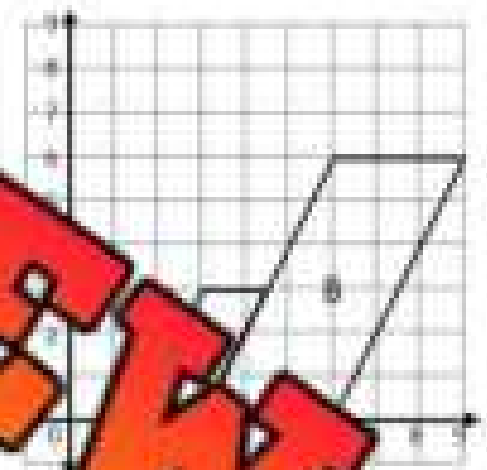
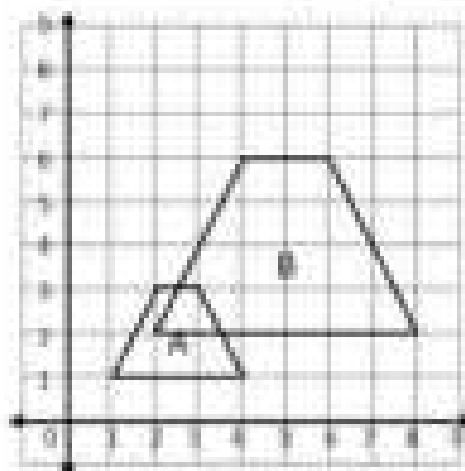
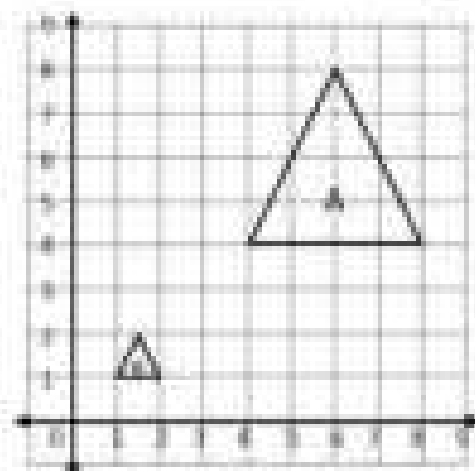
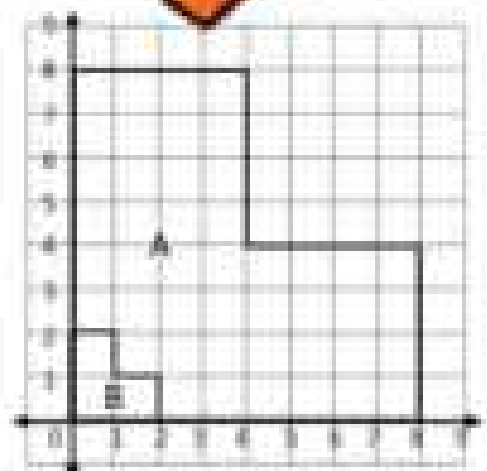
 1) _____ $k =$ _____

 2) _____ $k =$ _____

 3) _____ $k =$ _____

 4) _____ $k =$ _____

 5) _____ $k =$ _____

 6) _____ $k =$ _____

 7) _____ $k =$ _____

 8) _____ $k =$ _____

 9) _____ $k =$ _____

Dilations – Finding New Coordinates

The mapping rules for dilations help us determine where the new coordinates will be after we have transformed the original points by a scale factor.

Mapping Rule: $(x, y) \rightarrow (kx, ky)$ where k = scale factor

For example, $(x, y) \rightarrow (2x, 2y)$; each of the image points are double the original points because the scale factor is 2. Therefore, the image point for $(-3, 4)$ would be $(-6, 8)$.

Part 1 Find the dilated coordinates of the triangles below

	Coordinate A	Coordinate B	Coordinate C
Original Coordinates	(3, 4)	(-3, 5)	(8, 0)
Dilated Coordinates			

2) $k = 1/4$	Coordinate A	Coordinate B	Coordinate C
Original Coordinates	(-4, 12)	(4, 12)	(-2, 4)
Dilated Coordinates			

3) $k = 1.5$	Coordinate A	Coordinate B	Coordinate C
Original Coordinates	(2, -4)	(4, -4)	(8, -10)
Dilated Coordinates			

Part 2 Find the dilated coordinates of the quadrilaterals below

1) $k = 3$	Coordinate A	Coordinate B	Coordinate C	Coordinate D
Original Coordinates	(-2, 5)	(-1, 4)	(4, 5)	(-3, 7)
Dilated Coordinates				

2) $k = 2$	Coordinate A	Coordinate B	Coordinate C	Coordinate D
Original Coordinates	(1, 5)	(-4, 3)	(2, -6)	(5, -8)
Dilated Coordinates				

3) $k = 1/2$	Coordinate A	Coordinate B	Coordinate C	Coordinate D
Original Coordinates	(-4, 6)	(-10, 6)	(5, -8)	(12, -9)
Dilated Coordinates				

Exit Cards

Cut Out

Cut out the exit cards below and have students complete them at the end of class.

Name: _____

Questions: Answer the questions below.

State the new coordinates of a point after a dilation with the given scale factor. Use the point $(x, y) = (3, 2)$ as the original.

- A) Scale Factor $k = 3$ _____
- B) Scale Factor $k = 0.5$ _____
- C) Scale Factor $k = 3/4$ _____
- D) Scale Factor $k = 0.25$ _____
- E) Scale Factor $k = 4/2$ _____

Name: _____

Questions: Answer the questions below.

State the new coordinates of a point after a dilation with the given scale factor. Use the point $(x, y) = (3, 2)$ as the original.

- A) Scale Factor $k = 3$ _____
- B) Scale Factor $k = 0.5$ _____
- C) Scale Factor $k = 3/4$ _____
- D) Scale Factor $k = 0.25$ _____
- E) Scale Factor $k = 4/2$ _____

Name: _____

Questions: Answer the questions below.

State the new coordinates of a point after a dilation with the given scale factor. Use the point $(x, y) = (3, 2)$ as the original.

- A) Scale Factor $k = 3$ _____
- B) Scale Factor $k = 0.5$ _____
- C) Scale Factor $k = 3/4$ _____
- D) Scale Factor $k = 0.25$ _____
- E) Scale Factor $k = 4/2$ _____

Name: _____

Questions: Answer the questions below.

State the new coordinates of a point after a dilation with the given scale factor. Use the point $(x, y) = (3, 2)$ as the original.

- A) Scale Factor $k = 3$ _____
- B) Scale Factor $k = 0.5$ _____
- C) Scale Factor $k = 3/4$ _____
- D) Scale Factor $k = 0.25$ _____
- E) Scale Factor $k = 4/2$ _____

Performing Dilations

Instructions

Draw the dilated shape on the grid

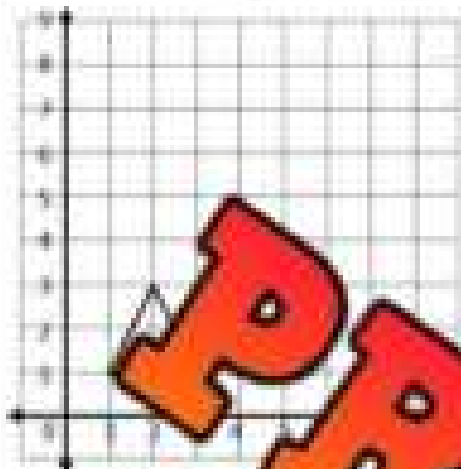
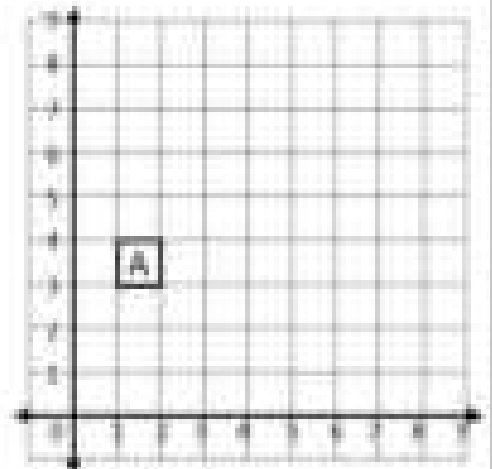
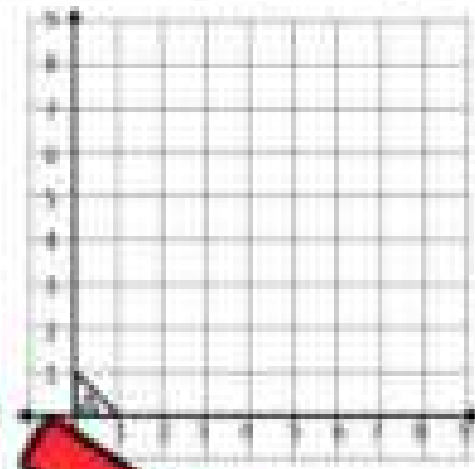
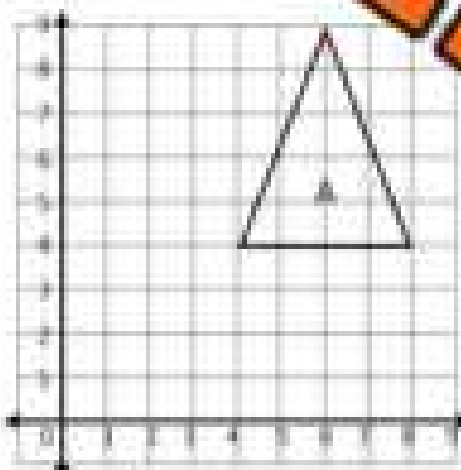
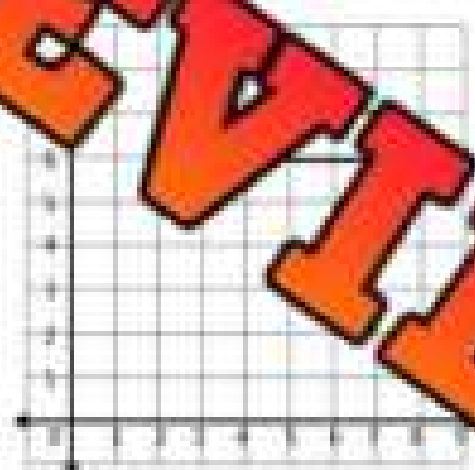
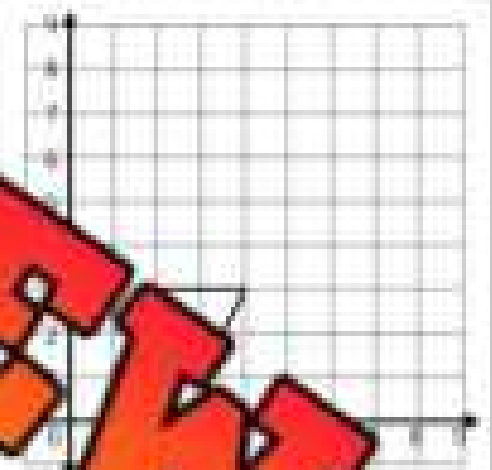
1) $k = 3$ 3) $k = 2$ 4) $k = \frac{1}{2}$ 5) $k = \frac{1}{3}$ 

6)

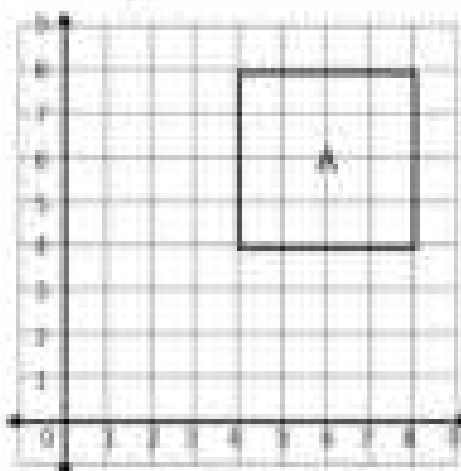
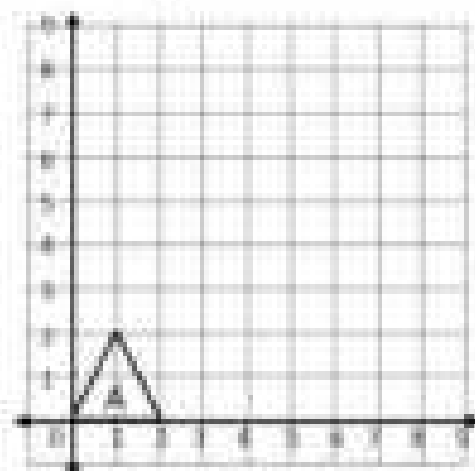
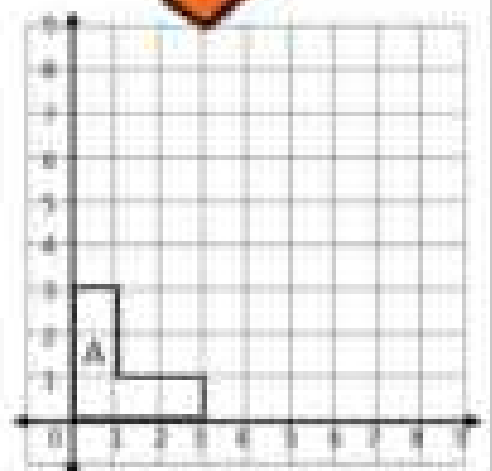
7) $k = 0.25$ 8) $k = 4$ 9) $k = 2.5$

Translations – Mapping Rules

Mapping Rules for Translations

Each point on a shape slides according to the mapping rule.

The rule is $(x, y) \rightarrow (x + a, y + b)$

- 1) Choose 1 coordinate from the shape to translate
- 2) We need to move the x coordinate -4 spaces to the left. This means we subtract 4.
- 3) We need to move the y coordinate +5 spaces up. This means we add 5.
- 4) The mapping rule is: $(x, y) \rightarrow (x - 4, y + 5)$
- 5) Remember: if we move to the left or down, we are subtracting and if we move up, we are adding a positive number.

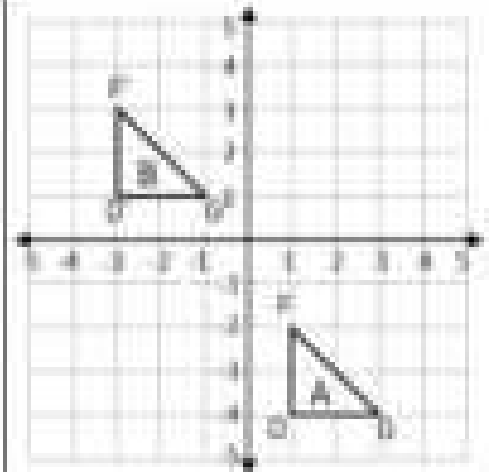

Instructions

Write the mapping rule that translates figure A to figure B.

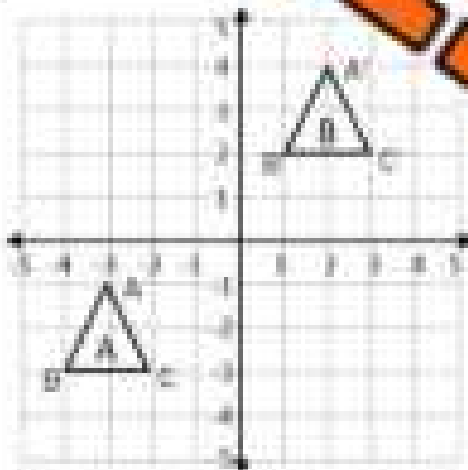

Mapping Rule: $(x \square, y \square)$

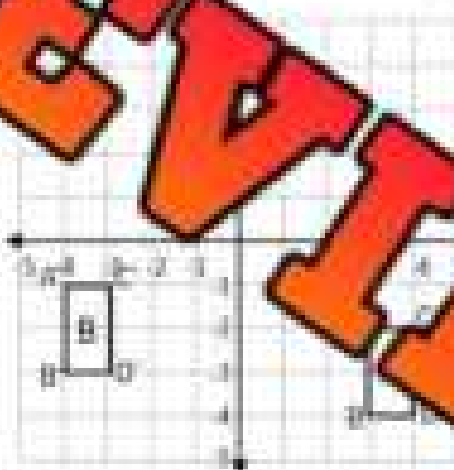

Mapping Rule: $(x \square, y \square)$

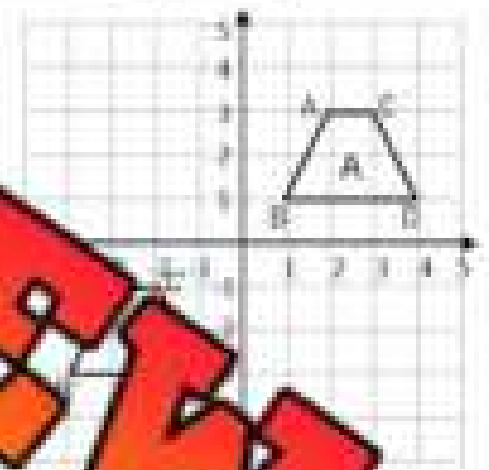

Mapping Rule: $(x \square, y \square)$

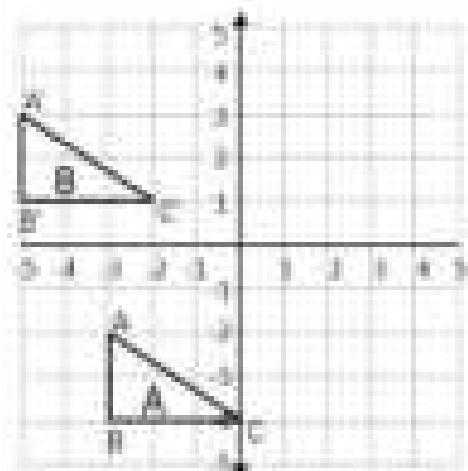

Mapping Rule: $(x \square, y \square)$

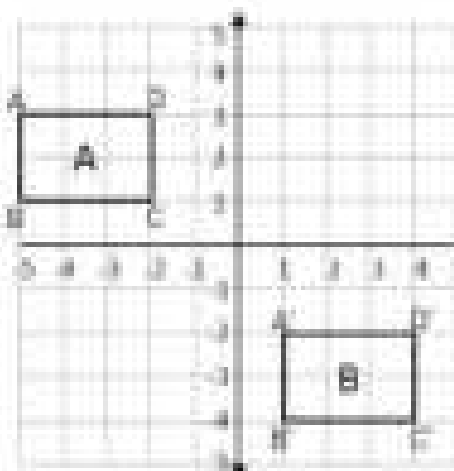

Mapping Rule: $(x \square, y \square)$

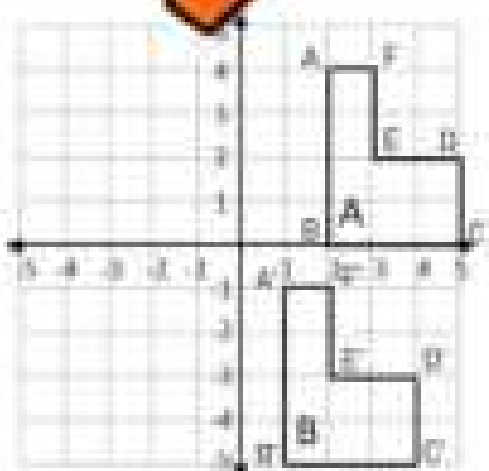

Mapping Rule: $(x \square, y \square)$

Math Activity: Translation Relay Race

Objective

What are we learning about?

To help students understand and describe translations using mapping rules on a Cartesian plane through a fun and engaging relay race activity.

Materials

What you will need for the activity.

- Graph paper
- Protractors
- Colored pencils/markers
- Pens and pencils
- Translation task cards



Instructions

How to run the activity

1. **Explain Translations:** Start by explaining translations on the Cartesian plane, which involve moving shapes without rotation or resizing. Introduce the concept of mapping rules (e.g., $(x, y) \rightarrow (x+3, y)$).
2. **Distribute Materials:** Provide each team with graph paper and a set of translation task cards with mapping rules.
3. **Form Teams:** Divide the class into small teams, each with a designated leader. Give them their graph paper and task cards.
4. **Translation Task:** The first student in each team picks a translation task card and then plots the point on the grid at the given coordinates – e.g., $(2, 3)$.
5. **Perform Translation:** The student then applies the mapping rule from the task card to the point's coordinates and draws the new position on the grid.
6. **Pass to Next Student:** The student then goes to the end of the line, and the next student steps up.
7. **Repeat Process:** The next student repeats the process.
8. **Continue Relay:** Continue the relay until all team members have had a turn or all task cards are used.
9. **Verification and Discussion:** The teacher verifies the translations, and the class discusses the different translations and observations.

Task Cards

Cut out the task cards below

Card 11:Start: $(0, -4)$ Mapping Rule: $(x, y) \rightarrow (x+5, y+2)$ **Card 16:**Start: $(4, 4)$ Mapping Rule: $(x, y) \rightarrow (x+3, y+1)$ **Card 17:**Start: $(0, -3)$ Mapping Rule: $(x, y) \rightarrow (x+5, y+4)$ **Card 13:**Start: $(-5, 1)$ Mapping Rule: $(x, y) \rightarrow (x+2, y+5)$ **Card 18:**Start: $(2, 2)$ Mapping Rule: $(x, y) \rightarrow (x-8, y-8)$ **Card 14:**Start: $(-2, -5)$ Mapping Rule: $(x, y) \rightarrow (x+7, y+4)$ **Card 19:**Start: $(5, 1)$ Mapping Rule: $(x, y) \rightarrow (x+3, y+3)$ **Card 15:**Start: $(-4, 1)$ Mapping Rule: $(x, y) \rightarrow (x+6, y+4)$ **Card 20:**Start: $(-3, 0)$ Mapping Rule: $(x, y) \rightarrow (x+4, y+4)$ **PREVIEW**

Grid Paper

Use the cartesian plane to perform the translations.

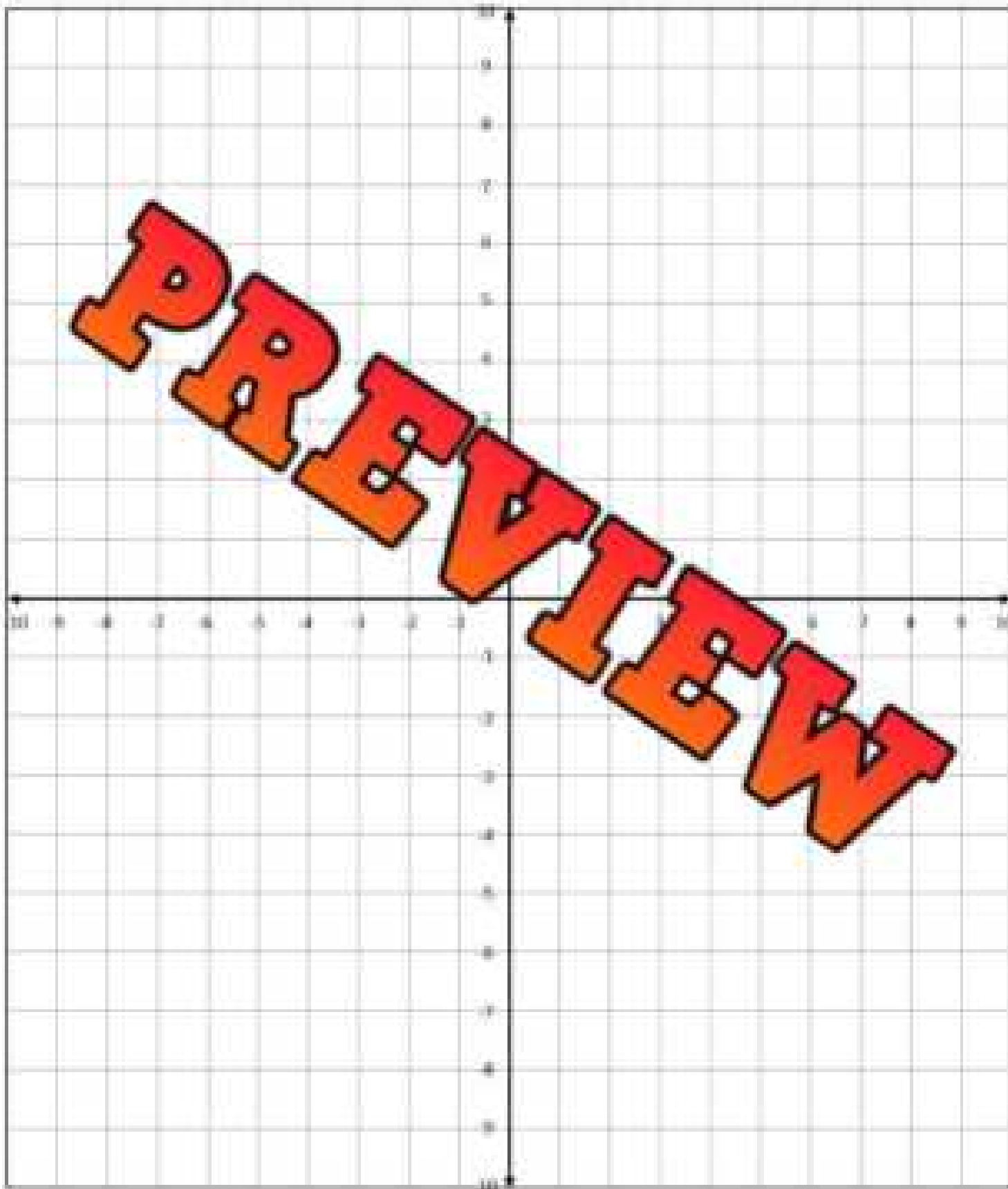

Exit Cards

Cut Out Cut out the exit cards below and have students complete them at the end of class.

Name: _____

Translate the shape using the mapping rule.

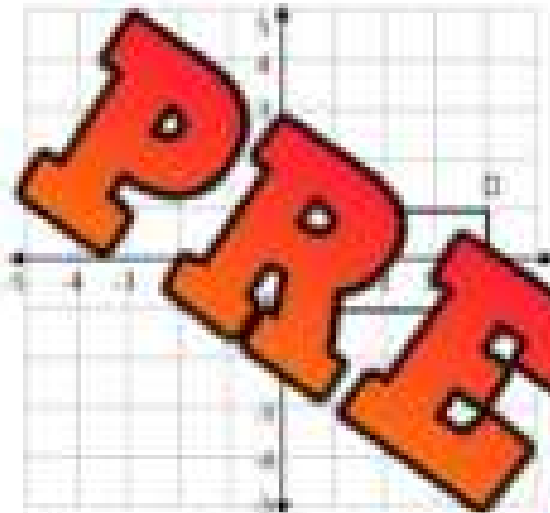

Mapping Rule: $(x + 4, y - 3)$

Name: _____

Translate the shape using the mapping rule.

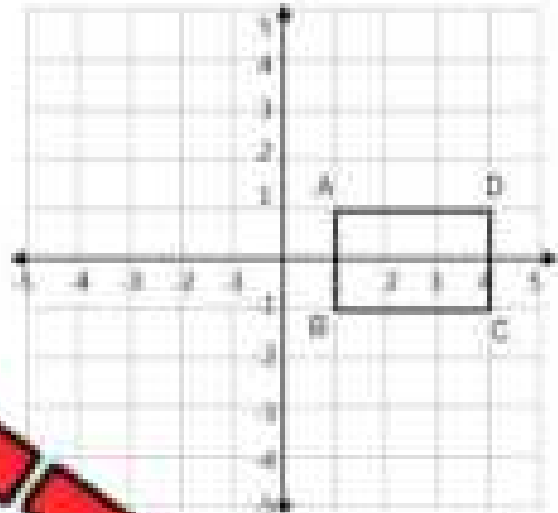

Mapping Rule: $(x + 4, y - 3)$

Name: _____

Translate the shape using the mapping rule.

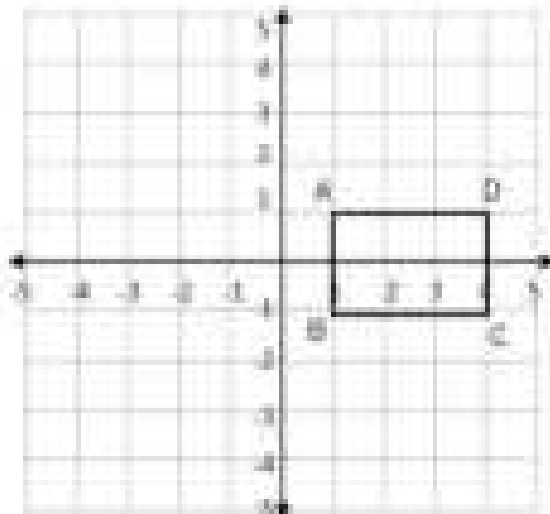

Mapping Rule: $(x + 4, y - 3)$

Name: _____

Translate the shape using the mapping rule.

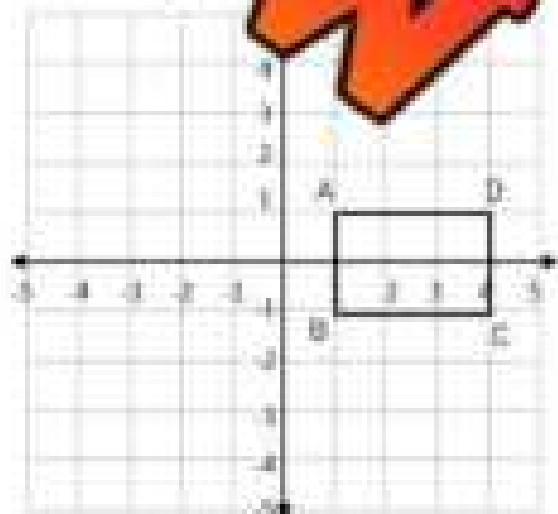

Mapping Rule: $(x + 4, y - 3)$

PREVIEW

Transformations - Translations

Instructions

1) Fill in the coordinates. 2) Describe the translation. 3) Translate shape C.

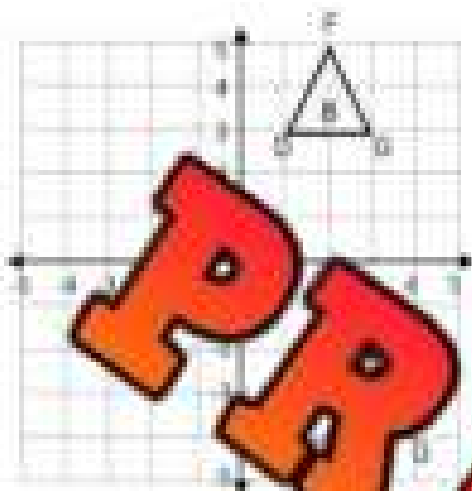

Coordinates A	Coordinates B
$D(\dots, \dots)$ $F(\dots, \dots)$ $G(\dots, \dots)$	$D(\dots, \dots)$ $F(\dots, \dots)$ $G(\dots, \dots)$
Mapping Rule $(x, y) \rightarrow (x, y) \rightarrow (x + a, y + b)$	
Translate Shape B to Shape C $(x - 4, y - 5)$	
Coordinates C	

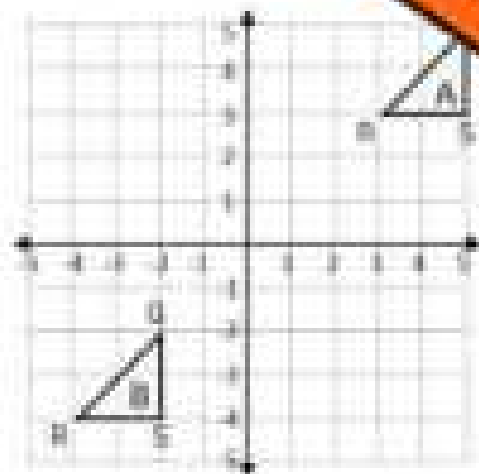

	Coordinates B
Mapping Rule $(x, y) \rightarrow (x + a, y + b)$	
Translate Shape B to Shape C $(x, y - 5)$	

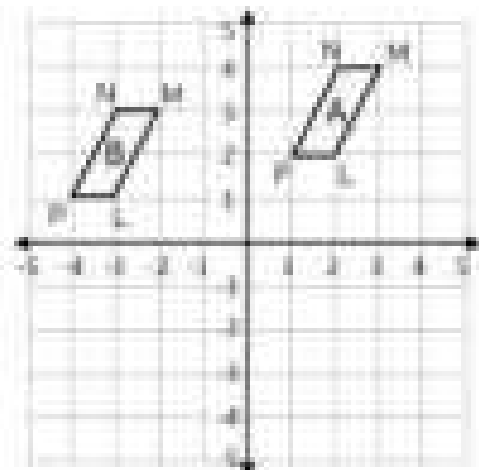

Coordinates A	Coordinates B
Mapping Rule $(x, y) \rightarrow (x, y) \rightarrow (x + a, y + b)$	
Translate Shape B to Shape C $(x + 4, y - 5)$	
Coordinates C	

Reflecting a Point Using a Mirror Line**Instructions**

Graph the new position of each point

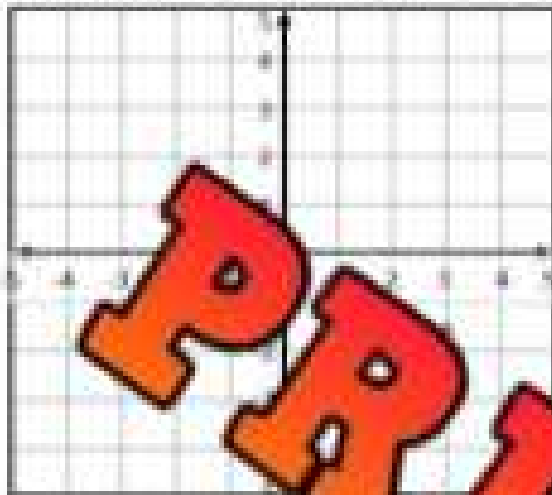
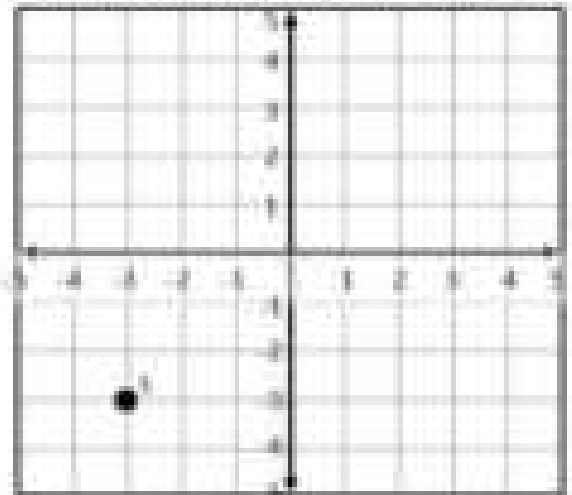
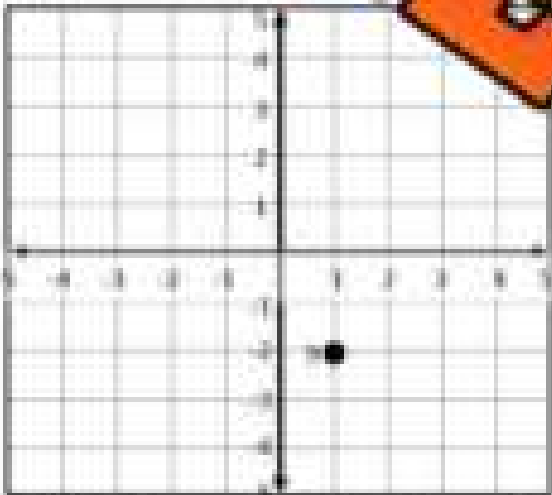
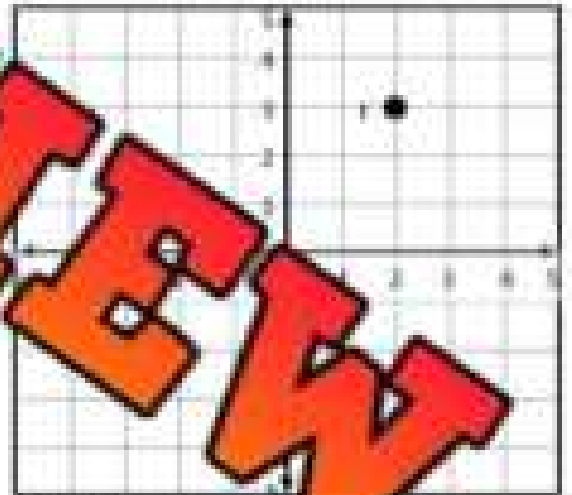
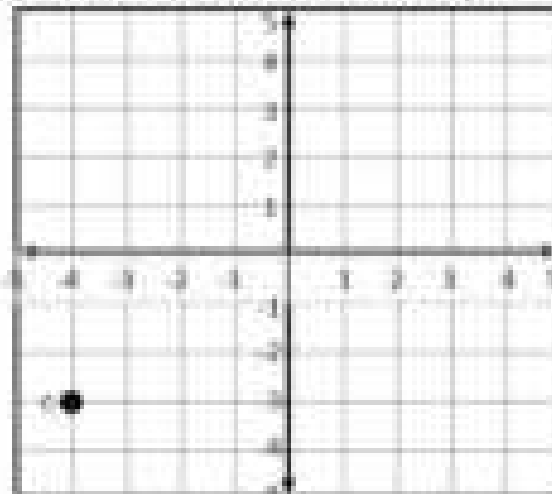
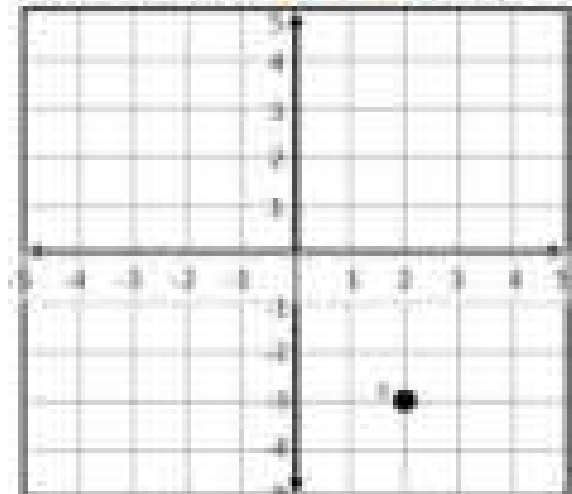
1) Reflection across the line $x = 1$ 2) Reflection across the line $y = -1$ 3) Reflection across the line $x = 1$ 4) Reflection across the line $x = -1$ 5) Reflection across the line $y = -1$ 6) Reflection across the line $y = -2$ 

Reflecting a Shape Using a Mirror Line

Instructions

Graph the new position of each shape after the given reflection

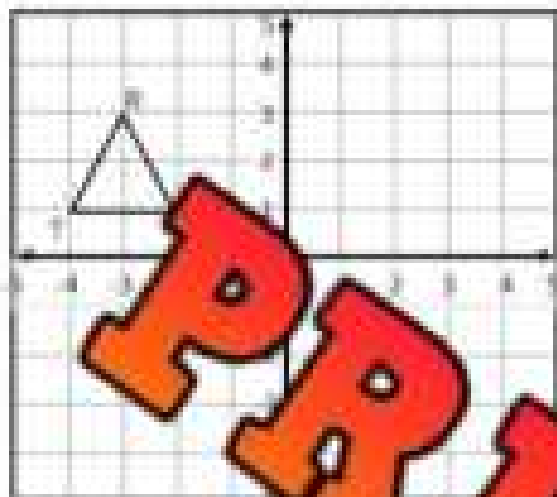
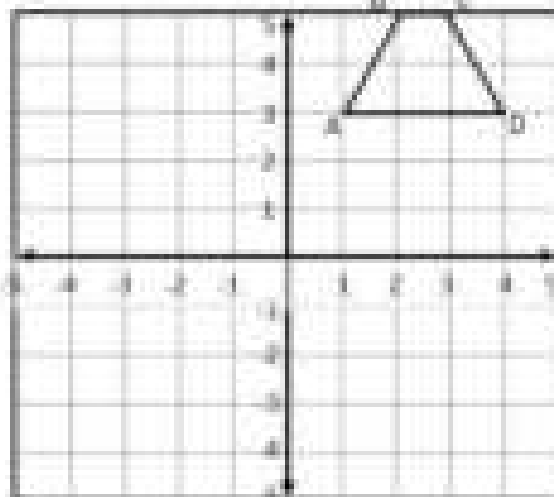
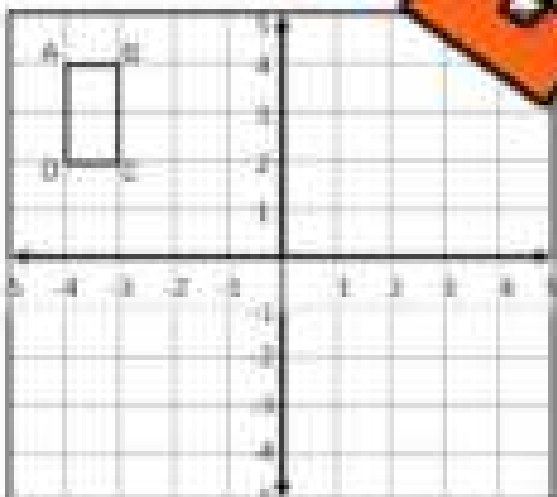
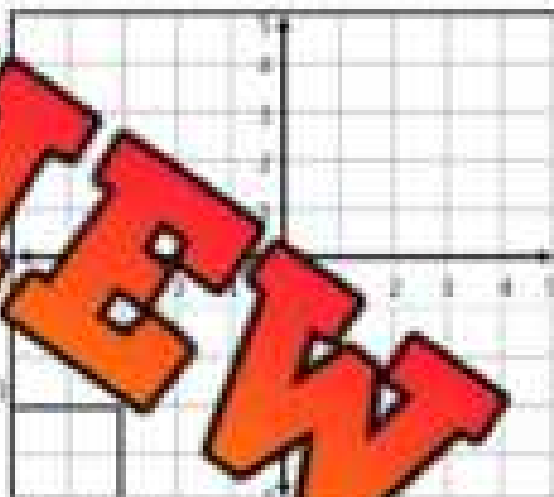
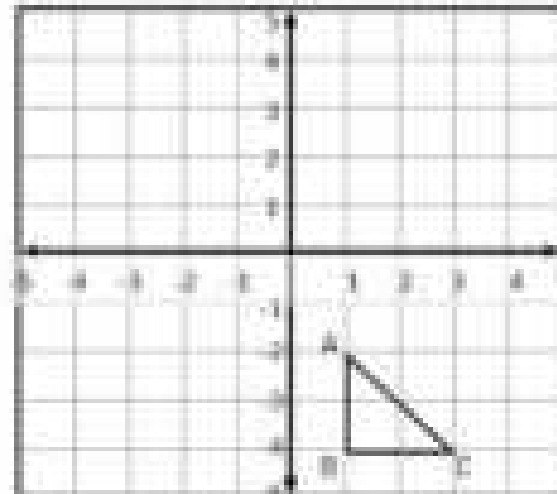
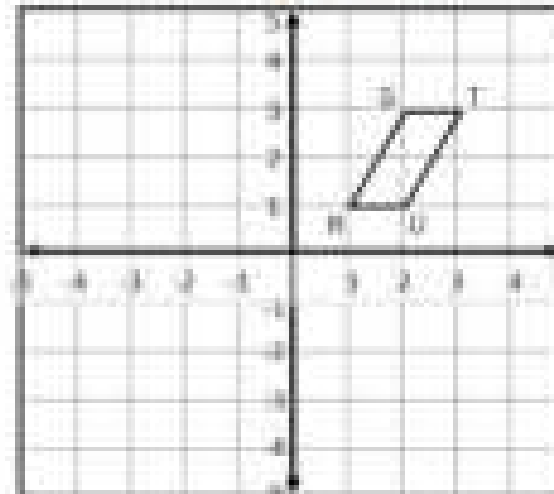
1) Reflection across the y -axis2) Reflection across the x -axis3) Reflection across the y -axis4) Reflection across the line $x = -1$ 5) Reflection across the line $y = -1$ 6) Reflection across the line $x = 1$ 

Exit Cards

Cut Out Cut out the exit cards below and have students complete them at the end of class.

Name: _____

Describe the rule for the reflection line

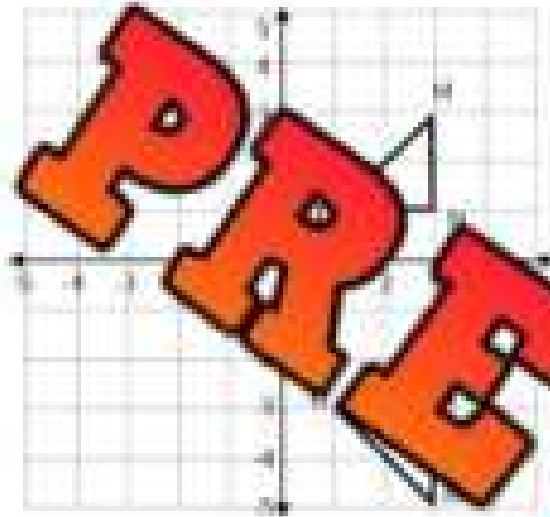

Answer: _____

Name: _____

Describe the rule for the reflection line

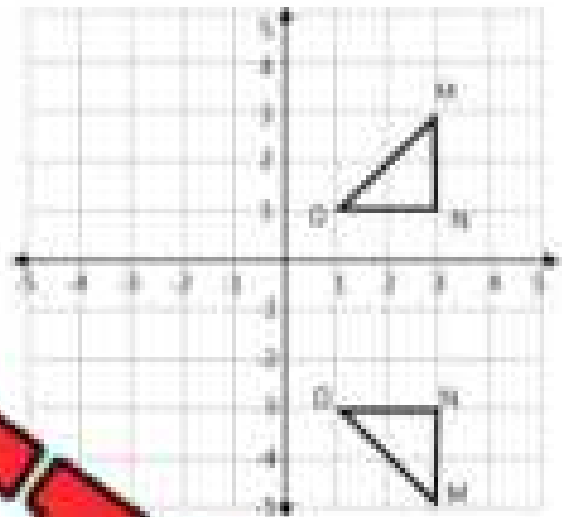

Answer: _____

Name: _____

Describe the rule for the reflection line

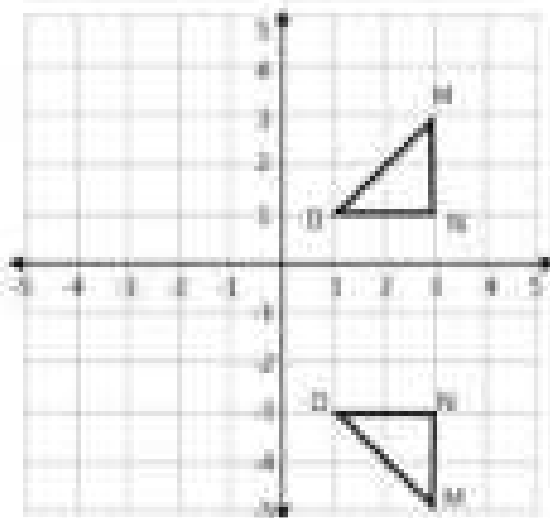

Answer: _____

Name: _____

Describe the rule for the reflection line

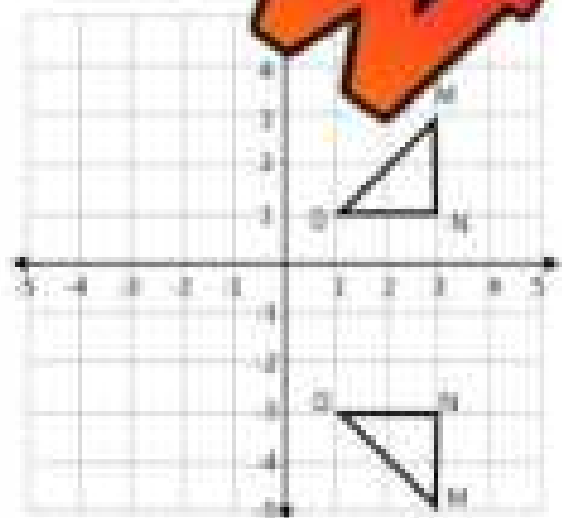

Answer: _____

Reflections – Mapping Rules

Mapping Rules for Reflections

Each point on a shape moves according to the mapping rule.

The rule for a reflected shape in the x -axis is $(x, y) \rightarrow (x, -y)$

The rule for a reflected shape in the y -axis is $(x, y) \rightarrow (-x, y)$

In the example of Shape A being reflected to Shape B, point F $(-3, -2)$ has been reflected across the x -axis, which means the new coordinates for F are $(-3, 2)$.

If Shape A is reflected across the y -axis to Shape C, point F becomes $(3, -2)$.

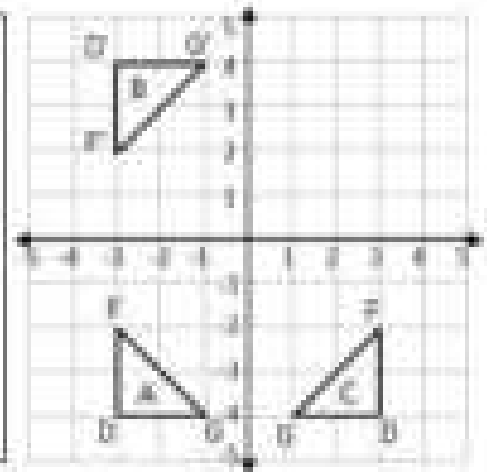

Instructions Use the mapping rules to write the new coordinates.

	Original Coordinates	Reflected across the	New Coordinates
1)	P(5, 4)	x -axis	P(-5, 4)
2)	S(8, -3)	y -axis	
3)	O(-6, 7)	x -axis	
4)	P(-4, -2)	y -axis	
5)	T(-5, 9) Y(-11, -15)	x -axis	
6)	S(-12, -3) R(7, 13)	x -axis	
7)	N(-4, 9) K(8, -17)	y -axis	
8)	P(13, -5) E(-6, 15)	x -axis	
9)	S(-18, -13) R(9, 14)	y -axis	
10)	N(-6, 11) K(7, -23)	x -axis	

Reflections – Coordinates

Part 1

Draw the shapes using the coordinates provided. Then reflect the shapes.

Shape A

$P(5,4), Q(3,7), R(3,3)$

Reflect over the x -axis

New Coordinates

$P(\quad, \quad), Q(\quad, \quad), R(\quad, \quad)$

$F(-4,-4), G(-4,-6)$

Reflect over the y -axis

New Coordinates

$F(\quad, \quad), G(\quad, \quad), H(\quad, \quad)$

Shape C

$J(-7,-4), K(-4,-9), L(-5,-3)$

Reflect over the y -axis

New Coordinates

$J(\quad, \quad), K(\quad, \quad), L(\quad, \quad)$

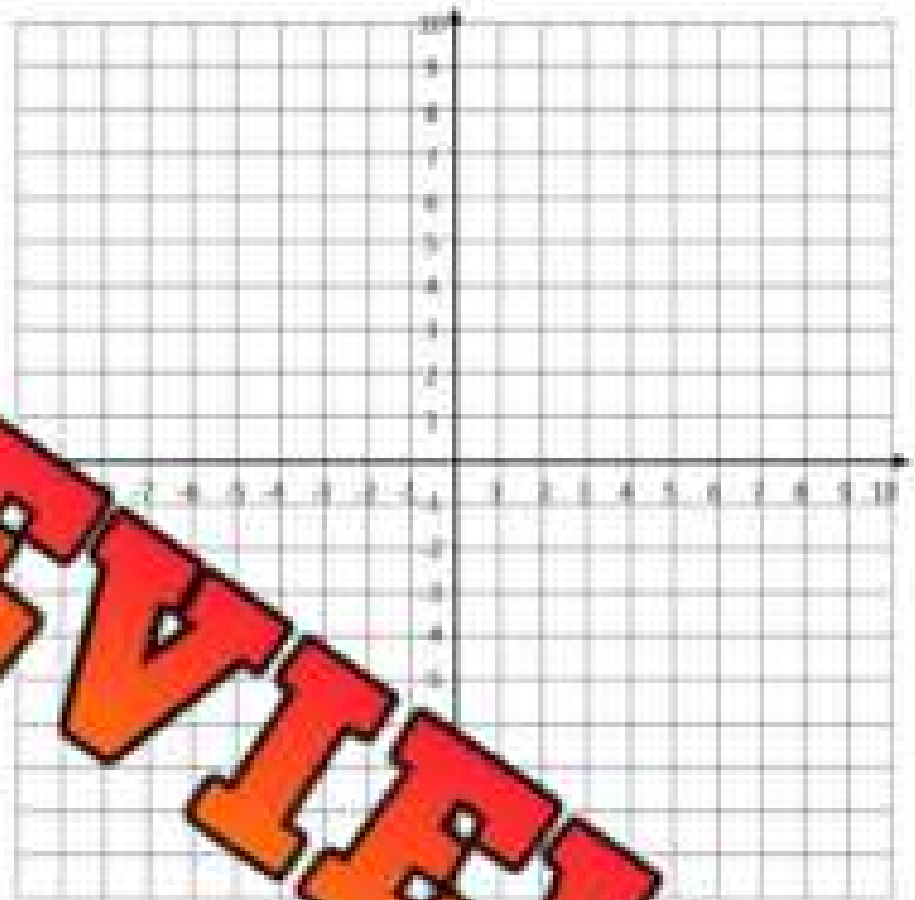

Part 2

Draw your own shape and then perform the reflection.

1) Reflection across the y -axis

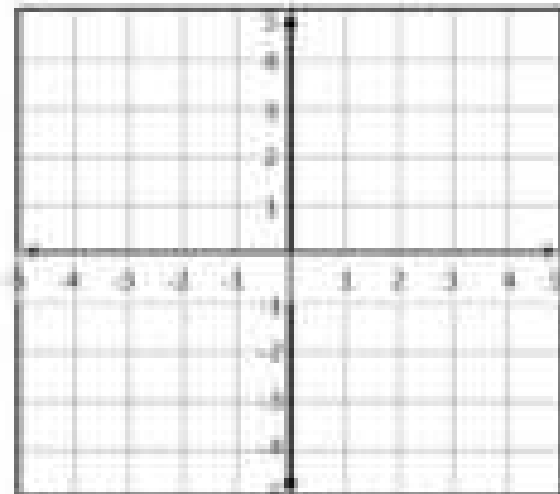

2) Reflection across the line $x = -1$

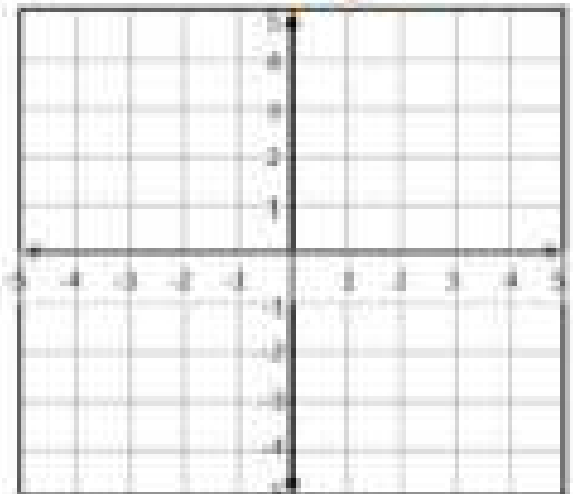

Exit Cards

Cut Out

Cut out the exit cards below and have students complete them at the end of class

Name: _____

Describe the rule for the reflection line

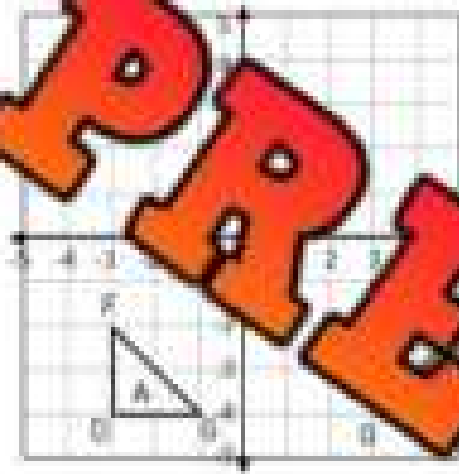

Name: _____

Describe the rule for the reflection line

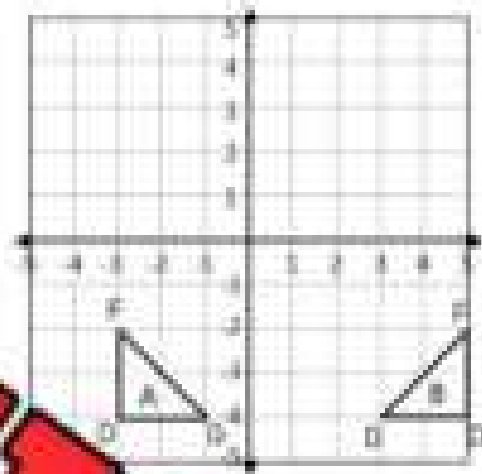

Name: _____

Describe the rule for the reflection line

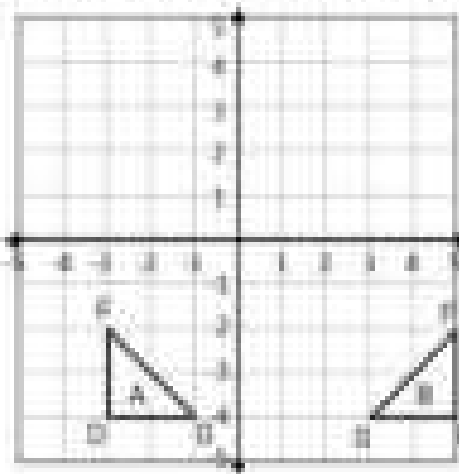

Name: _____

Describe the rule for the reflection line

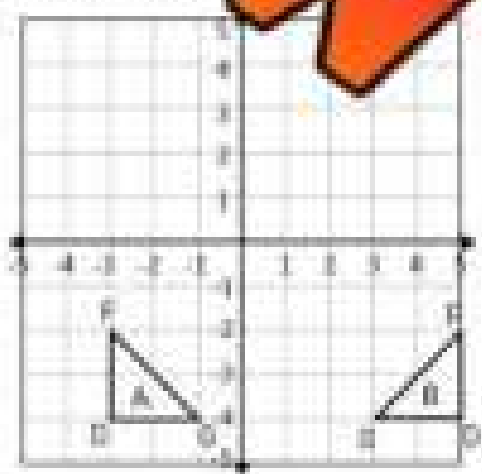

Rotating a Point

Mapping Rules for Rotations

Each point on a shape moves according to the mapping rule.

- a shape rotated 90° counterclockwise has a mapping rule of: $(x, y) \rightarrow (-y, x)$
- a shape rotated 180° counterclockwise has a mapping rule of: $(x, y) \rightarrow (-x, -y)$
- a shape rotated 270° counterclockwise has a mapping rule of: $(x, y) \rightarrow (y, -x)$

In the example, the shape was rotated 180° counter-clockwise in the first quadrant and rotated 90° clockwise.

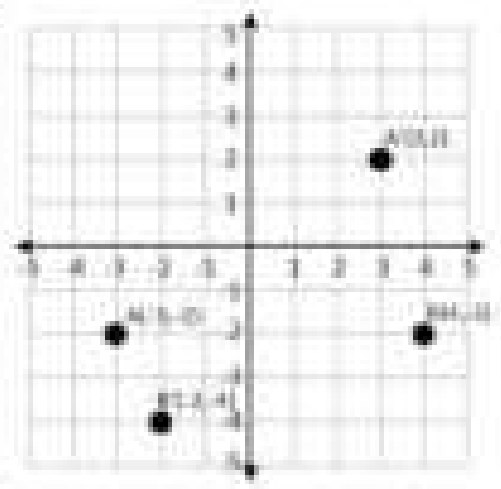

Instructions Draw the image of the point after rotating around the origin

1) 180° rotation

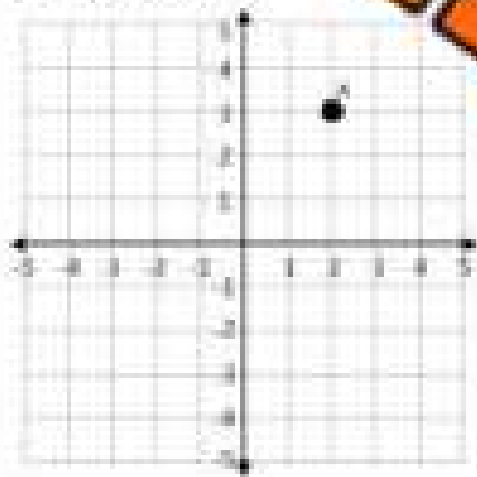

Original Coordinates
A(3 , 2)
Rotated Coordinates
A(-3 , -2)

2) 90° clockwise rotation

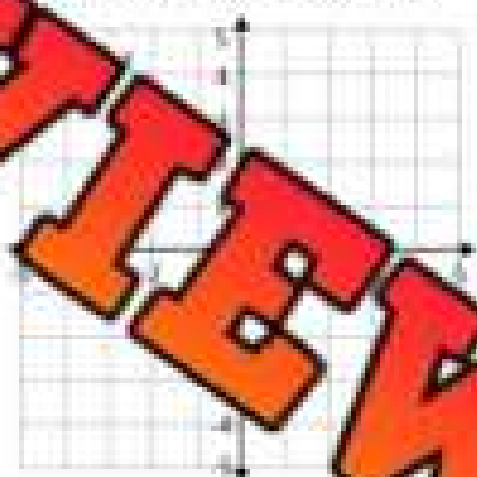

Original Coordinates
A(3 , 2)
Rotated Coordinates
A(2 , -3)

3) 90° counterclockwise rotation

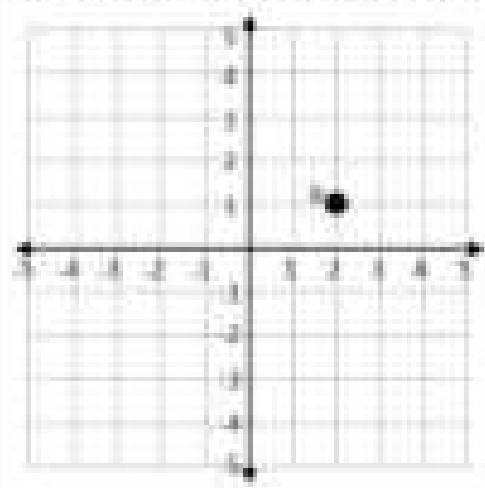

Original Coordinates
A(3 , 2)
Rotated Coordinates
A(-2 , 3)

4) 90° clockwise rotation

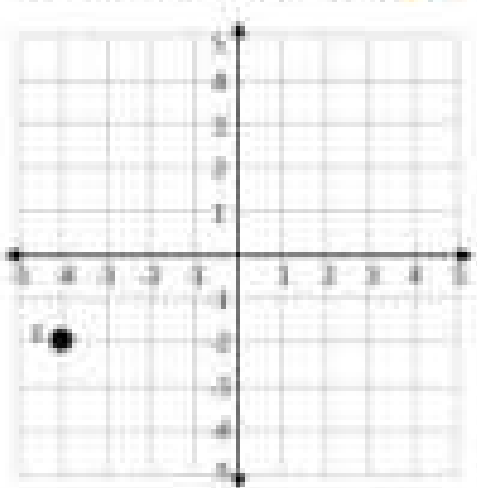

Original Coordinates
A(3 , 2)
Rotated Coordinates
A(2 , -3)

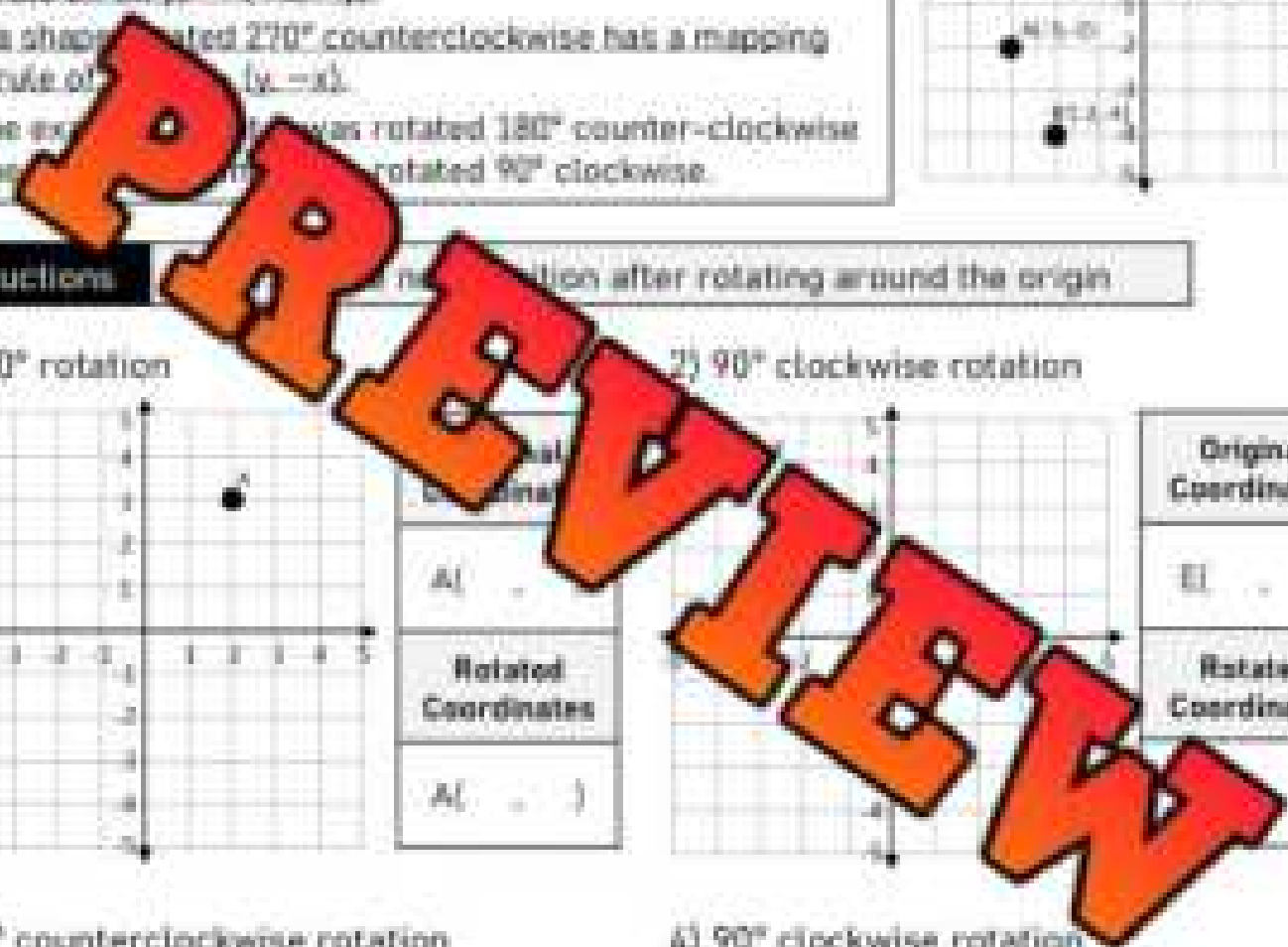

Rotating Shapes

Instructions

Graph the new position of each shape after the given rotation

1) 90° clockwise rotation

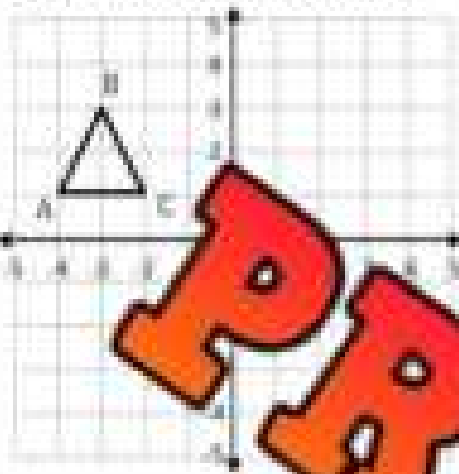

Original
Coordinates

A(. .)

B(. .)

C(. .)

Rotated
Coordinates

A(. .)

B(. .)

C(. .)

2) 90° counterclockwise rotation

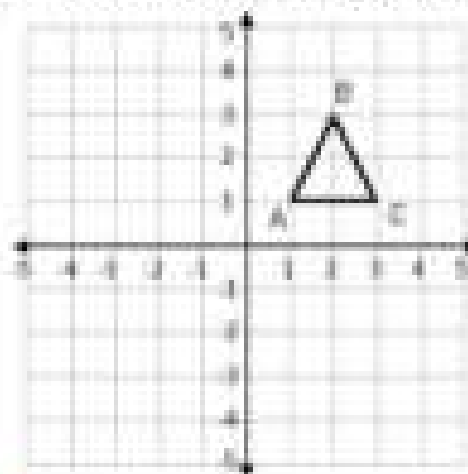

Original
Coordinates

A(. .)

B(. .)

C(. .)

Rotated
Coordinates

A(. .)

B(. .)

C(. .)

3) 180° rotation

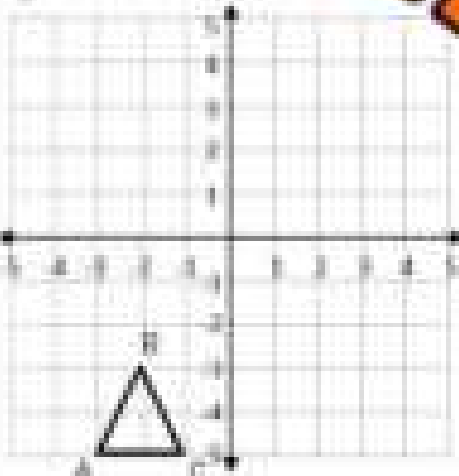

Original
Coordinates

A(. .)

B(. .)

C(. .)

Rotated
Coordinates

A(. .)

B(. .)

C(. .)

4) 70° clockwise rotation

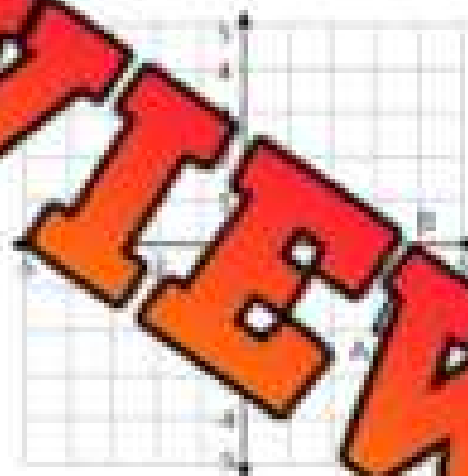

Original
Coordinates

A(. .)

B(. .)

C(. .)

Rotated
Coordinates

A(. .)

B(. .)

C(. .)

5) 90° clockwise rotation

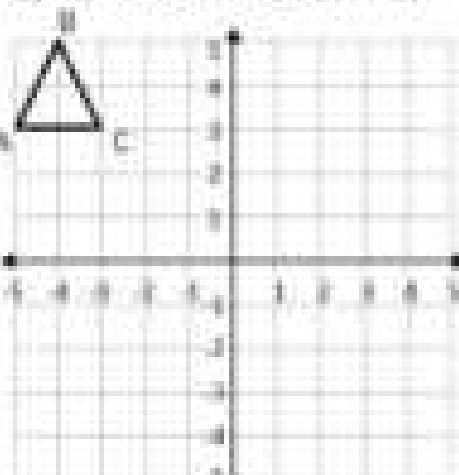

Original
Coordinates

A(. .)

B(. .)

C(. .)

Rotated
Coordinates

A(. .)

B(. .)

C(. .)

6) 90° counterclockwise rotation

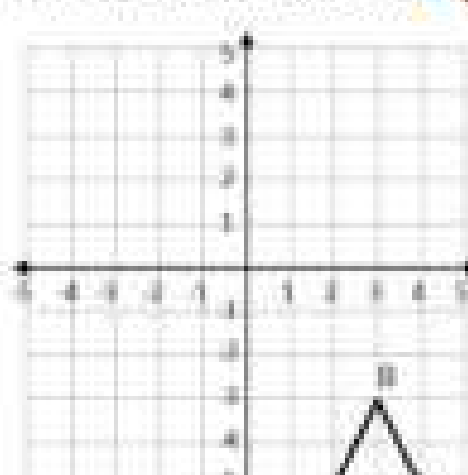

Original
Coordinates

A(. .)

B(. .)

C(. .)

Rotated
Coordinates

A(. .)

B(. .)

C(. .)

Rotations – Coordinates

Part 1 Draw the shapes using the coordinates provided. Then rotate the shape about the origin.

Shape A
P(8,4), Q(5,7), R(4,3)
90° counterclockwise rotation
New Coordinates
P(. , .), Q(. , .), R(. , .)

Shape B
F(10,-9), G(10,-5), H(12,-5)
180° rotation
New Coordinates
F(. , .), G(. , .), H(. , .)

Shape C
J(-1,-8), K(-4,-6), L(-1,-3)
270° counterclockwise rotation
New Coordinates
J(. , .), K(. , .), L(. , .)

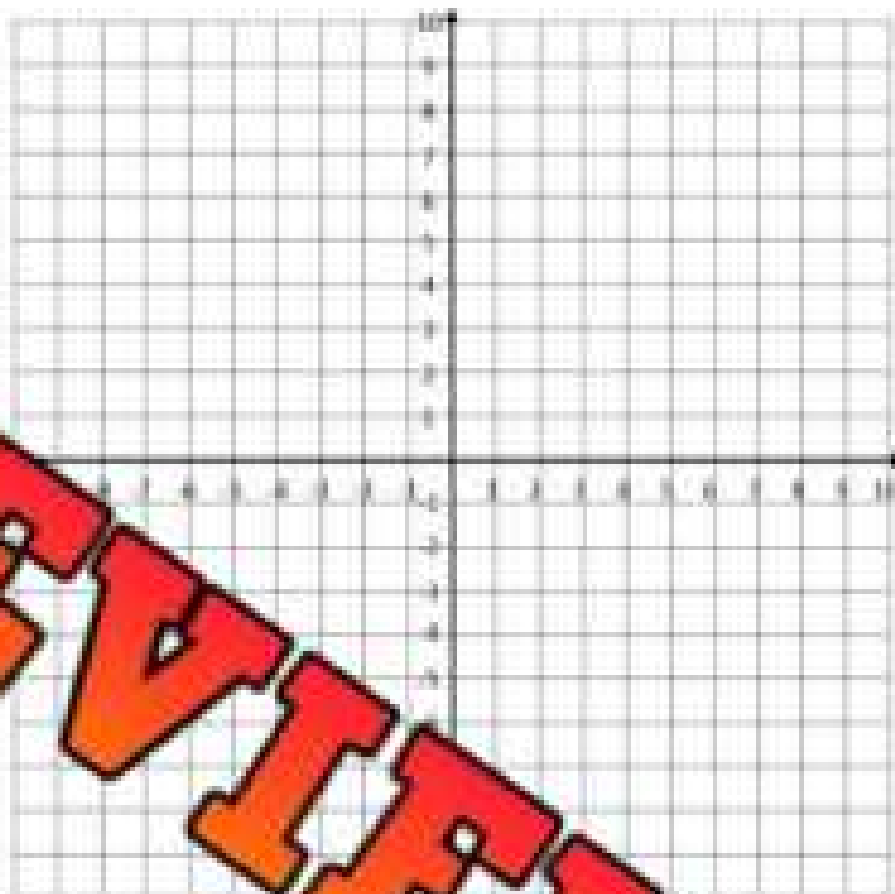



Part 2 Provide the coordinates of each point after the rotation.

	Original Coordinate	Rotations Across The Line...	New Coordinates
1)	P(5, 4)	90° counterclockwise rotation	P(-4, 5)
2)	S(3, -6)	180° rotation	
3)	Q(-4, 9)	360° rotation	
4)	P(-7, -11)	270° counterclockwise rotation	
5)	T(-5, 1) Y(-4, -7)	90° clockwise rotation	
6)	S(-7, -5) R(8, 2)	180° rotation	
7)	N(-5, 8) K(4, -9)	270° clockwise rotation	
8)	P(3, -5) E(-6, 2)	180° rotation	

Geometry Test

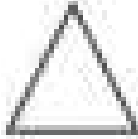
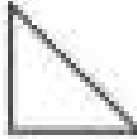
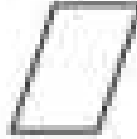

Part 1

Can the shapes below be used by themselves in a tessellation?

		
1) Yes No	2) Yes No	3) Yes No
		
	5) Yes No	6) Yes No

Part 2

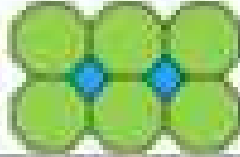
Write the type of tessellation for the examples below

Tessellation	Type of Tessellation (Regular, Semi-Regular, Irregular)
1) 	
2) 	
3) 	

Part 3

Draw a tessellation using the combination of polygons below.

Pentagon and Triangle	
-----------------------	--

Part 4

Look at the front, top, and side views and circle the matching 3D object

Top View	Front View	Side View

Top View	Front View	Side View

Part 5

Draw the isometric view of the letter. Use a scale of 1:1.

Letter	Front View	Isometric View
Y		

Part 6

Draw the top, front, and side views of the isometric drawing

Isometric View	Cavalier	Cabinet
<p>2)</p>		

Part 7

Fit your drawing on the grid by choosing an appropriate scale.

1) A garage door has the dimensions 225cm by 175cm.
Draw the garage door by determining the scale.

Scale = 1cm to _____

2) A street sign has the following dimensions: 88cm by 66cm.
Draw the sign by determining the scale.

Scale = 1cm to _____

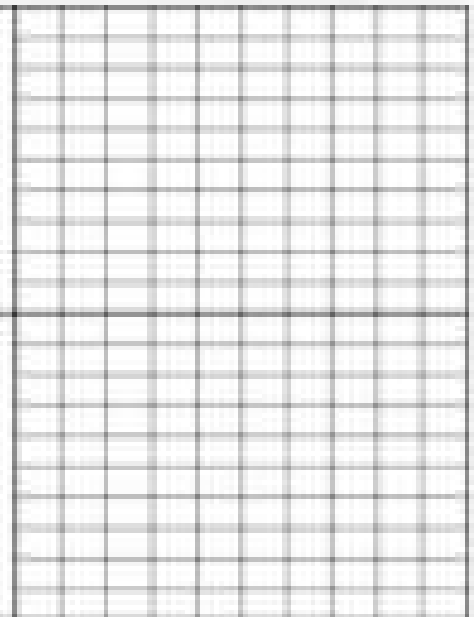

Part 8

Calculate the area of the original shape and the scaled drawing.

Original Shape	Scaled Drawing
1)  Area = _____	Scale Factor = 2 Area = _____
2)  Area = _____	Scale Factor = 4 Area = _____

Part 9

Give the coordinates of each point after the translation.

	Original Coordinate	Translation - Mapping Rule	New Coordinates
1)	P(3, -4)	$(x - 6, y + 4)$	P(-3, 0)
2)	S(-5, 8)	$(x + 3, y - 5)$	
3)	Q(-9, -5)	$(x + 2, y - 7)$	
4)	L(10, 5) P(-3, -8)	$(x - 5, y + 8)$	
5)	T(-8, 7) Y(-9, -5)	$(x + 8, y + 5)$	

Part 10

Graph the new position of each shape after the given reflection

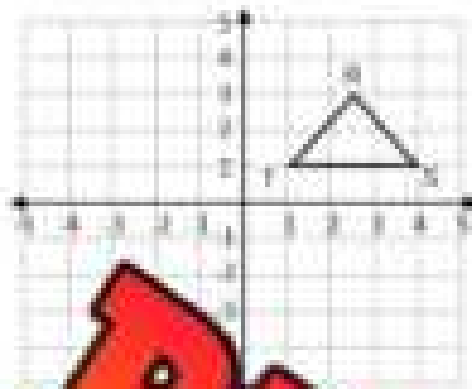
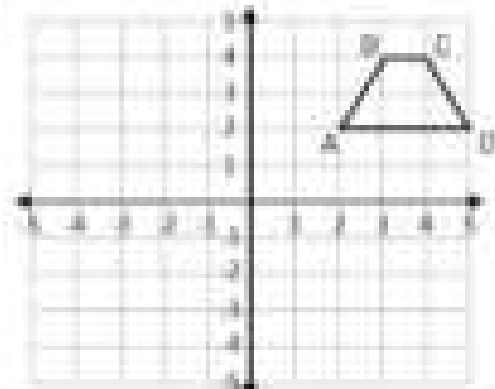
1) Reflection across the line $y = -1$ 2) Reflection across the line $x = 1$ 

Part 11

Graph the new position of each shape after the given rotation

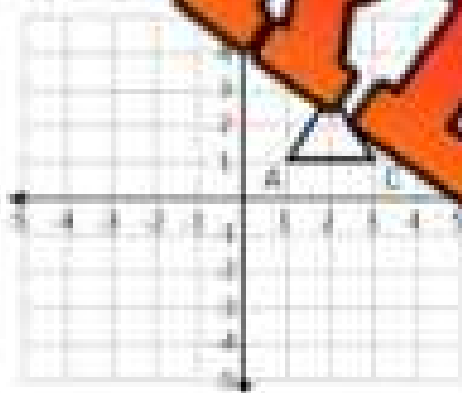
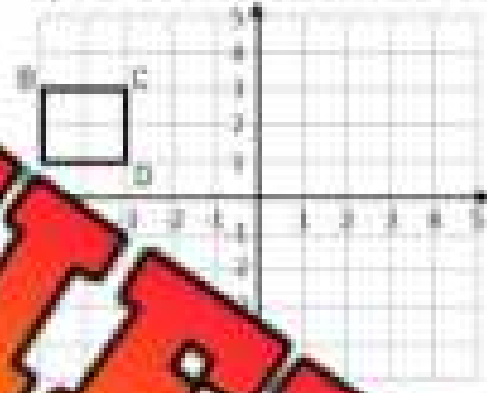
1) 270° clockwise rotation2) 90° counterclockwise rotation

Original	A(1, 1)	B(2, 1)	C(2, 2)
Rotated	A(. , .)	B(. , .)	C(. , .)

Original	A(1, 1)	B(2, 1)	C(2, 2)
Rotated	A(. , .)	B(. , .)	C(. , .)

Part 12

Draw the dilated shape on the grid

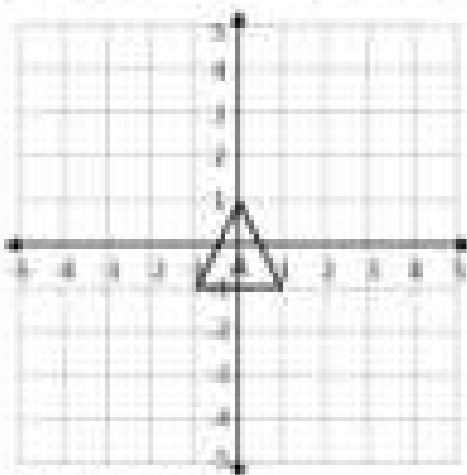
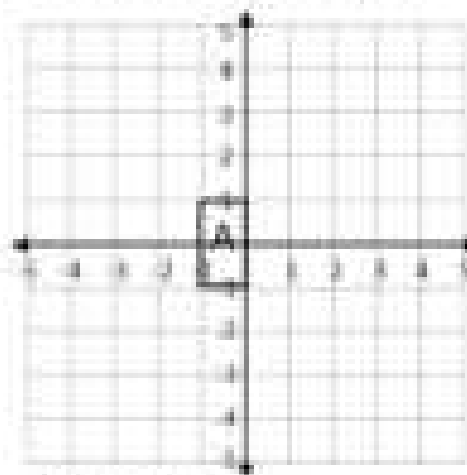
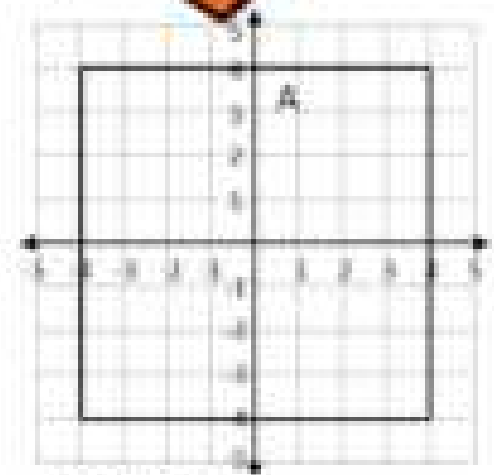
1) $k = 3$ 2) $k = 4$ 3) $k = \frac{1}{2}$

Grade 8

E2 – Measurement

	Curriculum Expectations	Pages That Cover the Expectations
E2.1	represent very large (mega, giga, tera) and very small (micro, nano, pico) metric units using models, base-ten relationships, and exponential notation	118 - 128
E2.2	solve problems involving angle properties, including the properties of intersecting and parallel lines and of polygons	129 - 150
E2.3	solve problems involving the perimeter, circumference, area, volume, and surface area of composite two-dimensional shapes and three-dimensional objects, using appropriate formulas	151 - 202
E2.4	describe the Pythagorean relationship using various geometric models, and apply the theorem to solve problems involving an unknown side length for a given right triangle	203 - 228

Converting Units - Ladder Method

We can use the ladder method to convert any metric unit of measurement to another simply by following the rules below.

Ladder Method

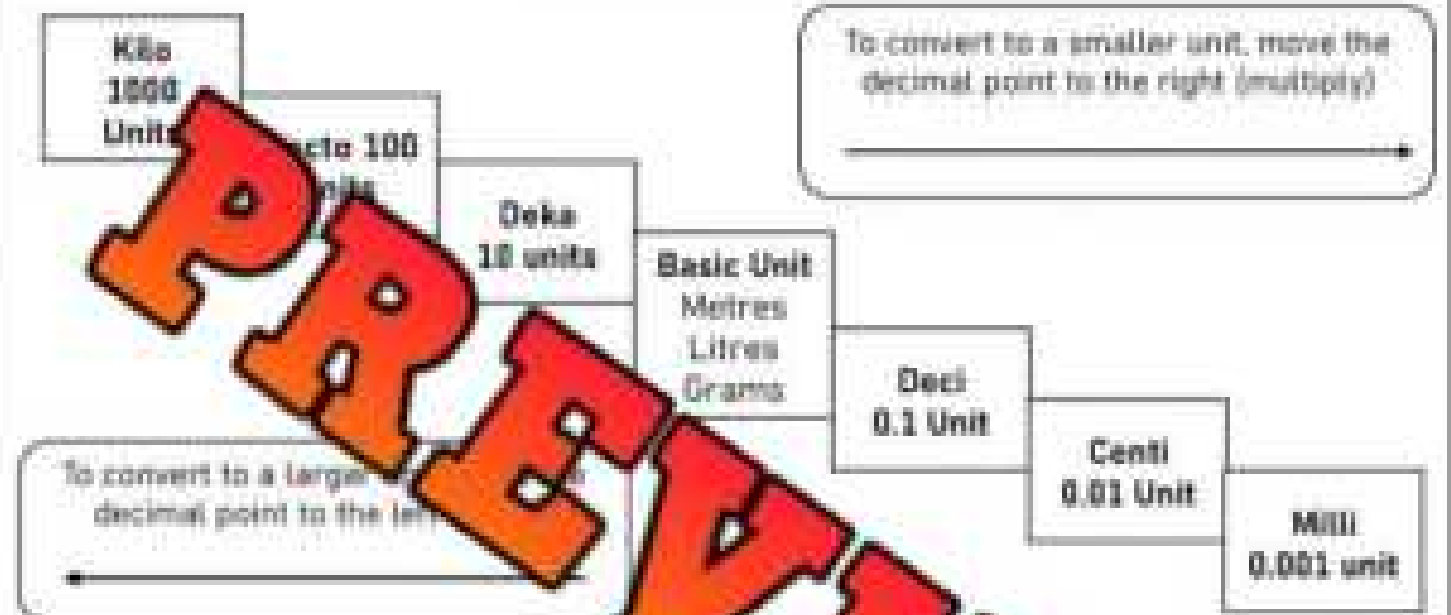

Instructions

1. Find your starting unit of measurement
2. Count the jumps to get to your ending unit of measurement
3. Move the decimal the number of jumps up or down
Moving Up = Left and Moving Down = Right

EXAMPLE

Convert 3.2 L to mL
 L to mL is 3 jumps down =
 Move the decimal 3 right)

Practice

Convert the units of measurement below

1) 3.8L _____ mL

5) 7.4kg _____ g

9) 723.3L _____ kL

2) 453mg _____ g

6) 954mg _____ g

10) 251.1kg _____ g

3) 1.32cL _____ mL

7) 231.7m _____ mm

11) 15.85m _____ km

4) 605.3m _____ km

8) 735.4mg _____ kg

12) 5243.2mL _____ kL

Large Metric Units – Mega, Giga, Tera

When we buy a hard-drive for a computer, they are sold based on their size. The first hard drive ever made was in 1956 and it held 5 megabytes. 5 megabytes is 5 000 000 bytes. In the year 2000, the best-selling hard drive was 8.4 gigabytes, which holds 8 400 000 000 bytes. Today, most hard drives hold over 1 terabyte. A terabyte holds 1,000,000,000,000. Although bytes are not part of the metric system, they are closely related and can help us remember the prefixes – mega, giga, and tera.



Instead of writing all the zeros, it is common to use exponents (scientific notation) to represent large numbers.

Part 1 Write the scientific notation of the numbers below

Number	Scientific Notation	Number	Scientific Notation
1) 15,000,000,000		6) 18 000 000 000 000	
2) 3 000 000		7) 303 000 000 000	
3) 82 000 000		8) 1 000 000 000 000	
4) 103 000 000 000		9) 75 000 000 000	
5) 7 000 000 000 000		10) 1 000 000 000 000	

Part 2 Fill in the table below using bytes as a unit.

Number of Bytes	Word Form	Mega, Giga, or Tera	Scientific Notation
1) 1 000 000 000	One-billion bytes	1 Gigabyte	1×10^9
2) 6 000 000			
3) 12 000 000 000			
4) 110 000 000 000			
5) 26 000 000 000 000			
6) 91 000 000 000 000			

Large Metric Units – Mega, Giga, Tera

Part 1

Fill in the tables below



Tg	Gg
1	
2	
3	
4	
5	
6	
7	
8	
9	
10	

Gm	Mm
1	
2	
3	
4	
5	
6	
7	
8	
9	

Part 2

Fill in the table below using metric units

Tera Metres	Giga Metres	Mega Metres
1		
2		
3		
4		
5		
6		
7		
8		
9		
10		

Very Small Units – Micro, Nano, Pico

Part 1

Fill in the table to learn more about the small metric units

Metric Prefix	Number of Units	Number	Scientific Notation
Base-unit	-1	1	1×10^0
Deci-unit (d)			
Centi-unit (c)			
Milli-unit (m)			
Kilo-unit (k)	1/1 000 000	0.000001	1×10^{-6}
Mega-unit (M)			
Giga-unit (G)			
Pico-unit (p)			

Part 2

Convert

To convert units, use the following steps:

- 1) Start with the first unit/number you are converting and use its scientific notation to find out its exponent – powers of 10. Example: 5cm has an exponent of -12
- 2) Determine the value of the exponent of the second unit you are converting to
- 3) Subtract the 2nd unit from the first
- 4) The answer you get will tell you how many times to move the decimal. If the number is positive, move the decimal place to the right. If it is negative, move the decimal left.

		Answer
1)	5cm → nm $(-2 - (-9) = 7)$	<u>50000000</u> nm
2)	2mm → μm	
3)	3000μg → cg	
4)	80000nL → μL	
5)	40cm → mm	
6)	750mm → μm	
7)	3000ng → mg	
8)	50cm → mm	
9)	4350μg → ng	
10)	820 nL → cL	

Converting Small and Large Metric Units

Part 1

Put the units in order from least to greatest

1) 5mm	40 000 μ m	520 000nm

2) 2 000kg	1Tg	400 000 000 μ g

3) 8 000 000L	5L	500 000mL

4) 25 000mm		25000m

5) 20 000 000ng	150g	200 0000 000pg

Part 2

Convert the units of measurement below

1) 500 000m	_____ Mm
-------------	----------

2) 50 μ m	_____ mm
---------------	----------

3) 1 000 000Mg	_____ Tg
----------------	----------

4) 11nL	_____ μ L
---------	---------------

5) 50 000 000 μ L	_____ μ L
-----------------------	---------------

6) 72m	_____ mm
--------	----------

7) 330m	_____ km
---------	----------

8) 25051kg	_____ Mg
------------	----------

9) 29.5gL	_____ kL
-----------	----------

10) 3cm	_____ μ m
---------	---------------

PREVIEW

Complementary Angles

Complementary Angles are two angles that add up to 90° . Therefore, the angles 40° and 50° are complementary angles because they add up to 90° . Together, complementary angles add up to make a right angle.

Example:



We can determine the missing complementary angle by subtracting the known angle from 90.



Practice Find the complementary angles.

1)

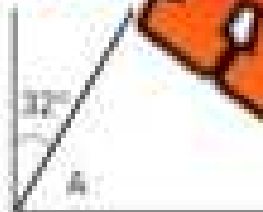

$$\angle A = \underline{\quad}^\circ$$

3)



$$\angle C = \underline{\quad}^\circ$$

4)



$$\angle A = \underline{\quad}^\circ$$

5)

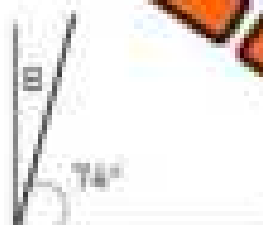

$$\angle B = \underline{\quad}^\circ$$

$$\angle C = \underline{\quad}^\circ$$

7)

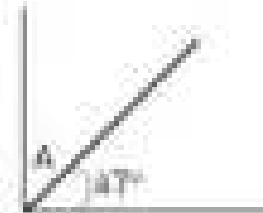

$$\angle A = \underline{\quad}^\circ$$

8)



$$\angle B = \underline{\quad}^\circ$$

9)



$$\angle C = \underline{\quad}^\circ$$

Supplementary Angles

Supplementary Angles are two angles that add up to 180° . You will notice that two supplementary angles make a straight angle of 180° .

Example:



We can determine the missing supplementary angle by subtracting the known angle from 180.



Prac: _____ the supplementary angles

1)



$$\angle A = \underline{\hspace{2cm}}^\circ$$

3)



$$\angle C = \underline{\hspace{2cm}}^\circ$$

4)



$$\angle A = \underline{\hspace{2cm}}^\circ$$

5)



$$\angle B = \underline{\hspace{2cm}}^\circ$$

6)



$$\angle C = \underline{\hspace{2cm}}^\circ$$

7)



$$\angle A = \underline{\hspace{2cm}}^\circ$$

8)



$$\angle B = \underline{\hspace{2cm}}^\circ$$

9)



$$\angle C = \underline{\hspace{2cm}}^\circ$$

Complementary and Supplementary Angles

Part 1 Analyze the angles below. Are they complementary, supplementary or neither?

1)



Original Angle

--	--	--

Original Angle

--	--	--

2)



Original Angle

--	--	--

Part 2 Fill in the table by writing in the complementary and supplementary angles.

Angle	Supplementary	Complementary	Angle	Supplementary	Complementary
12°			74°		
44°			26°		
81°			54°		

Complementary and Supplementary Angles

Part 1

Write the complementary angle for each angle below

#	Angle	Complementary
1	34°	
2	66°	
3		
4		

#	Angle	Complementary
5	31°	
6	74°	
7	87°	
8	25°	

Part 2

Are the given pairs of angles complementary? Yes or No?

#	Pair	Yes/No
1	$33^\circ, 57^\circ$	
2	$64^\circ, 36^\circ$	
3	$118^\circ, 62^\circ$	

#	Pair	Yes/No
4	$34^\circ, 56^\circ$	
5	$66^\circ, 34^\circ$	
6	49°	

Part 3

Write the supplementary angle for each angle below

#	Angle	Supplementary
1	143°	
2	151°	
3	137°	
4	112°	

#	Angle	Supplementary
5	71°	
6	165°	
7	103°	
8	114°	

Part 4

Are the given pairs of angles supplementary? Yes or No?

#	Pair	Yes/No
1	$134^\circ, 56^\circ$	
2	$47^\circ, 33^\circ$	
3	$112^\circ, 82^\circ$	

#	Pair	Yes/No
4	$166^\circ, 14^\circ$	
5	$58^\circ, 112^\circ$	
6	$123^\circ, 47^\circ$	

Introduction – Opposite Angles

Opposite angles are a pair of angles that are directly opposite to each other and are formed by two intersecting lines.



Angles A and B are opposite angles that are congruent, meaning they have the same angle measurement.

Angles C and D are also opposite angles which means they have the same angle measurements.

Part 1 Which angles are opposite in the two intersecting lines below?



_____ and _____
_____ and _____



_____ and _____
_____ and _____



_____ and _____
_____ and _____

Part 2 Which angles are opposite in the following diagrams?



_____ and _____
_____ and _____



_____ and _____
_____ and _____



_____ and _____
_____ and _____



_____ and _____
_____ and _____



_____ and _____
_____ and _____



_____ and _____
_____ and _____

Determining Angles Using Opposite and Supplementary Angles

Questions

Find the values of the unknown angle measurements.



A = 129°

B = 129°

C = 51°



A =

B =

C =



A =

B =

C =



A =

B =

C =

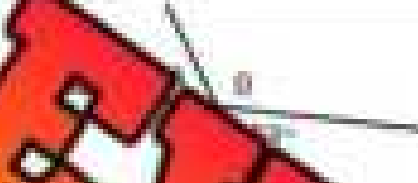

B =

C =



A =

B =

C =



A =

B =

C =



A =

B =

C =

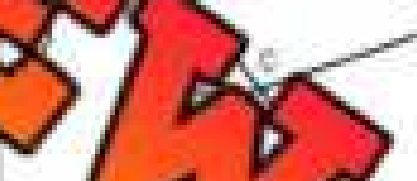

A =

B =

C =

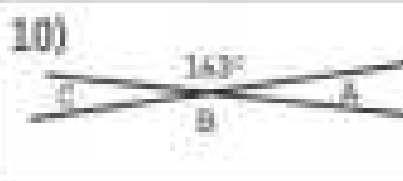

A =

B =

C =



A =

B =

C =



A =

B =

C =

Determining Angles Using Angle Properties

Questions

Find the values of the unknown angle measurements.



$A =$



$A =$ $E =$ $D =$



$E =$ $B =$ $D =$



$A =$ $H =$ $G =$



$A =$ $H =$ $G =$



$H =$ $G =$

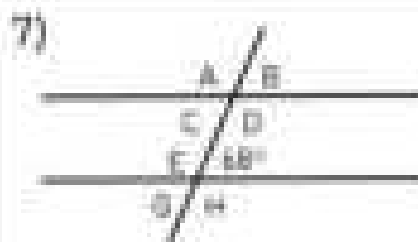

$C =$ $B =$ $A =$



$B =$ $D =$ $E =$



$D =$ $B =$ $G =$

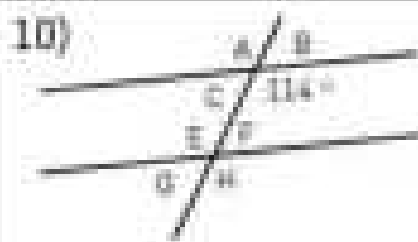

$H =$ $G =$ $B =$



$G =$ $F =$ $C =$

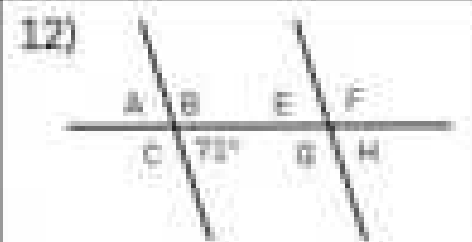

$A =$ $F =$ $H =$

Interior Angles - Quadrilaterals

Interior angles are the angles inside a shape. The interior angles of a quadrilateral will always equal 360° . We can use this information to solve for unknown angle measurements.



A rectangle has 4 equal angles that are 90° .

$$\begin{aligned} \angle A + \angle B + \angle C + \angle D &= 360 \\ 90 + 90 + 90 + 90 &= 360 \end{aligned}$$

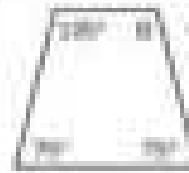

The trapezoid has 2 pairs of equal angles.

$$\begin{aligned} 75 + 75 + 100 + B &= 360 \\ B &= 105 \end{aligned}$$

Instructions: Find the values of the unknown angle measurements.

1)



A =



A =

3)



A =

4)

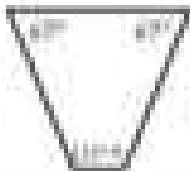

A =

5)



A =

A =

7)



A =

8)

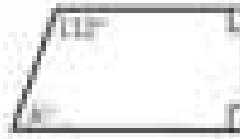

A =

9)



A =

10)



A =

11)



A =

12)



A =

Interior Angles - Quadrilaterals

Instructions

Find the values of the unknown angle measurements. No protractors!

1)



2)

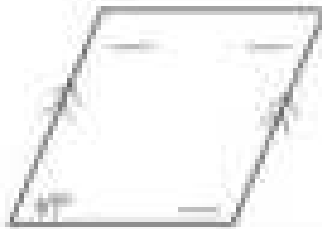

3)



4)

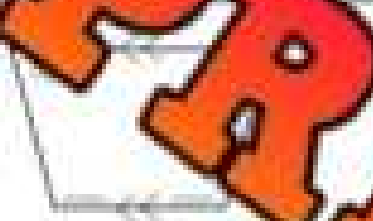

5)



6)

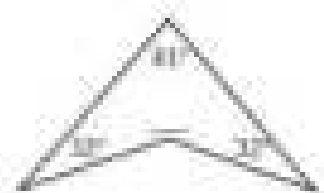

7)

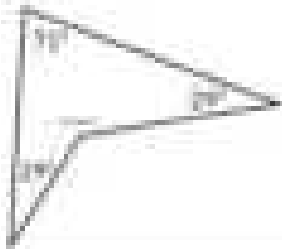

8)

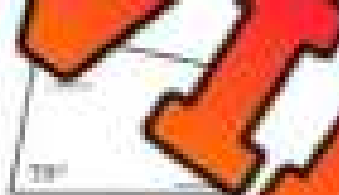

9)



10)



11)



12)

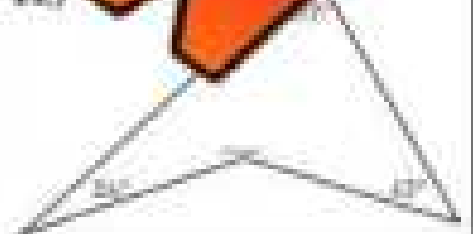

13)



14)



15)

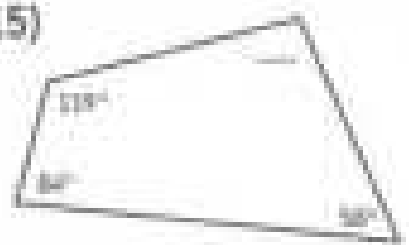

PREVIEW

Interior Angles - Polygons

We can determine the sum of interior angles for any polygon by using the following formula: $(n - 2) \times 180$ (n equals the number of sides on the polygon)

Substitute the number of sides the polygon has for the variable n .
For example - A triangle has 3 sides: $(3 - 2) \times 180 = 180^\circ$

Questions

Fill in the table below

#	# of Sides	Sum of Interior Angles	Regular Polygon Angle of Each Vertex
1)	3	$(n - 2) \times 180$ $(3 - 2) \times 180^\circ$ $180 = 180^\circ$	$\frac{180}{3} = 60^\circ$
2)	4		
3)	5		
4)	6		
5)	7		
6)	8		
7)	9		
8)	10		
9)	20		
10)	30		
11)	48		

Interior Angles - Polygons

Questions

Find the value of the unknown angle using the measurements provided

1)



2)



3)



4)



6)

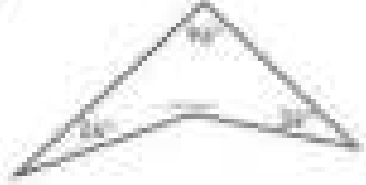

7)



8)



10)

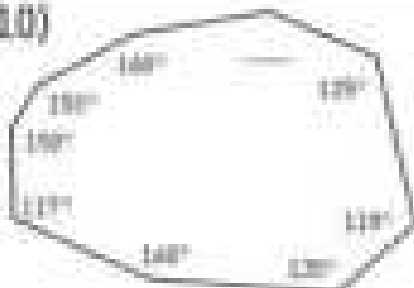

11)

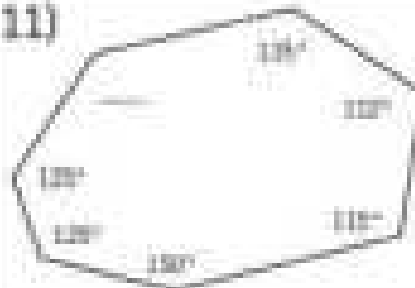

12)



PREVIEW

Unit Quiz – Metric System and Lines/Angles

Part 1

Fill in the tables below

Tg	Gg	Gm	Mm	μm	nm	ng	pg
1		1		1		1	
2		2		2		2	
3		3		3		3	
4		4		4		4	
5				5		5	
6				6		6	
7				7		7	
8				8		8	
9		9				9	
10		10				10	

Part 2

Put the units in order from least to greatest

1) 7mm	70 000 μm	70nm
2) 350 000kg	37g	370 000g

Part 3

Convert the units of measurement below

1) 500 000g	_____ Mg	2) 60 μm	_____ mm
3) 2 000 000Mg	_____ Tg	4) 3.1nL	_____ μL
5) 60 000 000 μL	_____ μL	6) 82m	_____ mm

Part 4

Write the complementary angle for each angle below

#	Angle	Complementary
1	37°	
2	63°	
3	84°	

#	Angle	Complementary
4	45°	
5	72°	
6	55°	

Part 5

Write the supplementary angle for each angle below

#	Angle	Supplementary
1	123°	
2	144°	
3	157°	

#	Angle	Supplementary
4	82°	
5	171°	
	106°	

Part 6

Find the values of the unknown angles in each diagram

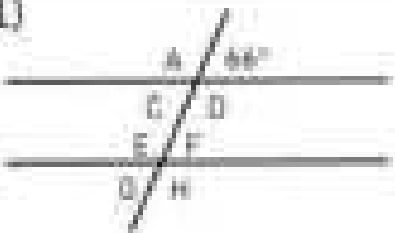
1) 

A = ___ H = ___ G = ___

2) 

A = ___ E = ___ D = ___

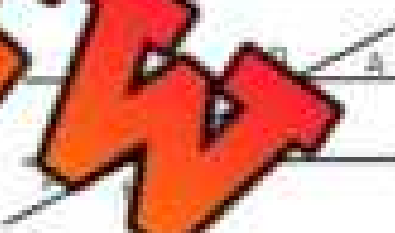
3) 

E = ___ B = ___ D = ___

4) 

A = ___ H = ___ G = ___

5) 

A = ___ F = ___ G = ___

6) 

A = ___ H = ___ G = ___





Part 7

Fill in the table below

#	Polygon - # of Sides	Sum of Interior Angles	Regular Polygon Angle of Each Vertex
1)	5		
2)	7		
3)			
4)			
5)	20		
6)	30		

Part 8

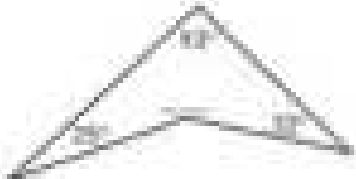
Find the values of the unknown

1) 	2) 	
A =	A =	A =
4) 	5) 	6) 

Area of Composite Polygons

Find the area of the polygons below by splitting them into separate shapes.

Example

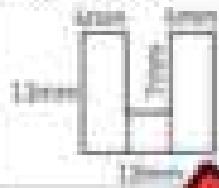

Area = area of rectangle 1 + area of rectangle 2 + area of rectangle 3

Rectangle 1:
 $A = 11 \times 12$
 $A = 132 \text{ mm}^2$

Rectangle 2:
 $A = 4 \times 4$
 $A = 16 \text{ mm}^2$

Rectangle 3:
 $A = 4 \times 11$
 $A = 44 \text{ mm}^2$

Area = $132 + 16 + 44$
 $A = 194 \text{ mm}^2$

Instructions

Find the area of the composite polygons below.

1)



Area = _____

2)

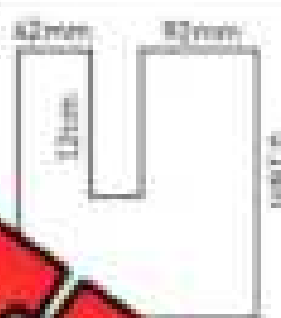

Area = _____

3)



Area = _____

4)



Area = _____

5)

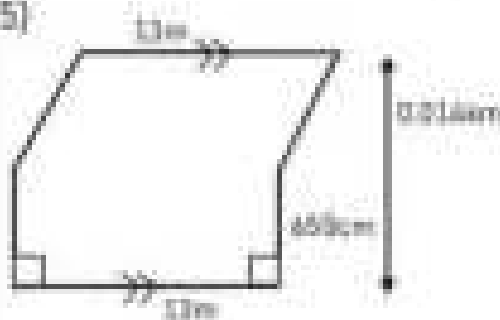

Area = _____

6)



Area = _____

Exit Cards

Cut Out

Cut out the exit cards below and have students complete them at the end of class

Name: _____

Find the area of composite shape



Area = _____

Name: _____

Find the area of composite shape

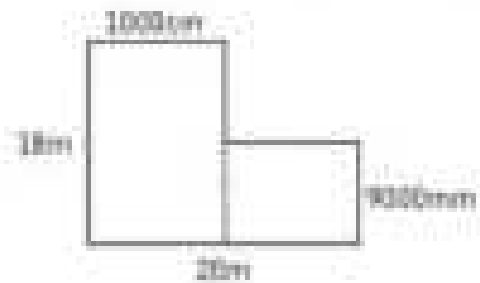

Name: _____

Find the area of



Area = _____

Name: _____

Find the area of composite shape



Area = _____

Calculating Radius and Diameter

Calculating Radius Formula

$$r = \frac{d}{2} \quad \text{or} \quad r = d \div 2$$

Calculating Diameter Formula

$$d = 2r \quad \text{or} \quad d = r \times 2$$

Instruction

Find the radius and diameter of each circle below

1)



Radius = _____

Diameter = _____

2)

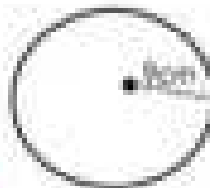

3)

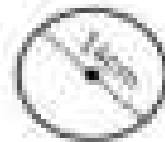

Radius = _____

Diameter = _____

4)

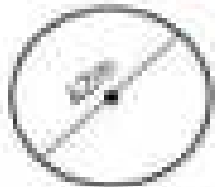

Radius = _____

Diameter = _____

5)



Radius = _____

Diameter = _____

6)

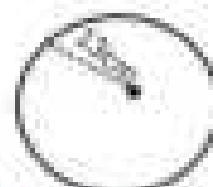

Radius = _____

Diameter = _____

7)

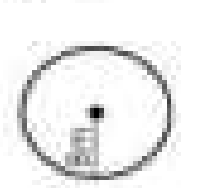

Radius = _____

Diameter = _____

8)

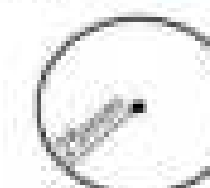

Radius = _____

Diameter = _____

9)



Radius = _____

Diameter = _____

10)



Radius = _____

Diameter = _____

11)

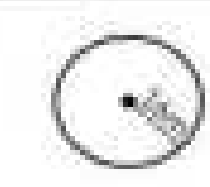

Radius = _____

Diameter = _____

12)

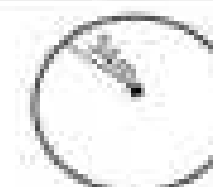

Radius = _____

Diameter = _____

PREVIEW

Calculating Circumference

Calculating Circumference (Diameter)

$$c = \pi d \quad \text{or} \quad c = \pi \times d$$

Calculating Circumference (Radius)

$$c = 2\pi r \quad \text{or} \quad c = 2 \times \pi \times r$$



Part 1

Fill in the table with the missing information

	Radius	Diameter	Circumference
1)	9cm		
2)			
3)		25m	
4)		48cm	
5)	7m		
6)			
7)	3.8km		
8)	8.5m		
9)			
10)		54.8	

Part 2

Answer the word problems below

1)	<p>Aden is deciding which pizza to buy. He has two options.</p> <p>Option A: Pizza with a radius of 22cm</p> <p>Option B: Pizza with a circumference of 136cm</p> <p>Which pizza is larger?</p>	
2)	<p>You need to wrap a label around a can. If the diameter of the can is 11.5cm, what length does the label need to be?</p>	
3)	<p>Alexa needs to wrap a cake she made with a ribbon. The cake has a radius of 16.25cm. How long does the ribbon need to be?</p>	

Exit Cards

Cut Out Cut out the exit cards below and have students complete them at the end of class.

Name: _____

1) Fill in the table with the missing information. ($c = \pi d$ & $c = 2\pi r$)

	Radius	Diameter	Circumference
1)	13		
2)		39m	
3)	11m		
4)		77m	

2) A circular garden has a radius of 7.5 m. You want to put a fence around the entire garden. How long does the fence need to be?

Name: _____

1) Fill in the table with the missing information. ($c = \pi d$ & $c = 2\pi r$)

	Radius	Diameter	Circumference
1)	13m		
2)		39m	
3)	11m		
4)		77m	

2) A circular garden has a radius of 7.5 m. You want to put a fence around the entire garden. How long does the fence need to be?

Name: _____

1) Fill in the table with the missing information. ($c = \pi d$ & $c = 2\pi r$)

	Radius	Diameter	Circumference
1)	13m		
2)		39m	
3)	11m		
4)		77m	

2) A circular garden has a radius of 7.5 m. You want to put a fence around the entire garden. How long does the fence need to be?

Name: _____

1) Fill in the table with the missing information. ($c = \pi d$ & $c = 2\pi r$)

	Radius	Diameter	Circumference
1)	13m		
2)		39m	
3)	11m		
4)		77m	

2) A circular garden has a radius of 7.5 m. You want to put a fence around the entire garden. How long does the fence need to be?

Area of a Circle - Radius

The area of a circle is the part inside the circle. We can calculate the area of a circle by using its radius. For most calculations, we can use 3.14 for pi. The formula is $\pi \times \text{radius}^2$. We can write this as $a = \pi r^2$.

Calculating Area Using Radius

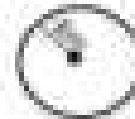

$$a = \pi r^2$$

$$a = \pi \times 8 \times 8$$

$$a = 200.96\text{m}^2$$

Practice

Calculate the area of the circles using the radius.

1)

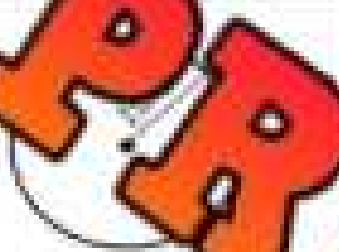

Radius = _____

Area = _____

2)



Area = _____

3)

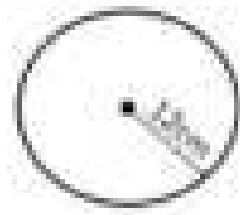

Radius = _____

Area = _____

4)

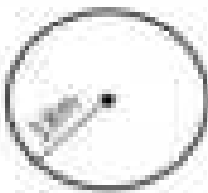

Radius = _____

Area = _____

5)



Radius = _____

Area = _____

6)



Radius = _____

Area = _____

7)

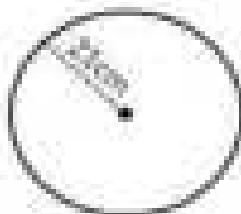

Radius = _____

Area = _____

8)

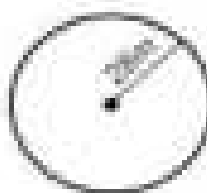

Radius = _____

Area = _____

9)

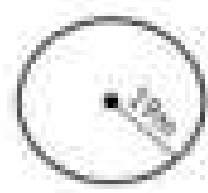

Radius = _____

Area = _____

Circles – Mixed Review

Practice

Fill in the blanks below

1)



Radius = _____

Diameter = _____

Circumference = _____

Area = _____

2)



Radius = _____

Diameter = _____

Circumference = _____

Area = _____

3)



Radius = _____

Diameter = _____

Circumference = _____

Area = _____

4)



Radius = _____

Diameter = _____

Circumference = _____

Area = _____

4)



Radius = _____

Diameter = _____

Circumference = _____

Area = _____

7)



Radius = _____

Diameter = _____

Circumference = _____

Area = _____

8)



Radius = _____

Diameter = _____

Circumference = _____

Area = _____

9)



Radius = _____

Diameter = _____

Circumference = _____

Area = _____

PREVIEW

Math Race: Circumference, Radius, Diameter, and Area**Objective**

What are we learning about?

Students will practice calculating the circumference, radius, diameter, and area of circles by quickly answering related questions in a competitive and engaging game format. They will learn how to estimate these values using $\pi \approx 3$.

Materials

What you will need for the activity

- A circle (circumference, radius, diameter, and area)
- Optional: Timer
- Chairs arranged in a circle

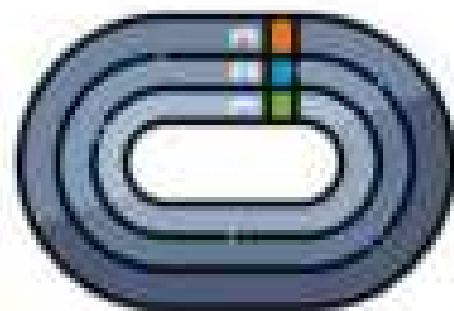
**Instructions**

How to complete the activity

1. **Setup:** Arrange chairs in a circle, with one student seated in a chair. One student stands behind a seated student to start the game.
2. **Explain the Game:** Explain to the students that they will be competing in a race around the circle by answering questions about circumference, diameter, and area. The goal is to move around the entire circle and return to their original position. Students should use mental math and estimation.
3. **Start the Game:** The teacher reads out a question (e.g., "What is the circumference of a circle with a radius of 3 cm?").
4. **Answering the Question:** The standing student and the seated student compete to answer the question first. The student who answers correctly first moves to stand behind the next seated student, while the other student remains seated.
5. **Continue the Race:** The teacher continues reading out questions, and the process repeats. The standing student continues to move around the circle, answering questions at each stop.
6. **Winning the Game:** The first student to make it around the entire circle and return to their original position wins the race.
7. **Review:** After the game, review some of the questions and answers with the class to reinforce the concepts and ensure understanding.

Questions

Use the questions below for the game

A cylindrical can has a circumference of 30 cm at its base. What is the can's diameter?	10 cm
A round placemat has a radius of 12 cm. What is the circumference of the placemat?	72 cm
The area of a circular fountain is 27 square metres. What is the diameter of the fountain?	6 metres
A round playground has a circumference of 48 metres. What is the radius of the playground?	8 metres
The area of a circular playground is 300 square metres. What is the radius of the playground?	10 metres
The area of a circular clock face is 12 square metres. What is the radius of the clock face?	2 metres
A round wall clock has a diameter of 18 cm. What is the circumference of the clock face?	90 cm
A circular pizza pan has a circumference of 20 cm. What is the radius of the pan?	10 cm
A circular garden plot has a radius of 4 metres. What is the circumference of the plot in centimetres?	240 cm
A round clock's face has a diameter of 16 cm. What is the area of the clock's face?	192 cm ²
The area of a circular trampoline is 75 square metres. What is the trampoline's diameter?	10 metres
A cylindrical water tank has a circumference of 150 cm at its base. What is the radius of the base?	12 cm
A round hot tub has a radius of 3 metres. What is the area of the hot tub in square centimetres?	2,700 cm ²
The diameter of a circular sticker is 9 cm. Calculate the circumference of the sticker.	27 cm
A circular track has a circumference of 60 metres. What is the radius of the track?	10 metres
The area of a round park bench is 300 square centimetres. Find the radius of the bench.	10 cm
A circular plate has a circumference of 30 cm. What is the plate's diameter?	10 cm
A round fountain has a diameter of 12 metres. Calculate the area of the fountain in square metres.	108 m ²

Perimeter of Composite Shapes

Questions

Find the perimeter of each composite shape

1)



Perimeter: _____

2)



Perimeter: _____

3)

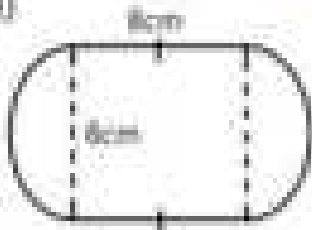

Perimeter: _____

4)



Perimeter: _____

5)

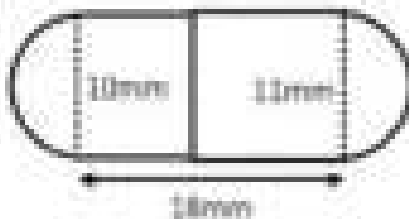

Perimeter: _____

6)

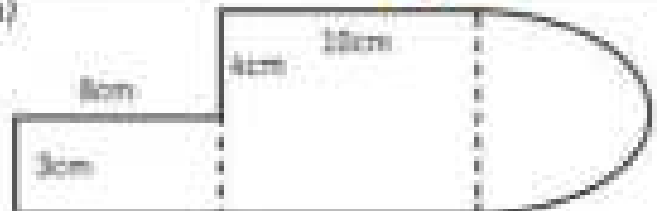

Perimeter: _____

Area of Composite Shapes

Questions

Find the area of each composite shape

1)

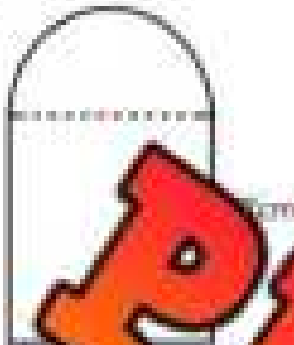

Area: _____

2)

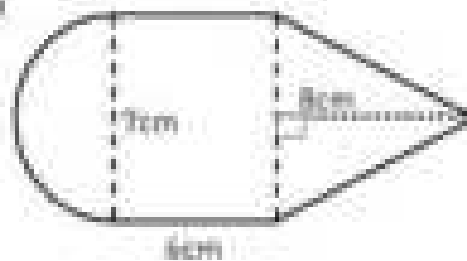

Area: _____

3)

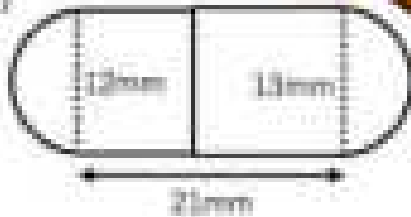

Area: _____

4)

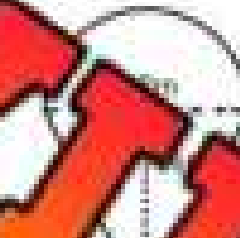

Area: _____

5)

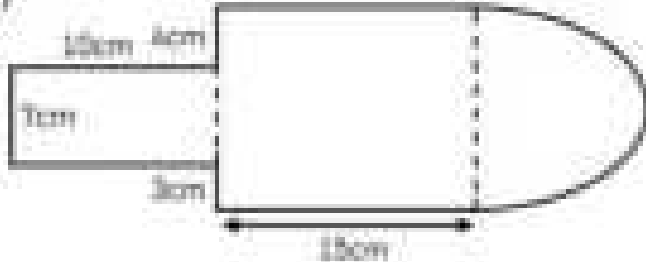

Area: _____

6)

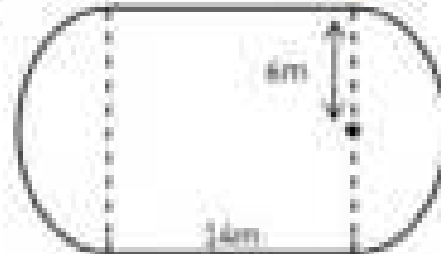

Area: _____

PREVIEW

Surface Area - Cylinders**Questions**

Solve the questions below

1)



Surface Area: _____

2)

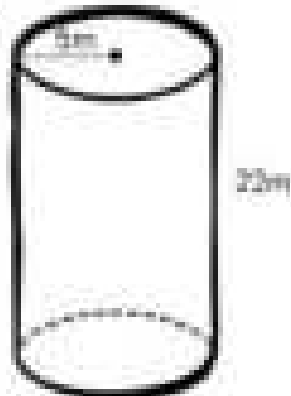

Surface Area: _____

3)

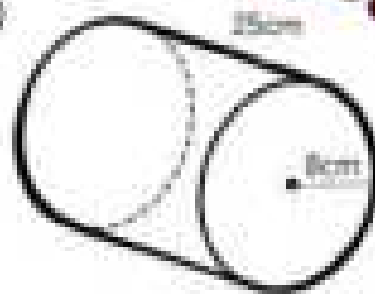

Surface Area: _____

3.5cm



Surface Area: _____

5)



Surface Area: _____

6)

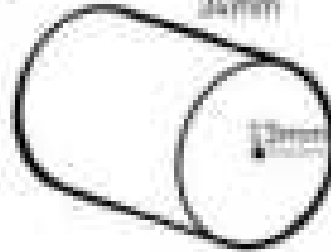

Surface Area: _____

Surface Area - Cylinders

Instruction

Solve the questions below

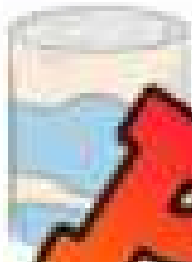

1) A can of soup has a diameter of 9cm and a height of 19cm. What is the surface area of the can?

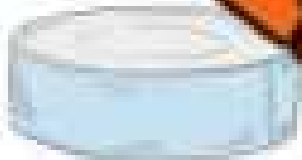

2) A can of tuna has a radius of 7.5cm and a height of 42mm. What is the surface area of the can?



3) A battery is composed of cylinders. The main battery cylinder has a radius of 1.5cm and a height of the main cylinder is 8cm. The smaller cylinder on top of the battery has a diameter of 8mm. What is the surface area of the battery?

What is the total surface area of the battery?



4) A barrel has a diameter of 74cm and a height of 1.62m. What is the surface area of the barrel?

Exit Cards

Cut Out

Cut out the exit cards below and have students complete them at the end of class.

Name: _____

1) Solve the questions below



2) A soda can is modeled as a cylinder with a radius of 6 cm and a height of 15 cm. Draw its net and calculate the surface area of the can.

Name: _____

1) Solve the questions below

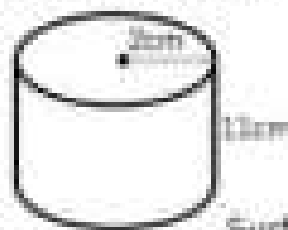

Surface Area: _____

2) A soda can is modeled as a cylinder with a radius of 6 cm and a height of 15 cm. Draw its net and calculate the surface area of the can.

Name: _____

1) Solve the questions below



Surface Area: _____

2) A soda can is modeled as a cylinder with a radius of 6 cm and a height of 15 cm. Draw its net and calculate the surface area of the can.

Name: _____

1) Solve the questions below



Surface Area: _____

2) A soda can is modeled as a cylinder with a radius of 6 cm and a height of 15 cm. Draw its net and calculate the surface area of the can.

Surfaces Area Using Nets - Cylinders

Instruction

Solve the questions below.

1) A toilet paper roll is 16cm tall with a radius of 5cm. The inside cylinder is a hole. It has a diameter of 3cm.

What is the surface area of the toilet paper roll. Remember to account for the hole.



2) A wheel of brie cheese is 10cm tall and 9cm long. What is the surface area of the full wheel of cheese?



3) A pot has no lid on top. The pot is 14cm tall and has a radius of 10cm. What is the surface area of the pot?



Surface Area – 3D Composite Objects

Questions

Find the surface area of the 3D composite objects

1)

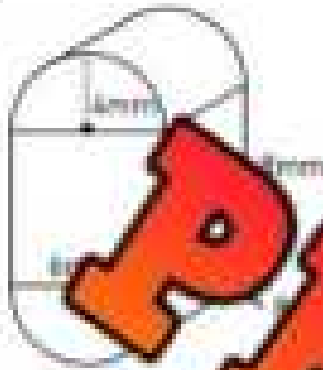

Surface Area: _____

2)

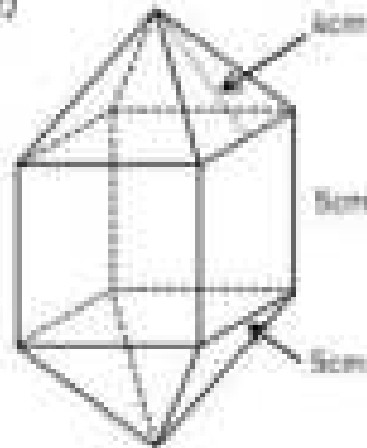

Surface Area: _____

3)

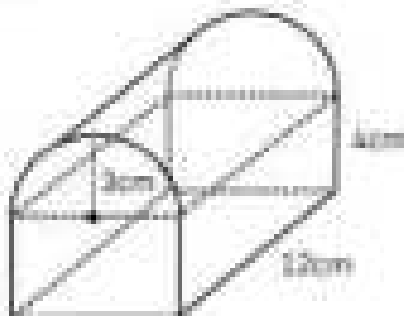

Surface Area: _____

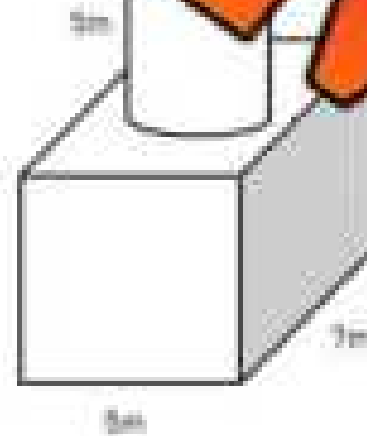

Surface Area: _____

Surface Area – 3D Composite Objects

Questions

Find the surface area of the 3D objects below. Note the holes!

1)

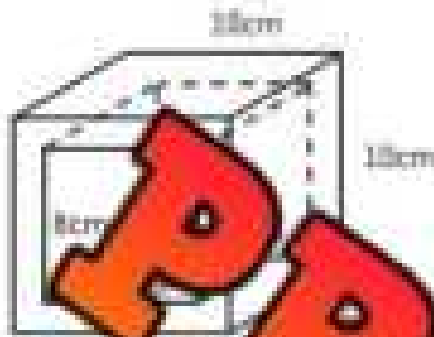

Surface Area: _____

2)



Surface Area: _____

3)

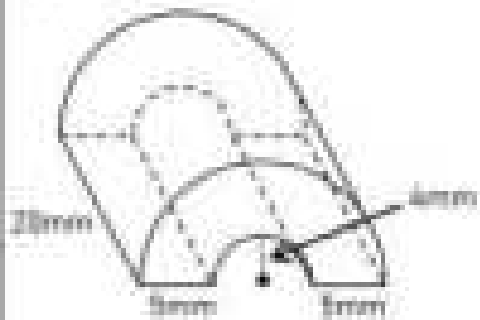

Surface Area: _____

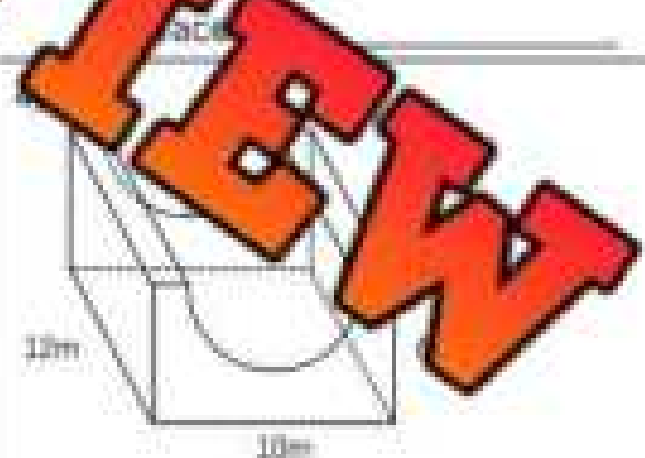

Surface Area: _____

PREVIEW

Surface Area – Word Problems

Questions

Answer the word problems below

1) A half-pipe skateboard ramp has been built with the dimensions below.

a) What is the surface area of the half-pipe?

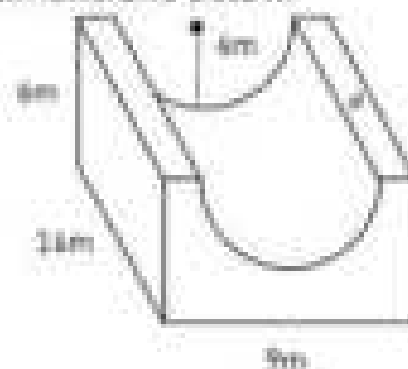

b) When a skateboarder jumps, how much room is there for them to land on the top of the ramp? What are the dimensions of the area that is labelled with an a ?

2) Courtney made a two-layer cake using a rectangular tin and a round tin. Instead of using icing between the two-layers, she used jam to hold them together. Courtney will cover the outside of the cake with vanilla icing (the bottom).

a) What is the area that will be covered by jam (two surfaces)?

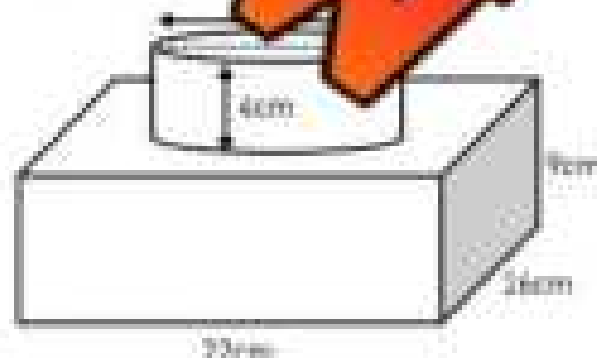

b) What is the area that will be covered in vanilla icing?

Volume - Cylinders

Questions

Solve the questions below

1)



Area of the Base: _____ Volume: _____

2)

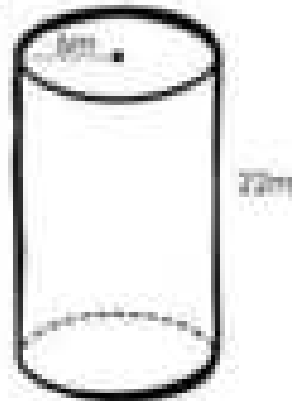

Area of the Base: _____ Volume: _____

3)

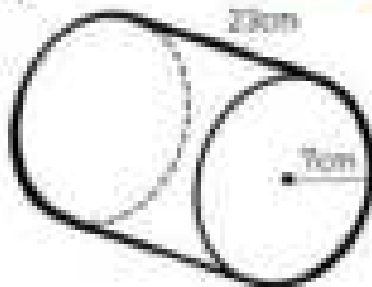

Area of the Base: _____ Volume: _____

4)



Area of the Base: _____ Volume: _____

5)



Area of the Base: _____ Volume: _____

6)

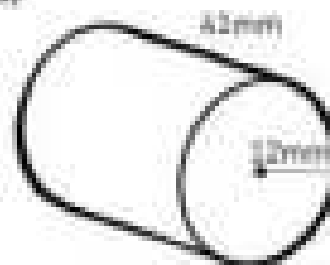

Area of the Base: _____ Volume: _____

Volume of Cylinders



Part 1

Fill in the blanks to investigate the area of the base and the volume

	Radius	Area of Base	Height	Volume
1)	9 mm		13 mm	
2)	_____ mm		15 mm	
3)			10 cm	
4)			6 km	
5)	9		8 cm	
6)	13 cm		11 cm	
7)	6 m		12 m	
8)	9 m		_____ m	

Part 2

Answer the questions below

1)	<p>The radius of a swimming pool is 4.1 metres. The depth of the pool is 1.3 metres. What is the volume of the swimming pool?</p>	
2)	<p>A can's base has an area of 37 cm^2. The volume of the can is 407 cm^3. What is the height of the can?</p>	
3)	<p>A bucket has a height of 9cm. The bucket's base has an area of 22 cm^2.</p> <p>a) What is the volume of the bucket?</p> <p>b) If 1 cm^3 of volume has the capacity to hold 1mL of water, how many mL can the bucket hold?</p>	

Exit Cards

Cut Out

Cut out the exit cards below and have students complete them at the end of class.

Name: _____

1) Fill in the blanks to investigate the area of the base, height, and the volume.

	Radius	Area of Base	Height	Volume
1)	10cm		10cm	
2)	10cm		15cm	
3)	10cm		20cm	392.5cm ³
4)	7cm	154cm ²		924cm ³

2) A cylindrical water tank has a base area of 200 cm² and a height of 2 meters.

- What is the volume of the tank in cubic centimeters (cm³)?
- If 1 liter of water is equal to 1,000 cm³, how many liters of water can the tank hold?

Name: _____

1) Fill in the blanks to investigate the area of the base, height, and the volume.

	Radius	Area of Base	Height	Volume
1)	8cm		10cm	
2)	4cm		15cm	
3)	2.5cm		20cm	392.5cm ³
4)	7cm	154cm ²		924cm ³

2) A cylindrical water tank has a base area of 200 cm² and a height of 2 meters.

- What is the volume of the water tank in cubic centimeters (cm³)?
- If 1 liter of water is equal to 1,000 cm³, how many liters of water can the tank hold?

Volume of Cylinders

Instruction

Answer the questions below

1) There are two types of hay bales – one that is in the shape of a cylinder and one that is in the shape of a rectangular prism. The cylinder-shaped hay bale is 300cm tall and 150cm long. The rectangular-shaped hay bale has the following dimensions: 1.5m by 1.0m by 2.0m.

a) Which type of hay bale contains more hay?



b) Joel thinks that the cylinder-shaped hay bale out of 3 rectangular-shaped hay bales. Is he right? Explain.



2) You are planning to make candles to sell. What would your candles be?

a) Draw a picture of one of the candles and label the dimensions.

b) What is the volume of the candle?

c) For every 10cm^3 , it costs you 30 cents. How much would the candle cost you in total?

Activity: "Cylinder Volume Toss Challenge"

Objective

What are we learning about?

Students will reinforce their understanding of finding the volume of cylinders through a fun, team-based activity that involves answering volume problems and shooting a paper ball into a bin.

Materials

What you will need for the activity.

- Index cards
- Recording sheet for each team
- Paper balls (one per student)
- Bins or baskets (one per team)
- Desks (one per team)



Instructions

How you will play the activity.

1. Arrange the classroom so that there is enough room for multiple teams to work simultaneously. Place a desk about 10 feet away from a bin or basket.
2. Place a stack of index cards with area problems on each desk.
3. Provide each team with a recording sheet and a paper ball.
4. Divide the students into teams of about five members.
5. Each team stands in a line behind their respective desk.
6. The first student in line flips over an index card and solves the problem related to the volume of a cylinder on the recording sheet.
7. Once the answer is recorded, the student attempts to shoot the paper ball into the bin.
8. If the student makes the shot, they place a tally mark on the team's tally sheet for a point. If they miss, no tally is given.
9. The student then goes to the end of the line, and the next student steps up to the desk to repeat the process.
10. The activity continues until all index cards have been solved.
11. Once all index cards are completed, the teacher collects the recording sheets and reviews the answers with the class.
12. For each incorrect answer, the team loses one point.
13. The team with the highest number of points after deductions is declared the winner.

Index Cards

Cut out the cards below

A water tank has a radius of 2 m and a height of 4 m. What is the volume of the tank?

A cylindrical candle has a radius of 3 cm and a height of 8 cm. What is the volume of the candle?

A cylindrical water bottle has a radius of 6 cm and a height of 12 cm. Find its volume.

A cylindrical barrel has a diameter of 2 m and a height of 5 m. Find the volume of the barrel.

A can of paint has a diameter of 10 cm and a height of 20 cm. Calculate the volume of the can.

A gas tank has a volume of 5000 cm^3 and a radius of 5 cm. What is its height?

The volume of a cylinder is 1000 cm^3 and the height is 10 cm. Find the radius of the base.

A cylindrical container has a radius of 7 cm and a height of 15 cm. What is its volume?

Index Cards

Cut out the cards below

A cylindrical pipe has a radius of 4 cm and a height of 10 cm. What is the volume of the pipe?

A cylindrical water tank has a radius of 3 m and a height of 8 m. What is the volume of the tank?

A large silo has a diameter of 10 m and a height of 20 m. Find the volume of the silo.

A container has a base area of 100 cm^2 and a height of 25 cm. Find the volume of the container.

A cylindrical vase has a radius of 6 cm and a height of 15 cm. What is the volume of the vase?

A soda can has a radius of 4.7 cm and a height of 12 cm. Find the volume of the can.

The volume of a cylindrical drum is 2000 cm^3 and the radius is 5 cm. Find the height of the drum.

A cylinder has a volume of 1200 cm^3 and a height of 10 cm. What is the radius of its base?

PREVIEW

Cylinder Volume Toss Challenge

Answers

Record your answers below

Question	Answer
1	
2	
3	
4	
5	
6	
7	
8	
9	
10	
11	
12	

Question	Answer
13	
14	
15	
16	
17	
18	
19	
20	
21	
22	
23	
24	

PREVIEW

Tally Chart

Record your makes in the tally chart below

Tallies - Made Shots	Total

Wrong Answers	Final Score

Volume – 3D Composite Objects

Questions

Find the volume of the 3D objects

1)

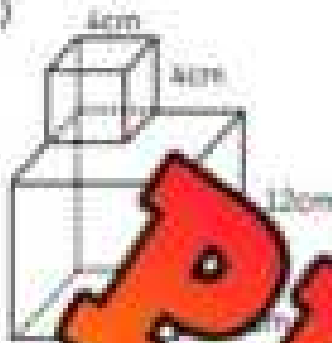

Volume: _____

2)

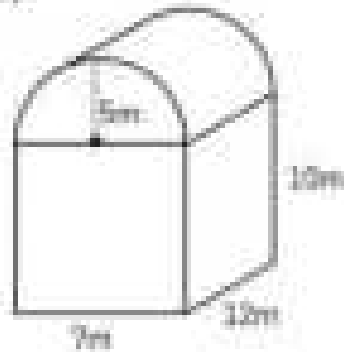

Volume: _____

3)

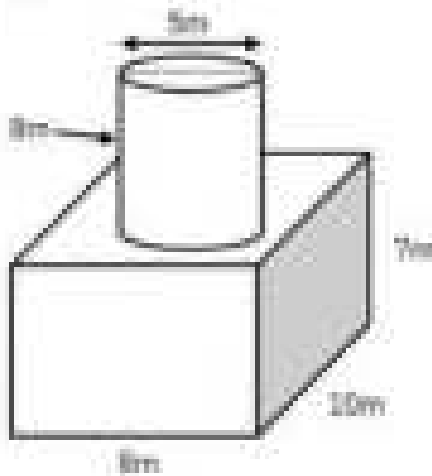

Volume: _____

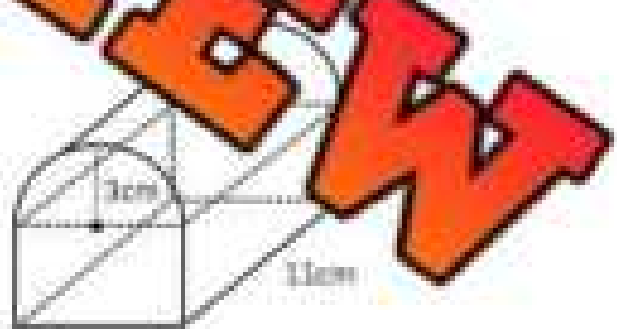

Volume: _____

Volume – 3D Composite Objects

Questions

Find the volume of the 3D objects that have holes in them

1)

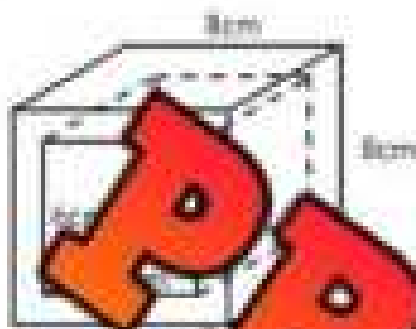

Volume: _____

2)



Volume: _____

3)

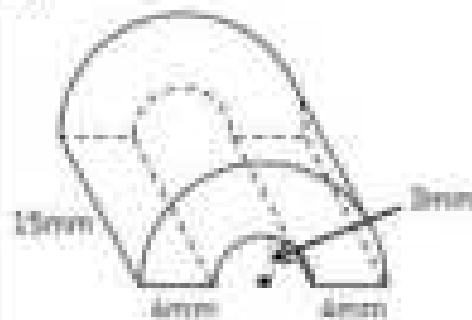

Volume: _____

4)

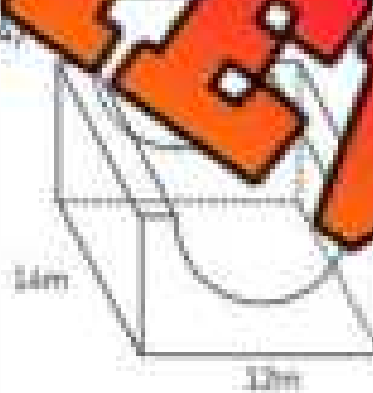

Volume: _____

Unit Test – Surface Area and Volume

Part 1

Find the area and perimeter of each composite shape

1)



Perimeter: _____

Area: _____

2)

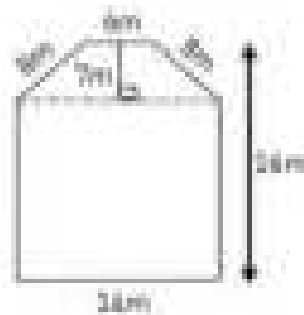

Perimeter: _____

Area: _____

3)

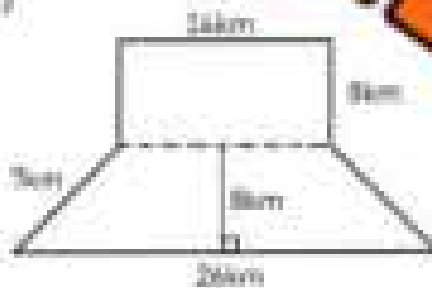

Perimeter: _____

Area: _____

4)



Perimeter: _____

Area: _____

Part 2

Fill in the blanks below

1)

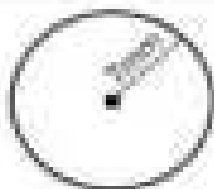

Radius = _____

Diameter = _____

Circumference = _____

Area = _____

2)

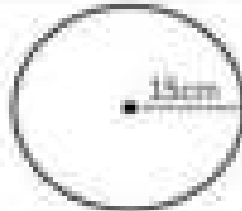

Radius = _____

Diameter = _____

Circumference = _____

Area = _____

3)

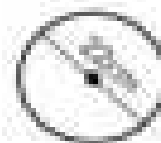

Radius = _____

Diameter = _____

Circumference = _____

Area = _____

Part 6

Find the volume and surface area of the 3D objects below



Volume: _____

Surface Area: _____

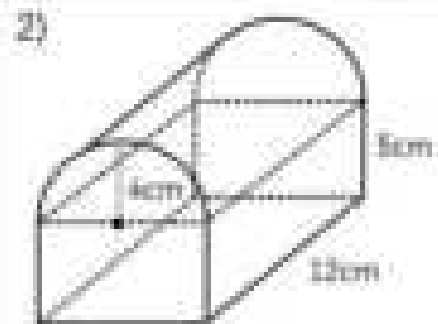

Volume: _____

Surface Area: _____

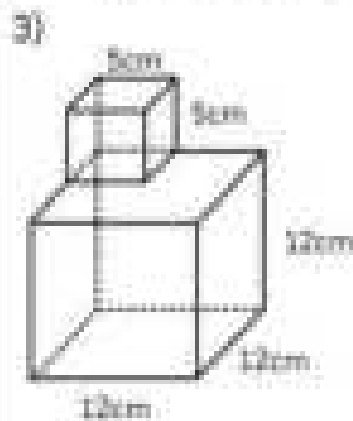

Volume: _____

Surface Area: _____



Volume: _____

Surface Area: _____

Part 7

Answer the word problems below

1) Josh is building a wooden birdhouse. The dimensions of the birdhouse have been displayed on his diagram below.

What is the surface area of the birdhouse with the hole?

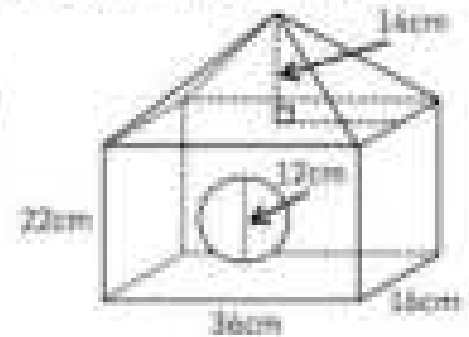

2) A half-pipe skateboard ramp is built with the dimensions below.

a) What is the surface area of the half-pipe?



b) How much space does the half-pipe occupy?

Intro – Pythagorean Theorem

The properties of a right triangle can be used to find an unknown side length. The longest side of a right triangle is always opposite the 90° angle and is called the **hypotenuse**.

The formula for calculating the length of the hypotenuse is: $a^2 + b^2 = c^2$

- If side a is 3 units long, then a square on this side has an area of 3^2 or 9.
- If side b is 4 units long, then a square on this side has an area of 4^2 or 16.
- If the hypotenuse c is equal to the combined areas of the squares on sides a and b, then the square on side c must have an area of $9 + 16$. This means the length of side c must be $\sqrt{25}$.

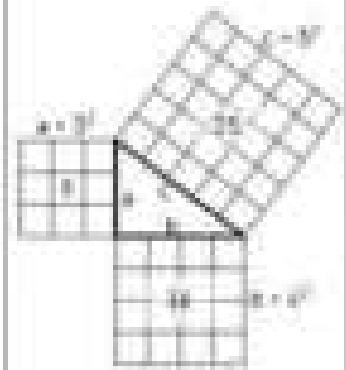

PREVIEW

Part 1

Label the sides of the right triangles: a, b, and c

1)

2)

4)

Part 2

Evaluate

	Question	Answer
1)	3^2	
2)	8^2	
3)	10^2	
4)	$\sqrt{36}$	

	Question	Answer
5)	$\sqrt{144}$	
6)	$\sqrt{16}$	
7)	7^2	
8)	$\sqrt{11}$	

Part 3

Label the triangles: a, b, c and fill in the blanks to find their values

1)

$a^2 + b^2 = c^2$

_____ + _____ = _____

Hypotenuse = _____

2)

$a^2 + b^2 = c^2$

_____ + _____ = _____

Hypotenuse = _____

Pythagorean Theorem – Word Problems

**Instructions**

Answer the questions below

1)

In a right-angled triangle, the lengths of the two shorter sides are 3 cm and 4 cm. What is the length of the hypotenuse?

2)

A right-angled triangle has one leg that measures 8 meters and another leg that measures 15 meters. What is the length of the hypotenuse?

3)

A building is 30 meters tall, and a ladder is leaning against the top of the building. If the base of the ladder is 25 meters away from the building, how long is the ladder?

4)

A rectangular billboard is 15 meters tall and 20 meters wide. A pole runs from the bottom corner to the top corner. How long is the pole?

5)

A rectangular garden is 12 meters long and 8 meters wide. If a diagonal path is drawn across the garden, what is the length of the path?

PREVIEW

Pythagorean Theorem – Missing Side**Instructions**

Find the value of the hypotenuse. Round the answer to the nearest tenth.

1)



2)

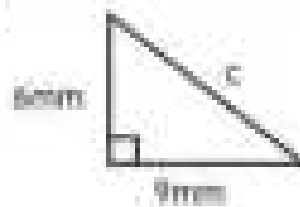

3)

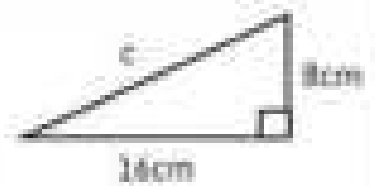

4)

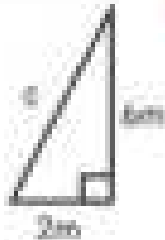

5)

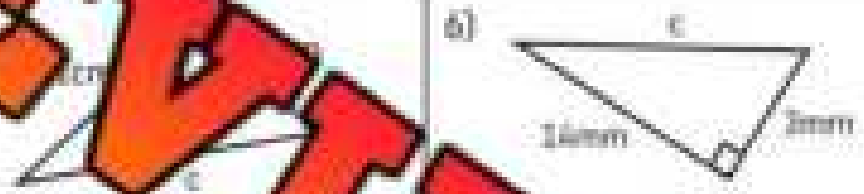

7)



8)

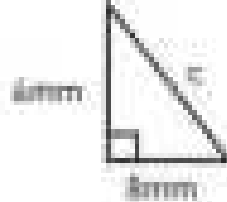

9)



Exit Cards

Cut Out Cut out the exit cards below and have students complete them at the end of class

Name: _____

1) Find the value of the missing side.



2) A rectangular park measures 45m by 60m. A diagonal path cuts across the park. Find the length of the path to the nearest tenth.

Name: _____

1) Find the value of the missing side.

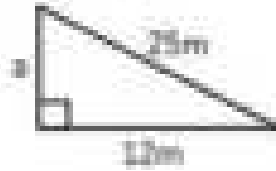

2) A rectangular park measures 45m by 60m. A diagonal path cuts across the park. Find the length of the path to the nearest tenth.

Name: _____

1) Find the value of the missing side.



2) A rectangular park measures 45m by 60m. A diagonal path cuts across the park. Find the length of the path to the nearest tenth.

Name: _____

1) Find the value of the missing side.



2) A rectangular park measures 45m by 60m. A diagonal path cuts across the park. Find the length of the path to the nearest tenth.

PREVIEW

Pythagorean Theorem – Word Problems

Instructions

Answer the word problems below

- 1) Find the hypotenuse of a right triangle with a base of 10cm and a height of 6cm.

- 2) Lily walked 4 km south and 3 km east. Calculate how far Lily is away from her house.



- 3) Julian built a triangular garden with the dimensions below. If he wanted to put a fence around his garden, how long would the fence need to be?



- 4) Ivy's house is a rectangular shape that is 15m wide by 9m high. How long is the diagonal of her house (from corner to corner)?

- 5) An envelope has the dimensions below. What is the height of the envelope?



Pythagorean Theorem – Missing Side

Instructions

Find the value of the missing side. Record your answer as a square root.



$$12^2 + 18^2 = c^2$$

$$144 + 324 = c^2$$

$$468 = c^2$$

$$c = \sqrt{468}$$

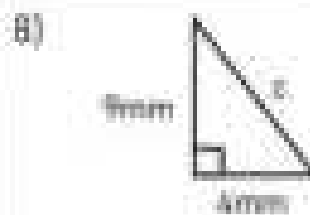
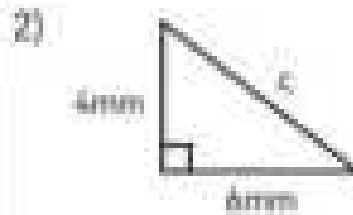

Math Tic-Tac-Toe: Pythagorean Challenge

Objective

What are we learning about?

Students will practice using the Pythagorean Theorem to find the missing side of right triangles in a fun, competitive game of tic-tac-toe. This activity will reinforce their problem-solving skills and teamwork.

O	O	X
	X	O
X	O	

Materials

What you will need for the activity:

- Whiteboard or paper
- Markers or colored markers
- Pre-written Pythagorean Theorem problems for each cell of the tic-tac-toe grid

Instructions

How you will play the game:

- 1) Preparation:** Hand out Tic-Tac-Toe worksheets to pairs of students. Each worksheet should have a large tic-tac-toe grid with a Pythagorean Theorem problem in each cell. One side of the right triangle is missing in each problem.
- 2) Instructions:**
 - Students will play individually against each other, one as "X" and the other "O."
 - The student playing "X" will go first. They will choose a cell, solve the Pythagorean Theorem problem in that cell, and check their answer with their partner. If the solution is correct, they place an X in that cell.
 - If the answer is incorrect, they do not place their mark, and it becomes the "O" player's turn. The "O" player will then choose a cell, solve the problem, and check their answer. If correct, they place an O in that cell.
 - The game continues with alternating turns.
- 3) Winning the Game:** The first player to get three marks in a row (horizontally, vertically, or diagonally) wins the game.
- 4) Discussion:** After the game, students should discuss with their partner the different strategies they used to solve the problems and any challenges they faced during the activity.

Tic-Tac-Toe

Use the following tic-tac-toe grids for the game.

Lily walked 5 km south and 12 km east. How far is she from her starting point?

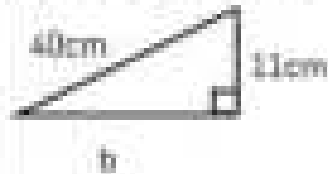

Jacob's rectangular garden measures 18 m by 24 m. Find the diagonal length.



Lucas paddled his kayak 4 km north and 3 km east. How far is he from his starting point?

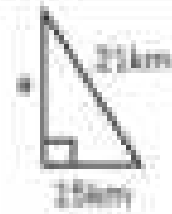

David climbs 12m up a tree and moves 5m to the right on a branch. What is his diagonal distance from the tree base?

A rectangular rug is 9 m wide and 12 m long. What is the diagonal length?



Ella's garden is a rectangle measuring 20m by 15m. Find the diagonal length.

The base of a TV screen measures 40cm, and the height is 30cm. Find the diagonal size of the screen.



Find the hypotenuse of right triangle with legs of 13cm and 14cm.

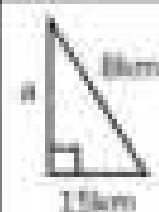

Tic-Tac-Toe

Use the following tic-tac-toe grids for the game.

Chris's living room measures 5 m by 12 m. Find the diagonal length.

Lisa climbs 3 m up a ladder and moves 4 m sideways on a scaffold. What is her diagonal distance from the ground?

A triangle has legs of 5 cm and 12 cm. What is the hypotenuse?

A rectangular field is 12 m wide and 35 m long. What is the diagonal length?

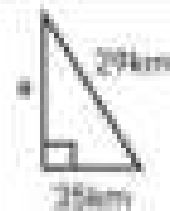

Ave jogged 7 km west and 24 km south. How far is she from her starting point?



Nathan walked 3 km north and 4 km east. Calculate the distance from his starting point.

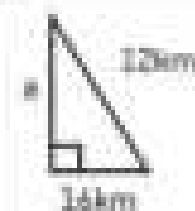

Hannah hiked 15 km east and 20 km south. How far is she from the starting point?



Mia flew her drone 8 m upward and 15 m to the right. Calculate the diagonal distance.

Jamie's rectangular swimming pool measures 20 m by 25 m. Find the diagonal length.

Pythagorean Theorem – Word Problems

Instruction

Answer the word problems below

- 1) Robert has a 4m ladder that he is using to get as high as possible to hang his Christmas lights. He puts the ladder 2 metres away from the wall.

- a) Label the dimensions on the diagram
 b) How high is the top of the ladder off the ground?



- 2) Howard has a huge house with a very tall bookshelf. He needs to climb 9m to find the book he wants. How far away from the top of the ladder to be at the height of the book he wants? How far should he put the ladder away from the bookshelf?

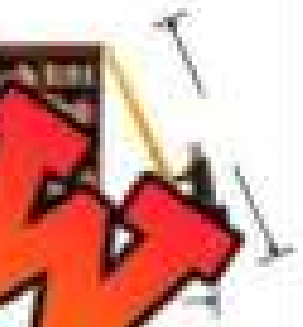

- 3) A pirate is on a treasure hunting mission. His GPS tells him he is 32km away from the treasure. He decides to travel 21km due east. The GPS now tells him that the treasure is due south from where his boat is. How far south does he need to travel to find the treasure?

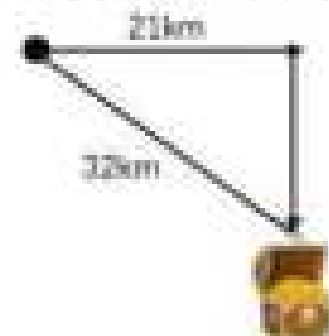

Pythagorean Theorem – Missing Side**Instruction**Find the value of x .

Round the answer to the nearest tenth or leave as a square root.

1) 11cm

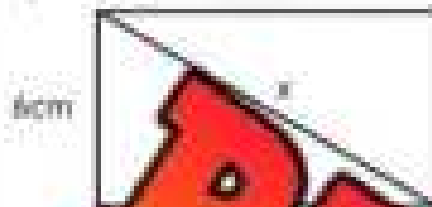

2)

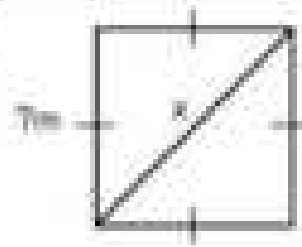

3)

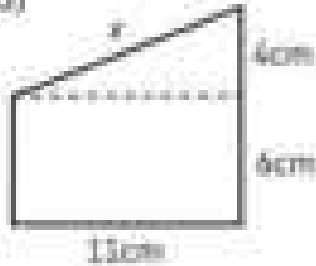

6)

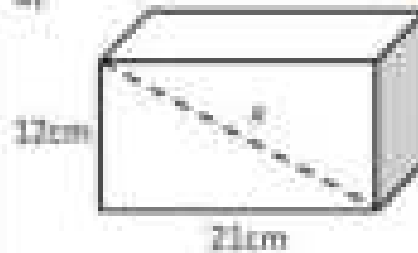

5)



Pythagorean Theorem – Word Problems

Instruction

Answer the word problems below

- 1) TVs are measured diagonally from corner to corner. Jeffrey wants a 150cm TV. He likes the look of one that has a base of 140cm and a height of 54cm. Is the TV 150cm diagonally?



- 2) To get from point A to point B, you need to walk around the pond. To avoid the pond, you walk 8m and 4m. To the nearest metre, how many metres would you have saved if you could walk through the pond?



- 3) A baseball diamond is a square with sides of 30m. How far is the distance between first base and third base?

- 4) The local fire department has been called to a burning building. They need their ladder to reach the 4th floor, which is 22m high. They know that the ladder will need to be at least 12m away from the building. If they brought a 25m ladder, will they reach the fourth floor?

Exit Cards

Cut Out Cut out the exit cards below and have students complete them at the end of class.

Name: _____

Real-life Pythagorean theorem problems. Find the value of the missing side.

1) A tree is 20 m tall and casts a shadow 15 m long on the ground. What is the distance from the top of the tree to the end of the shadow?

2) A ramp is used to load equipment onto a truck. The ramp is 2 m high and 4 m long along the ground. What is the length of the ramp itself?

PREVIEW

Name: _____

Real-life Pythagorean theorem problems. Find the value of the missing side.

1) A tree is 20 m tall and casts a shadow 15 m long on the ground. What is the distance from the top of the tree to the end of the shadow?

2) A ramp is used to load equipment onto a truck. The ramp is 2 m high and 4 m long along the ground. What is the length of the ramp itself?

Identify Right Triangles – Pythagorean Theorem

We can use the Pythagorean Theorem to find out if a triangle is a right triangle or not. If we have all the measurements of the triangle, we can plug them into the equation. If the equation is true, the triangle is a right triangle and if it is false, it is not.

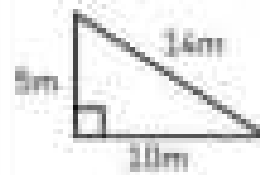

Solution

$$a^2 + b^2 = c^2$$

$$9^2 + 10^2 = 14^2$$

$$81 + 100 = 196$$

$$181 \neq 196$$

This equation is false, therefore this is not a right triangle.

Questions Is the triangle a right triangle?



Yes No



No

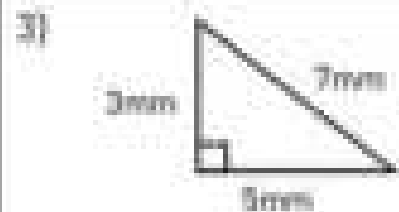

Yes No

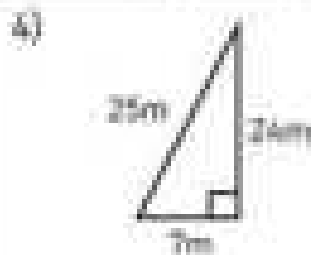

Yes No



Yes No



Yes No



Yes No



Yes No



Yes No

Pythagorean Theorem – Word Problems

Directions

Draw and label the triangles and decide if the triangles are right or not.

- 1) In the triangle ABC, the sides AB, BC, and AC measure 7cm, 24cm, and 25cm respectively. Is the triangle a right triangle?

- 2) In the triangle JKL, the sides JK, KL, and JL measure 5cm, 12cm, and 14cm respectively. Is the triangle a right triangle?

- 3) In the triangle PQR, the sides PQ, QR, and PR measure 29mm, 41mm, and 61mm respectively. Is the triangle a right triangle?

- 4) In the triangle XYZ, the sides XY, YZ, and XZ measure 20cm, 20cm, and 29cm respectively. Is the triangle a right triangle?

PREVIEW

Pythagorean Theorem – Quiz

Part 1 Label the sides of the right triangles: a, b, and c.

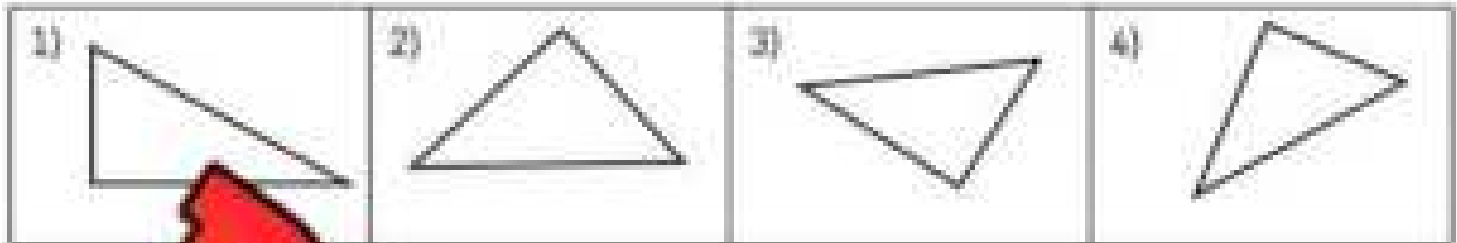

Part 2 Find the missing side.

#	Question	Answer	#	Question	Answer
1)	7^2		4)	$\sqrt{121}$	
2)	9^2		5)	$\sqrt{64}$	
3)	$\sqrt{16}$			6^2	

Part 3 Find the value of the missing side.

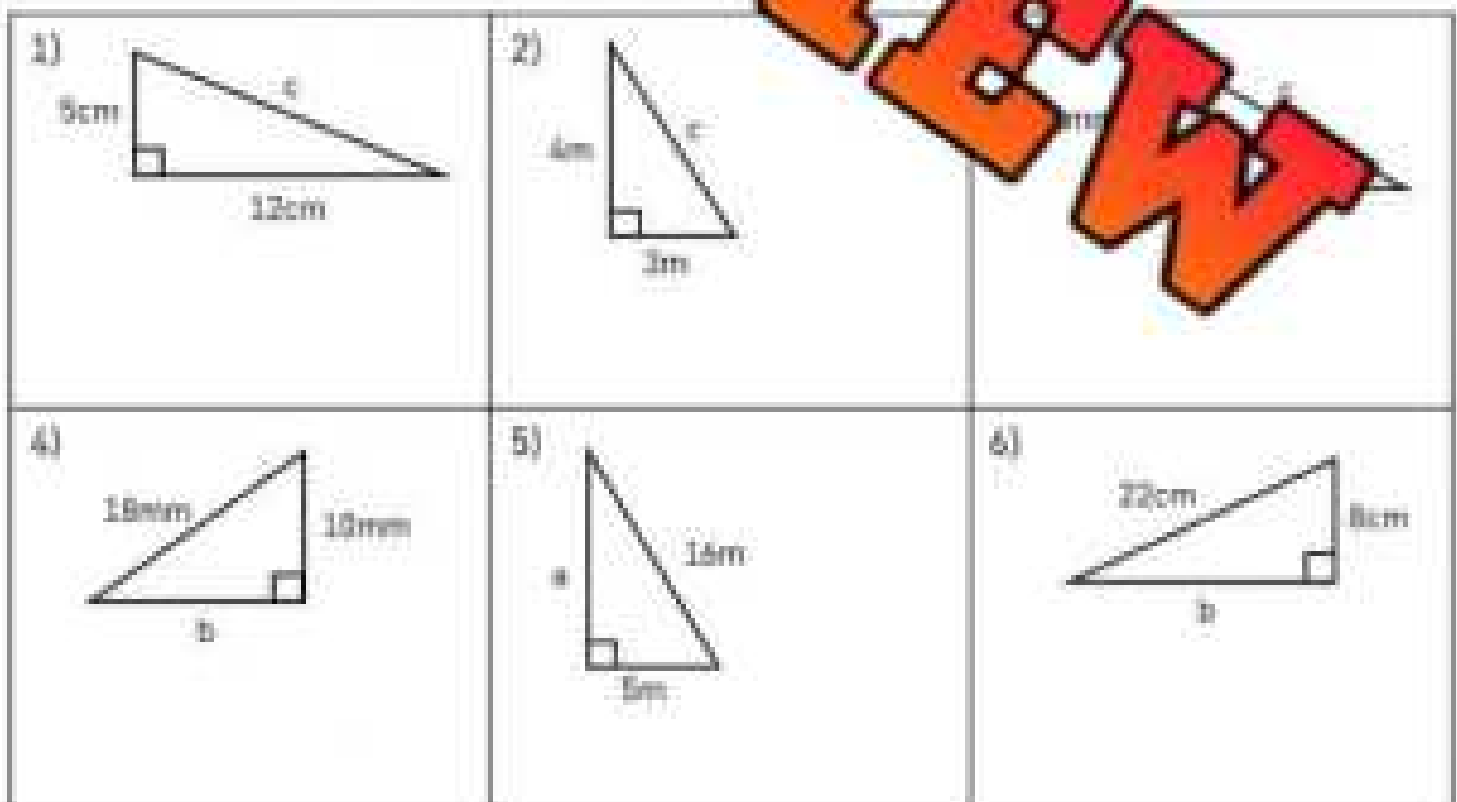

Part 4

Find the value of x .

Round the answer to the nearest tenth or leave as a square root.

1)



2)

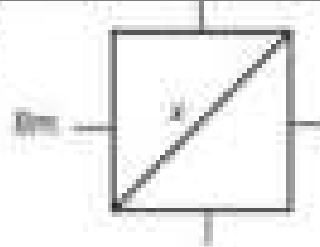

Part 5

Is the triangle a right triangle?

1)

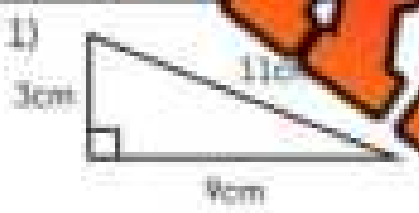

Yes

No

3)

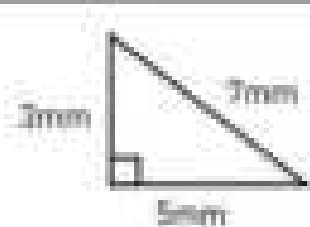

Yes

No

No

Part 6

Is the triangle a right triangle?

- 1) A 14m ladder is leaning against a house. The bottom of the ladder is 7m from the house. How high does the ladder reach to the nearest tenth?
- 2) A building casts a shadow of 10m on the ground. The length from the top of the building to the end of the shadow is 26m. How tall is the building?



Workbook Preview



Grade 8

F1. Money and Finances

	Curriculum Expectations	Pages That Cover the Expectations
F1.1	describe some advantages and disadvantages of various methods of payment that can be used when dealing with multiple currencies and exchange rates	5 - 24
F1.2	create a financial plan to reach a long-term	
F1.3		
<p>Preview of 65 pages from this product that contains 122 pages total.</p>		
F1.4	determine the growth of simple and compound interest at various rates using digital tools, and explain the impact interest has on long-term financial planning	45 - 60
F1.5	compare various ways for consumers to get more value for their money when spending, including taking advantage of sales and customer loyalty and incentive programs, and determine the best choice for different scenarios	61 - 66
F1.6	compare interest rates, annual fees, and rewards and other incentives offered by various credit card companies and consumer contracts to determine the best value and the best choice for different scenarios	67 - 74

Exchange Rates - Intro

There are 180 different currencies that are recognized in the world. Every currency is valued differently. This means that a lot of money in one currency could be worth very little in another. For example, if you took one dollar in Canadian money to Japan, it would be worth 90 Japanese Yen.

Exchange rates keep track of how much money is worth. A rate compares two or more currencies together. Therefore, the exchange rate between a Canadian Dollar and Japanese Yen is 1 CAD to 90 JPY.

Part 1: Answer the questions below



1) Why do you think we need exchange rates?

2) How much do you think a candy bar would cost in Japan? Explain your answer.

Part 2: Convert money between CAD and Yen using multiplication and division

	Canadian Dollar	Japanese Yen
1)	\$1	
2)	\$2	
3)	\$10	
4)	\$50	
5)	\$200	
6)	\$10,000	

	Japanese Yen	Canadian Dollar
1)	¥720	
2)	¥990	
3)	¥3600	
4)	¥5400	
5)	¥9000	
6)	¥900,000	

World Currency Exchange Rankings

Out of the 180 currencies worldwide, each one has their own value. This means that 1 dollar is worth a lot more and a lot less in different currencies. The list below is of the top 10 currencies worldwide.

One value of each currency can be exchanged for the money shown in CAD.

This means for every Kuwaiti Dinar, you could exchange it for \$4.14 Canadian Dollars. If you had 1 US Dollar, you could exchange it for \$1.25 Canadian Dollars.

The value of a country's currency changes all the time. In fact, it can change by the second. This is because of a country's economic strength. If the value of their currency is high, it means that people in a country earn a lot of money. A country will have a stronger economy and therefore, a higher value.

Rank	Currency	CAD Rate
1)	Kuwaiti Dinar	\$4.14
2)	Bahraini Dinar	\$3.31
3)	Omani Rial	\$3.24
4)	Jordanian Dinar	\$1.76
5)	British Pound Sterling	\$1.70
6)	Cayman Islands Dollar	\$1.50
7)	European Euro	\$1.44
8)	Swiss Franc	\$1.34
	US Dollar	\$1.25
	Canadian Dollar	\$1.00

Part 1 Answer the question below.

If you could have 100 of any of these currencies, which one would you choose? Explain your choice.

Part 2 Convert money from other currencies to Canadian Dollars (CAD)

	Money	Other Currency	CAD
1)	\$3	Swiss Franc	
2)	\$5	US Dollar	
3)	\$7	Cayman	
4)	\$10	Euro	
5)	\$20	Kuwaiti Dinar	

	Money	Other Currency	CAD
6)	\$2	British Pound	
7)	\$6	Bahraini Dinar	
8)	\$25	US Dollar	
9)	\$150	Omani Rial	
10)	\$500	Jordanian Dinar	

Name: _____

Converting Currencies

The table displays the top 5 used currencies around the world. The Canadian Dollar is number 6. If you converted one Canadian Dollar into the other currencies, you would get the money shown in the table.

For example, 1 CAD will be exchanged for \$0.80 USD (US Dollars).

Rank	Currency (\$1 CAD To)	\$
1)	US Dollar	\$0.80
2)	Euro	€0.70
3)	Japanese Yen	¥90.00
4)	Pound Sterling	£0.60
5)	Australian Dollar	\$1.10

Part 1 Convert 1 CAD to other currencies.

	CAD	Other Currency	\$
1)	\$10	US Dollar	
2)	\$75	Euro	
3)	\$120	Japanese Yen	
4)	\$1000	Pound Sterling	
5)	\$5000	Australian Dollar	

	CAD	Other Currency	\$
6)	\$5.50	US Dollar	
7)	\$32.75	Euro	
8)	\$41.82	Japanese Yen	
9)	\$20.00	Pound Sterling	
10)	\$43.50	Australian Dollar	

Part 2 Answer the questions below.

1) Ella spent \$24.50 CAD on a t-shirt in Berlin, Germany. How much was the t-shirt in Euros?



2) Levi is going on vacation to Glasgow, Scotland. He converted \$2000 CAD to Pounds Sterling. How much should he get in return?

3) Sofia bought a boomerang from Australia online. She paid \$48.25 CAD. How much was the boomerang in Australian Dollars?



4) Elena bought a kimono from an online store based out of Japan. She paid \$136.32 CAD. How much was the kimono listed for in Yen on the Japanese website?

Exit Cards

Cut Out

Cut out the exit cards below and have students complete them at the end of class.

Name: _____

a) Convert the CAD to other currencies.

CAD	Other Currency	\$
\$2234	Japanese Yen	
\$99.90	Euro	
\$6840.98	Australian Dollar	
\$2150	Pound Sterling	

b) Olivia buys a souvenir in France that costs €280 (Euros). She wants to know how much she paid in Canadian Dollars. How much did the item cost in CAD?

Name: _____

a) Convert the CAD to other currencies.

CAD	Other Currency	\$
\$2234	Japanese Yen	
\$99.90	Euro	
\$6840.98	Australian Dollar	
\$2150	Pound Sterling	

b) Olivia buys a souvenir in France that costs €280 (Euros). She wants to know how much she paid in Canadian Dollars. How much did the item cost in CAD?

Name: _____

a) Convert the CAD to other currencies.

CAD	Other Currency	\$
\$2234	Japanese Yen	
\$99.90	Euro	
\$6840.98	Australian Dollar	
\$2150	Pound Sterling	

b) Olivia buys a souvenir in France that costs €280 (Euros). She wants to know how much she paid in Canadian Dollars. How much did the item cost in CAD?

Name: _____

a) Convert the CAD to other currencies.

CAD	Other Currency	\$
\$2234	Japanese Yen	
\$99.90	Euro	
\$6840.98	Australian Dollar	
\$2150	Pound Sterling	

b) Olivia buys a souvenir in France that costs €280 (Euros). She wants to know how much she paid in Canadian Dollars. How much did the item cost in CAD?

Name: _____

Exchange Rate
1:1

Exchange Rate – Souvenir Shop

Menu	\$USD
T-shirt	\$22.50
Sweater	\$45.75
Hat	\$15.00
Postcard	\$2.75
Keychain	\$5.50

A souvenir shop in Buffalo, New York sells many items to Canadian tourists. They list their price in USD but will accept Canadian money at a rate of 1USD to 1.35CAD. They know the exchange rate is high, but they want to make sure they can exchange the CAD to USD at the bank and not lose money.

Question: How much will the Canadian customers pay in CAD?

1) Aurora buys a T-shirt and a keychain. How much does she owe in CAD?



2) Luke buys a sweater and keychain. How much does he owe in CAD?

3) Hudson has \$35 CAD left after his trip to the USA. He wants to buy a T-shirt, and postcard.

a) Can he afford it?

b) If yes, how much money will he have left?

4) Penelope wants to buy one of each item. How much will it cost her in CAD?



5) Wyatt has \$23 in USD and \$30 in CAD. Can he buy a sweater?

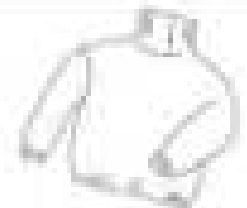

Exchange Rate – Burger Shop

Jayden works at a burger shop in Niagara Falls, Ontario. He serves many customers from the United States, who cross the border to check out Canada's side of the falls.

He provides his customers with an exchange rate of 1CAD to 0.85USD. Some of his US customers don't agree with the rate, but he must make sure he doesn't lose money in the exchange.

Menu	\$CAD
Burger	\$5.50 each
Fries	\$3.50 each
Drink	\$2.50
Onion Rings	\$3.75
Combo – Burger and Fries	\$7.50

Questions 1-5 are based on the information above.

1) A customer orders 1 burger and 1 onion rings. How much will Jayden charge them in USD?

2) A customer orders 2 combos. How much will they owe in USD?

3) A customer orders onion rings, fries, and a drink. They give Jayden a \$10 USD bill. How much change will Jayden give them in USD?



4) Jayden has run out of USD. He uses a rate of 1USD equal to 1.17CAD to give change back in CAD. A customer pays \$20USD to Jayden for 3 burgers. How much change does Jayden owe them in CAD?



5) Jayden earned \$323USD today selling to tourist from the United States. He brings it to the bank and exchanges it to CAD with an exchange rate of 1CAD to 1.27USD.

a) How much CAD did he get?

b) How much extra money did he earn by using an exchange rate of 1CAD to 1.15USD in his store?



Comparing Money – Different Currencies

Rank	Currency	1	CAD
1)	US Dollar (USD)	1USD	\$1.25
2)	Euro (EUR)	1EUR	\$1.45
3)	Japanese Yen (JPY)	1JPY	\$0.011
4)	Pound Sterling (GBP)	1GBP	\$1.70
5)	Australian Dollar (AUD)	1AUD	\$0.92

The top 5 currencies in the world are displayed in the table. Their values are presented as a rate of 1 of their currency to CAD.

Example – if we convert 1JPY, we will get \$0.01 or 1 cent. We will get \$0.92CAD for 1AUD.

Part 1: Rank the currencies to compare the currency amounts.

1)	\$20.00USD	€12.00EUR	6)	\$215.00CAD	\$250.00AUD
2)	\$75.00USD	€100.00EUR	7)	\$382.10CAD	¥1200.00JPY
3)	\$8.25CAD	\$100.00CAD	8)	\$150.00CAD	€725.00EUR
4)	€22.50GBP	\$25.15CAD	9)	\$100.00USD	\$1100.00CAD
5)	\$125.00CAD	€92.00EUR	10)	\$177.00CAD	\$1352.21CAD

Part 2: Answer the questions below

- 1) Peter is shopping for a new guitar from 5 different countries around the world. The same guitar is priced in 5 different currencies. Rank the prices from lowest to highest.

\$605AUD, \$442USD, €326GBP, ¥21200JPY, €78EUR

1)	2)	3)	4)	5)
----	----	----	----	----

- 2) Steven is deciding where he can vacation for the cheapest cost. He found out the price of an average dinner cost for 5 different countries. Rank the countries from cheapest to most expensive.

Japan - ¥2415JPY, Australia - \$25.95AUD, England - €22.32GBP,
USA - \$27.53USD, Belgium - €21.38EUR

1)	2)	3)	4)	5)
----	----	----	----	----

Examples of Currency Exchanges

People are spending money in other countries more and more. With the use of the internet, we can access stores from countries around the world with a single click. When we buy goods or services in other countries, we use our Canadian money to buy things that are in other currencies.

Goods are things we can hold, while services are when people or businesses help us with something we need.

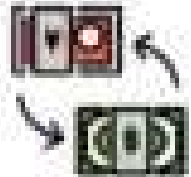

Goods Think of 3 goods you might buy from another country

	Goods (example - surfboard from California)
1)	
2)	
3)	

Services Think of 3 services you might buy from another country

	Services (example - A wedding in Ireland)
1)	
2)	
3)	

Scenarios Brainstorm 3 scenarios where you would require transferring money to another country

	Scenario (example - sending money to a friend in another country)
1)	
2)	
3)	

Researching Currencies Around the World

Research online 10 different currencies and compare them to our Canadian currency. You can use the keywords on Google: "currencies around the world" to find a list of all the currencies used around the world.



Tip: To find the value per 1CAD, type in, "CAD to (name of other currency)" on Google

Research

Fill in the table below with your research.

	Currency Ex. Canadian Dollar	Currency Code Ex. CAD, USD	Value Per 1CAD (CAD to ...)
1)			
2)			
3)			
4)			
5)			
6)			
7)			
8)			
9)			
10)			

PREVIEW

Transferring Money – Pros/Cons

Methods of Payment	Advantages (Pros)	Disadvantages (Cons)
Cash 	<ul style="list-style-type: none"> - Controls your spending because you can't spend money you don't have - No extra fees of using a card - You can get cash from other currencies before travelling so that you don't pay extra conversion fees 	<ul style="list-style-type: none"> - You can lose cash - If cash is stolen, it's gone for good - Transactions take longer - Can't pay for online purchases - Conversions are done manually and the business gets to decide which rate they will give you (could be unfair)
Credit Card 	<ul style="list-style-type: none"> - Can buy things you don't have and pay with now - Earn rewards that gives you to use for more in the future - Receive cash back on payments - You can use the credit all over the world 	<ul style="list-style-type: none"> - Easy to overspend with money you don't have which can lead to debt - You pay interest (average rate is 18%) - Credit card monthly fees - If you miss payments, you can damage your credit score - You will be charged up to 3% of your purchase if you buy something using a different currency
Debit Card 	<ul style="list-style-type: none"> - You can only spend money you have which leads to no debt - Less or zero fees - Can use for online purchases - Quick payments using tap feature - Allows access to interest-earning bank accounts - Can buy things all over the world because your bank will convert your money to other currencies 	<ul style="list-style-type: none"> - Can't earn rewards or points - Can't earn credit score - Risk of fraud on it - You will be charged 3% of your purchase if you buy something using a different currency
Electronic Money Transfer 	<ul style="list-style-type: none"> - Can pay for things without using debit or credit card - Can send money to anyone with an email address or phone number - You can only send money you have which saves you from debt 	<ul style="list-style-type: none"> - Can't access credit - Could send money to wrong address - There is a limit on how much you can send using an EMT - High fees for sending transfers - Cannot send an e-transfer from a Canadian bank to another country
Online Payments 	<ul style="list-style-type: none"> - Access your bank account to buy things online - Send money to other people and businesses in other countries - Can use different platforms like PayPal to access credit/debit cards 	<ul style="list-style-type: none"> - Will pay conversion fees of around 3% to buy things in other currencies using online payment platforms - Many online stores charge an extra 2% to convert your currency to their side currency

Explain

Which 2 advantages/disadvantages do you think are most important?

1) Credit Cards	Most Important Advantages/Disadvantages
Advantages	
Disadvantages	
2) Debit Card	Most Important Advantages/Disadvantages
Advantages	
Disadvantages	
3) Cash	Most Important Advantages/Disadvantages
Advantages	
Disadvantages	

PREVIEW

Payment in Other Currencies

Rank	Currency	1 Unit	CAD
1)	US Dollar (USD)	1 USD	\$1.25
2)	Euro (EUR)	1 EUR	\$1.45
3)	Japanese Yen (JPY)	1 JPY	\$0.011
4)	Pound Sterling (GBP)	1 GBP	\$1.70
5)	Australian Dollar (AUD)	1 AUD	\$0.92

Making payments in other currencies comes at a cost. For most payment methods, the average cost is 3%.

Example - If something costs €10 EUR, it will cost us $10 \times 1.45 = \$14.50$ CAD plus an addition 3% of the purchase price in CAD (14.50×0.03). This means we need to add \$0.44 to our total = \$14.94 CAD.

Calculate the total cost in CAD with a 3% conversion fee.

	Cost / Purchase Price	1 Unit Exchange Rate	3% Conversion Fee of P.P.	Total Cost
1)	\$20 USD		\$0.75	\$20.75
2)	\$60 USD			
3)	¥2000 JPY			
4)	€85 EUR			
5)	£175 GBP			
6)	\$252 AUD			
7)	\$750 USD			
8)	€29.42 EUR			
9)	¥22512 JPY			
10)	£5630.35 GBP			

Methods of Payment – Poster Assignment

Design a poster that a bank would use to promote the use of a method of payment.

Consider the following in your poster (Success Criteria):

- Highlight one important advantage of the payment method (include currency conversion)
- Use a slogan or one line to highlight this advantage
- Use a large title
- Use left text to keep the poster visually appealing
- Use graphics and pictures to help explain your message
- Fill the poster completely and do not waste space

Plan your poster using the organizer below to prepare for creating your poster.

1) Which method of payment will you use?

2) What will the title of your poster be?

3) What text will you include on your poster? 5

4) What pictures will you draw? Practice them below.

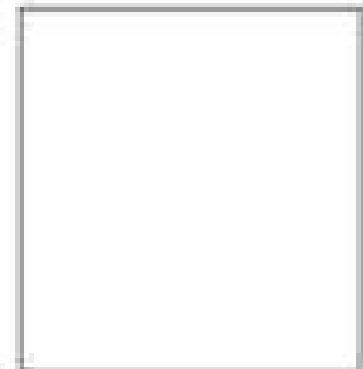
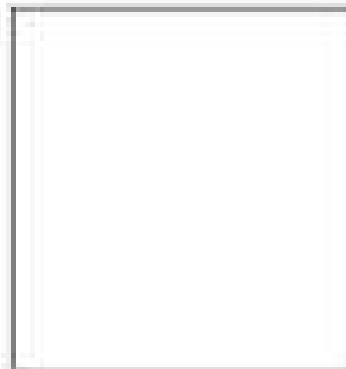
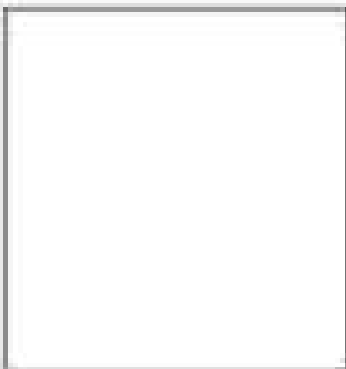

Sample Poster

Choose Debit



-No Interest!
-only a 2%
currency
conversion

Don't
use your
debit card
wherever
you need!



Name: _____

22

Accounting Exercise
1.1

Methods of Payment

PREVIEW

Social Media Post: Help Making a Financial Plan

@MoneyGoals101: 

Yo, how do you actually make a solid money plan so you can hit a big goal, like buying a car or starting a small biz, without going broke?

T:15 AM - 22/02/2025 - 3,403 SHARES - 7,126 LIKES

 **@CashQueen88:** Step one—figure out all your income sources. Hourly wage, salary, tips, commission, profits from a side hustle, even interest from your savings account. More streams = more money to your goal.

 **@FinanceNerd:** Don't get fooled by your gross income. Taxes, CPP, EI, and taxable benefits take a chunk out of what you keep! Always plan based on the take-home pay.

 **@FinanceNerd:** For investments, track both gains AND losses. Making \$500 in stocks in a year is great, but a \$100 loss elsewhere changes your actual earnings.

 **@CashQueen88:** Track your expenses: utilities, phone, food, Netflix, gas, even random stuff. Once you know where the money goes, you can cut what's not helping.

 **@BudgetBro:** Watch those discretionary spending habits. Concerts, and travel are cool, but they can slow down your savings. Look for free events sometimes.

 **@FinanceNerd:** Health + dental coverage is a game-changer. It's an expense, but not having it can lead to huge medical bills later, which can destroy your financial plan.

 **@CashQueen88:** Running a business? Think about bulk buying for supplies. More orders, buy in bulk to save money, or raise prices just enough to cover the cost of your customers.

 **@BudgetBro:** Bulk buying is a huge win for saving costs. Buying in larger quantities per unit means more profit, as long as you don't overstock stuff that won't sell.

 **@FinanceNerd:** Automate your savings so a set amount goes straight to your target savings account or investment. That's passive income while you sleep.

 **@CashQueen88:** Short-term goals (like \$500 in 2 months) keep you pumped, but don't forget the long-term ones (like \$5k in 2 years) so you don't blow all your savings halfway.

 **@BudgetBro:** If your income changes—like seasonal work or commission jobs—plan for those low months by saving extra during the high-income months.

 **@FinanceNerd:** Always compare your budget to your actual spending each month. If you keep going over in one category, adjust it or cut something else.

 **@CashQueen88:** Don't be scared to invest in yourself—courses, equipment, or tools that help you make more money in the future are worth the expense now.

 **@BudgetBro:** End game: spend less than you make, save smart, invest wisely, and expect surprise costs. That's how you actually hit your financial goals.

Questions

Answer the questions below using evidence from the text.

1) Why is it important to consider both income and expenses when setting financial goals?

2) What are some examples of expenses that could reduce profits from a business or job?

3) How do scaling expenses affect both income potential and expenses over time?

True or False

Is the statement true or false?

1) Step one is to figure out all your income sources.	T	F
2) Your gross income is more important than net income.	T	F
3) To reach a financial goal, you should understand your income and expenses.	T	F
4) Passive income is income you need to work hard to make.	T	F
5) Investing in yourself can help increase your income in the future.	T	F

Opinion

Write a comment that you would add to this conversation.

Username: _____ Date: _____

Gross vs Net Income

What is Gross Income?

Gross income is all the money you earn. For most people, their income comes from their work, but there could be other sources of income, such as lottery winnings, interest earnings, and the selling of assets and investments.



What is Net Income?

Net income is how much income is left after paying for non-negotiable expenses. For adults, taxes and retirement contributions are the most common costs.

Income Tax

Everyone pays income tax. **Income tax** is a percentage of income that is paid to the government. The more income you earn, the more income tax you will pay.

An Example

For example, if the average Canadian earns \$54,000 in gross income yearly. Earning this much means you will pay \$12,113 in income tax. This means the average Canadian takes home \$41,887 in net income. The average Canadian with a gross income of \$100,000 will pay \$27,084 in tax for a net income of \$72,916.

Questions

Answer the questions

1)	Alex earned \$38,413 from his employment. He also won \$12,000 from the lottery. He paid \$9340 in taxes. What is his net income?	
2)	Robert earned \$79,575 from his job. He sold a house and made an additional \$95,350. He paid \$53,538 in taxes. What is his net income?	
3)	Suzanne earned \$145,094 from her salary and from selling a house. She decided to contribute \$45,095 towards her retirement to put her net income under 100,000. She paid \$27,084. What is her net income?	
4)	Claire has her own business that earned \$278,500 last year. She paid \$100,000 in business expenses and paid the rest of the money to herself. In the end, she paid \$51,320 in taxes. What is her net income?	
5)	Zack earned \$134,048 from his job and from selling 500 shares of a stock he owned. He contributed \$25,000 to his retirement. His net income is \$81,304. How much income tax did he pay?	
6)	Willow earned \$51,530 from her job, \$34,520 from her side business and she sold stocks she owned for \$41,430. She paid \$42,405 in taxes. How much gross income did she earn?	
7)	John is a professional athlete who earned \$6,450,000 last year. He also earned \$850,000 for endorsements he did. He paid \$3,712,084 in taxes last year. How much net income did he earn?	

Income Tax – Gross/Net Income

Income Tax

You will pay more income tax when you earn more gross income. The table shows how much income tax on average is paid for each income tax bracket.

Although this is not exactly how accountants determine how much income tax you pay, it gives a good idea of how income tax works. In actuality, if you earn \$70,000, you will pay 7.5% on \$20,000, 15% on \$20,000, 21% on \$30,000, and 24% on \$10,000.

To get a better idea, you can use the average tax rates provided in the table. If you earned \$83,540, you would pay \$20,290.40 in income tax. This would result in a net income of \$63,249.60.

Gross Income Bracket	Avg. Tax Rate
\$0 - \$20,000	7.5%
\$20,000 - \$40,000	15%
\$40,000 - \$60,000	21%
\$60,000 - \$80,000	24%
\$80,000 - \$100,000	26%
\$100,000 - \$150,000	28%
\$150,000 - \$250,000	31%
\$250,000 - \$500,000	34%
\$500,000+	50%

Questions

Determine the amount of income tax that would be paid and the net income.

	Gross Income	Income Tax	Net Income
1)	\$95,542	\$20,290.40	\$75,251.60
2)	\$42,826		
3)	\$91,542		
4)	\$105,635		
5)	\$474,268		
6)	\$3,547,852		

Word Problem

Answer the question below.

Peter owns a company that made high earnings last year. He ended up earning \$273,049 but doesn't want to pay too much tax. He is debating contributing some money to his retirement so that he can bump down to the next lowest tax bracket.

- | | |
|--|--|
| a) How much will he need to contribute to his retirement to bump down? | |
| b) How much tax would he pay if he does contribute? | |
| c) How much will he pay if he doesn't? | |
| d) How much will he save on his taxes? | |

Exit Cards

Cut Out Cut out the exit cards below and have students complete them at the end of class.

Name: _____

Mark

a) Determine how much income tax would be paid and the net income

	Gross Income	Income Tax	Net Income
1)	\$82,500		
2)	\$10,000		
3)	\$2,240,800		

b) Maria made \$107,200 this year. She saved up \$10,000 for retirement and wants to use it to reduce her tax payment.

- i. If she applies the \$10,000 contribution, which bracket would she fall into?
- ii. How much tax will she save by moving into a lower bracket?
- iii. What will be her new net income?

Name: _____

Mark

a) Determine how much income tax would be paid and the net income

	Gross Income	Income Tax	Net Income
1)	\$82,500		
2)	\$610,000		
3)	\$2,240,800		

b) Maria made \$107,200 this year. She saved up \$10,000 for retirement and wants to use it to reduce her tax payment.

- i. If she applies the \$10,000 contribution, which bracket would she fall into?
- ii. How much tax will she save by moving into a lower bracket?
- iii. What will be her new net income?

Evaluating Financial Plans

Questions

Read the profiles below and calculate if they met their financial goals.

1) Emily is trying to save \$12,000 for college next year. She has 12 months to achieve her goal. Here are the details of her year long journey to achieve her financial goal.

- She earns \$1800 gross income a month from her employer
- She pays \$300 in taxes per month
- She is on a budget, spending \$75 a week
- She needs to pay \$1800 for a dental procedure

Did she reach her financial goal of \$12,000?

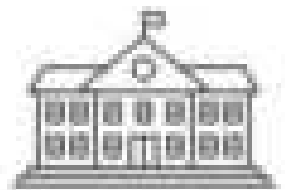

2) Jason wants to buy a drum set for \$2500. He hopes to buy the drum set in the next 20 weeks. He has a financial plan below.

- He will find a job that pays \$12.50 an hour. He will work 10 hours a week.
- He will go out for lunch 2 times a week at \$5 each lunch
- He is planning to buy his drum set in 20 weeks. Drums sets worth \$125 each.

a) Will he reach his financial goal of \$2500?

b) If Jason decided to work 12 hours a week, would he reach his goal? How much would he save?



3) Anthony wants to retire in 30 years. He is 25 right now. He wants to have \$2,000,000 in savings when he retires. His financial plan is listed below.

- He earns \$92,430 a year in gross income from his job
- He earns \$500 a month in dividends from his investments
- He earns \$300 in rental income from his rental property each month
- He pays \$27,302 in income tax each year
- He is on a budget, spending \$3,000 a month on expenses (house, car, phone, etc.)

a) Will he save \$2,000,000 by the time he is 55?

b) Oh no, at the age of 45, Anthony's expenses increased to 4,000 a month because he now spends \$1,000 on a medical issue. Will he still reach his financial goal at the age of 55?

Role Play: Financial Planning Role Play

Objective What are we learning about?

Practise financial decision-making, budgeting, and communication skills by acting out real-life financial situations that include income, expenses, and tax considerations to reach a long-term financial goal.

Materials What you will need for the activity

- Scenario cards for role play
- Simple protractor



Instructions How to do the activity

1. Divide the class into small groups. Assign each group a financial scenario card that includes a financial goal, income, expenses, and possible tax implications or deductions.
2. Have each group read their scenario and discuss the following questions: What is the financial goal? What are the sources of income? What are the expenses? How do taxes or deductions affect the plan? What changes are made to reach the goal?
3. Give each group time to create a simple financial plan showing how they reach their goal while balancing income, expenses, and taxes.
4. Allow groups time to rehearse their role play and encourage them to include problem-solving strategies such as cutting expenses, finding extra income, or adjusting timelines.
5. Have each group perform their role play for the class, demonstrating how they make decisions to reach their financial goal.
6. After all performances, hold a class discussion where each group explains how they balanced income, expenses, and taxes, the changes they made to their plan, the challenges they faced, and how their decisions affected their ability to reach their financial goal.

Scenario Cards

Cut out the scenario below.

Role-Playing Scenarios

Starting a YouTube Channel - You want to grow a gaming channel to 10 000 subscribers in one year. Your income comes from ad revenue and sponsorships, but you also have expenses like equipment, editing software, and internet upgrades. You must plan how to invest in your channel without overspending.

Saving for a Sports Tournament Trip - Your basketball team has qualified for a national tournament in another province. You need to save \$1 800 for travel, hotels, and food. You earn money from part-time refereeing, but also spend on sports gear and streaming subscriptions. Plan how to save enough in six months.

Buying a New Smartphone - Your current phone is slow, and you want the latest model for \$1 400. You earn money from tutoring and dog walking. Expenses include school lunches, bus fares, and streaming subscriptions. You must budget carefully while considering sales events. Should you buy now or wait for a sale?

Starting a Sneaker Resale Business - You want to buy limited-edition sneakers to resell for profit. You have \$200 to start and a weekly allowance, but you also spend money on clothing, gaming, and concert tickets. You need to plan purchases to maximise profit while managing expenses.

Planning a Concert Trip - Your favourite band is performing in a nearby city. Tickets, travel, and merch will cost \$450. You earn money from lawn care and online tutoring, but also have expenses like Netflix, gym fees, and birthday gifts for friends. Plan how to afford the trip in three months.

Launching a Small Clothing Brand - You and a friend want to start a brand of hoodies. You'll need to pay for materials, printing, and marketing. You earn income from part-time work at a café, but also spend money on transportation, gaming, and takeout. Plan to make a profit in four months.

Upgrading Gaming Setup - You want a new monitor, chair, and headset costing \$800 total. You earn from streaming tips and weekend work at a snack bar. You also have expenses like a phone plan, school trips, and snacks. Plan to reach your goal in five months without using credit.

Planning a Summer Business - You want to start a summer lawn care and dog walking business. You'll need to buy equipment and promote your services. You earn income from odd jobs but also spend money on clothes, outings with friends, and your gym membership. Create a plan to save for startup costs and still make a profit.

Tips For Reaching Goal

General Tips for Making and Managing Money

Tip	Explanation
Increase Your Earnings Over Time	Take on more customers, add extra hours, or offer new products/services to grow income steadily.
Set the Right Price	Charge enough to cover costs and make a profit, but not so high that customers choose competitors.
Balance Quality and Quantity	Work efficiently to take on more jobs, but keep quality high so customers return.
Use Bulk Buying for Savings	Buy supplies in bulk to reduce costs, but only if you can use them before they go to waste.
Offer Extras or Upgrades	Add just enough extras so customers will pay more for, increasing revenue without too much added expense.
Save a Portion of Every Payment	Put aside a fixed percentage of all income so savings grow steadily toward your goal.
Avoid Spending All New Income	Increase earnings without increasing expenses at the same rate to reach your goal faster.
Plan for Busy and Slow Periods	Save more during busy seasons to cover expenses during slower times.
Reinvest Wisely	Spend part of profits on better tools, ads, or training to help earn more in the future.
Track Your Progress	Record money earned, spent, and how close you are to meeting your financial goal.

Two Stars And A Wish

Identify two strengths (stars) and one area for improvement (wish) about your classmate's performance.

Write two strengths and one weakness of your classmate's performance.

PREVIEW



Interview with Financial Planner – Balancing Budgets

Kid: Hi! I'm here a Financial Planner. Can you explain what "balancing a budget" means?

Financial Planner: Sure! Balancing a budget means making sure your income (the money you earn or receive) is equal to or greater than your expenses (the money you spend). In Canada, about 1 in 3 households spends more than they earn, which can cause financial stress.

Kid: So what exactly counts as income?

Financial Planner: Income can be wages, salaries, commission, tips, investment returns, profits from a business, or even interest earned from savings. For students, income might come from part-time jobs, tutoring, or online selling.

Kid: What are expenses?

Financial Planner: Expenses are regular payments that stay the same each month—like rent, insurance, or subscription payments. They're predictable, which makes them easier to plan for. Expenses vary by household but should be no more than 50% of your monthly income.

Kid: And variable?

Financial Planner: Variable expenses change month to month. These include groceries, clothing, entertainment, and utilities. Because they're flexible, they're usually the first place to cut back if you need to.

Kid: How much should I save?

Financial Planner: A common rule is the "50/30/20 rule": 50% for needs, 30% for wants, and 20% for savings. For savings, aim for at least 10% of your income. You can go into an emergency fund, short-term goals, or long-term investments like Registered Retirement Savings Plans (RRSPs) or TFSA's (Tax-Free Savings Accounts).

Kid: What's an emergency fund?

Financial Planner: It's money set aside for unexpected events—like medical expenses, or car repairs. Financial advisors suggest having 3 to 6 months' worth of living expenses in your emergency fund.

Kid: How do you track all of this?

Financial Planner: You can use spreadsheets, apps, or even paper. Budgeting apps like Mint, YNAB, or PocketGuard automatically categorize your spending. Spreadsheets give you more control to customize categories and watch trends over time.

Kid: What happens if my budget isn't working?

Financial Planner: That's normal! Budgets aren't set in stone. If you overspend in one category, adjust your next month's plan. For example, if you spent \$50 extra on clothes, you might cut \$50 from entertainment. It's about finding balance.

Kid: What's your best advice for teens starting to budget?

Financial Planner: Start small. Track your spending for one month to see where your money goes. Then, set a simple budget—decide how much to spend, save, and adjust as needed. And remember, a budget is a tool to help you reach your goals, not a punishment.



True or False

Is the statement true or false?

1. Fixed expenses are costs that stay the same each month.	True	False
2. Variable expenses change based on how much you use or buy.	True	False
3. A budget only tracks how much money you spend.	True	False
4. Budgeting tools can include apps, spreadsheets, and notebooks.	True	False
5. Adjusting your budget is not necessary if your income changes.	True	False

Questions Answer the questions below.

1) How can budgeting tools like spreadsheets or apps help manage money?

2) How could you start budgeting if you have no money?

Fill in the Blanks

Use the word bank to fill in the blanks.

spending

Spreadsheets

expenses

planning

saving

adjusted

1. Budgets should be _____ when income or expenses change.

2. Fixed _____ are costs that remain the same each month.

3. Tracking _____ helps identify areas to save money.

4. Budgeting includes tracking both spending and _____.

5. _____ are a useful tool for balancing budgets.

6. Financial management skills improve with practice and _____.

Name: _____

Balanced Budget

A **budget** is a plan that lists the money you earn and the money you spend over a particular length of time. Budgets help people plan how their money is used so they can avoid wasting money on things they don't need.

Part 1 Calculate your earnings

If your job paid you \$20 per hour, how many hours would you want to work?
Fill in the table below.

	Hours	Income (Earnings) (\$)
Hours per week		
Hours per month (30 days)		

Part 2 Brainstorm the amount of money you want to spend on each per month

Categories	Expected Money Spent in Each Category Per Month
Food	
Rent/Mortgage	
Entertainment	
Cars	
Clothing	
Phone/TV/Internet	
Other:	
Total	

Part 3 Calculate your earnings, expenses, and savings for the periods of time below

Categories	Income	Expenses	Savings
1 Year			
5 Years			
10 Years			

Name: _____



Kai's Budget

Kai is a high school student who wants to save money for university. As part of his financial plan, he has created a budget to outline his income and expenses.



Part 1 Calculate Kai's total net income for one month.

Income Source - Figures after taxes	Net Income Per Month
Allowance - \$10/hour - 40 hours a month	
Part-time job - \$15/hour - 10 hours a week (4 weeks a month)	
Gift money - \$200 - 4 times a month	
Total Net Income	

Part 2 Calculate Kai's total expenses for one month.

Category	Expenses Per Month
Food - \$8 a meal - 12 meals a month	
Clothing - 3 items a month - \$25 an item	
Entertainment - \$5 a day for 30 days	
Gas for car - 40L a month - \$1.35/L	
Total Expenses	

Part 3 Answer the questions below

1) Is Kai's budget balanced? Explain why or why not.

2) If Kai continues this budget for 4 years of high school, how much will he have saved for university?

Name: _____

41

Copyright © 2013
The McGraw-Hill Companies

Adult Budget

Brian has filled out most of his budget but needs help finishing it. Help him determine if he has a balanced budget.

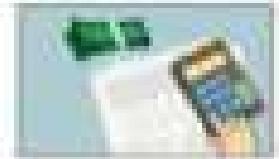

Part 1

Fill in the budgets – income and expenses

Income		
Pay Period	Income Taxes Owed (24%)	Net Income
2 Weeks		
4 Weeks		
6 Weeks		
26 Weeks		
1 Year		
Total 1-Year Gross Income		
Total 1-Year Net Income		

Expenses	
Rent/Mortgage	12000
Utilities	4000
Food	8000
Cars – Transportation	3000
Entertainment and Recreation	4500
Personal Care – Lifestyle	4200
Phone/Tv/Internet	2800
Miscellaneous	3000
Emergency Fund	5000
Total Expenses	
Total (Net)	

Part 2

Answer the questions below

1) Is Brian's budget balanced? Explain why or why not.

2) What is one thing that surprised you about Brian's budget?

3) Brian received a \$1,000 a month raise. Where should he put the extra money in his budget? Explain your choice.

Name: _____

Typical Wages and Salaries in Your Community

Perform some research to learn more about the wages and salaries for different jobs/careers in your community. Wages are hourly rates, whereas salaries are how much income people earn per year.

Research

Fill in the table by researching different jobs in your community.

Job/Career	Wages/Salary	Your Thoughts on the Income
Firefighter	\$85,085	"Firefighting is a tough job, so they earn their salary. Maybe I should consider firefighting as they make a good income"

PREVIEW

Name: _____

Create Budget Using Your Research – (1)

Use one of the jobs/careers you researched to fill in the budget below.



Part 1 Fill in the budgets – income and expenses

Income			Expenses	
Pay Period	Income Tax Owed (if unsure call tax 25%)	Net Income		
2 Weeks				
4 Weeks				
6 Weeks				
26 Weeks				
1 Year				
Total 1-Year Gross Income				
Total 1-Year Net Income				
			Total	
			Savings (Income	

Part 2 Answer the questions below

1) Is your budget balanced? Explain why or why not?

2) Which decisions were hard about balancing your budget? Which expenses did you have to spend less on than you wanted to?

Introduction to Interest

What is Interest?

Interest is the amount of money earned from an investment or the cost of borrowing based on an interest rate.

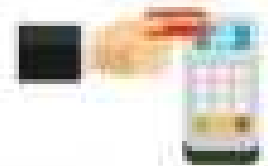

Interest From Investments

We can earn interest on our investments, which means we are putting our money to work! If we invest \$100 in the stock market, we hope that one hundred dollars is worth more at the end of the year. The average interest rate return in the stock market over the last 100 years is about 10%. This means that after one year, your \$100 is now worth \$110.

Interest From Borrowing

Most people are required to borrow money to pay for things like cars, houses, or even water and electricity household necessities. When we borrow money, we pay the lender (usually a bank) an amount we pay in interest depends on the interest rate. A higher interest rate will mean we pay more back in interest. For example, if we borrow \$100 with a 15% yearly interest rate, we will pay \$15 at the end of the year. It is important to shop around for the lowest interest rate.

Part 1

A bank pays 5% interest on your savings account - \$5 per \$100

Savings	Savings + Interest	Savings	Savings + Interest
1) \$200	\$205.00	5) \$1,000	
2) \$425		6) \$1,225	
3) \$650		7) \$1,450	
4) \$875		8) \$1,675	

Part 2

You pay 19% interest on your credit card - for every \$100 you pay \$19

Debt	Debt + Interest	Debt	Debt + Interest	Debt	Debt + Interest
1) \$500	\$595	4) \$979		8) \$4629	
2) \$655		5) \$1162		9) \$6017	
3) \$827		6) \$1375		10) \$8659	

Part 3

Answer the question below

What are your thoughts on interest? Is paying a 19% interest rate fair?

Memory Game: Interest Version

Objective

What are we learning about?

To help students understand and remember key interest-related terms and examples by playing a matching card game.

Materials

What you will need for the activity

- Memory Game cards (provided)
- A flat surface, such as a table or floor, to lay out the cards



Instructions

How you will do the activity

1. Divide the class into groups of 3 or 4. Each group will receive a set of Memory Game cards (provided).
2. Optional: have students match the terms with their definitions before playing the memory game (with the cards facing up). This can be done as a class to review the terms and definitions. Take these up as a class to ensure everyone understands the matches.
3. Have each group lay all the cards face down in a grid on a table.
4. The students take turns flipping over two cards at a time, trying to find a matching term and its definition.
5. If a student finds a match, they remove those cards from the grid and keep them.
6. If the cards do not match, they are turned back over, and the next student takes a turn.
7. The game continues until all the cards have been matched.
8. After the game, review the terms and definitions with the class.
9. Discuss why these terms are important to understand interests.

Cards

List of terms related to interest.

Terms	Definition
Interest	Extra money earned from saving or investing your money.
Simple Interest	Interest earned only on the starting amount of money.
Principal	The original amount of money you invest.
Interest Rate	The percentage used to figure out how much interest you earn.
Savings Account	A place at the bank where you keep money and earn interest.

PREVIEW

Cards

List of terms related to interest.

Terms	Definition
Earned Interest	The amount of money you make from your savings or investment.
Investing	Putting your money into something (like a bank or stock) to make more money.
Percent (%)	A way to show an interest rate - for every 100.
5% Interest	If you save \$100, you earn \$5 in a year at this rate.
\$200 at 5% = \$210	A savings example showing \$10 earned in interest after one year.

PREVIEW

Cards

List of terms related to interest.

Terms	Definition
Compound Interest	Interest earned on the money you saved and the interest you already earned.
Annual Interest	Interest calculated once a year.
Savings Growth	For an increase in your savings, you need to earn interest.
Bank	A place that keeps your money safe and pays you interest for saving.
Future Value	The amount your money will be worth after earning interest over time.

PREVIEW

Reflection

Answer the questions below.

1) Which interest term or concept that you learned about today was most interesting to you?

2) How does compounding interest help you make better decisions about saving money?

3) What's the difference between a savings account and a CD? How is interest earned on it?

4) Why is the interest rate important when choosing where to save money?



Interest Rates

What are Interest Rates?

An **interest rate** is the percentage of money a lender (usually a bank) will charge you for you to borrow their money. You will need to pay the principal (the amount you borrowed), plus interest, which is an extra amount that makes it worth it for the lender to let you borrow money from them in the first place. If there was no interest, there would be no reason for the lender to let you borrow their money.

Examples of Interest Rates

Pretend your friend needs \$50 to buy a video game. You could be a nice friend and lend it to them for free, or you could charge them interest. The amount of interest you charge them will be the **interest rate**.

Most lenders have terms on the repayment of the loan. Most lenders charge an **annual interest rate**, which means you pay the percentage of the loan yearly. In this example, you could tell your friend that they will owe you 10% more each year if they don't pay back the loan. This would mean you would charge them an extra \$5 for borrowing the \$50 and they will owe you \$55 in one year.

Factors Affecting Interest Rates

Not all banks and lenders charge the same interest rate for borrowing money. That is why it is important to shop around for the best interest rate. The following factors impact how much an interest rate is.

- People with good credit will tend to get a lower interest rate. Having good credit means that you have a history of paying back your loans. A lender would likely charge a friend a higher interest rate if you were worried they wouldn't pay back the loan on time.
- The type of loan impacts the interest rate. A mortgage is a long-term loan for the purposes of buying a house. The lender does a lot of work to make sure the borrower can afford to pay back the loan. This makes the loan more secure for the lender. A typical mortgage interest rate is between 2% and 4%.
- Credit card loans are riskier because it is easier to sign up for a credit card than to qualify for a mortgage. Credit card loans are often not paid back on time, which means the lender is out the money they lent out. This means they need to charge a higher interest rate, usually between 15%–25%.
- Where you get the loan will also affect the interest rate. If you go to a bank, you will likely get a fair interest rate. Banks are regulated by the Canadian government, which means they abide by rules setup to protect people who borrow money. You can also get loans in the form of a "Payday Loan", which are usually short-term loans that are paid back when someone gets paid from their employer. These loans can be dangerous, as they are much more expensive than credit cards and other loans offered from the bank. For example, a payday loan of \$300 for 2 weeks will cost you \$45 extra. The same loan using a credit card would cost you \$6.35.



True or False

Circle whether the statement is true or false

1) All interest rates are the same regardless of who you are borrowing from	True	False
2) Riskier loans have lower interest rates	True	False
3) People with good credit usually get better interest rates	True	False
4) Credit cards have lower interest rates, between 2% and 5%	True	False
5) Payday loans are expensive, with high interest rates	True	False

Making Connections How did the reading remind you of in your life?

Questions

Answer the questions using evidence from the text

1. Why is it important to shop around for the best interest rate?

2. Why do people and banks charge an interest rate?

Calculating Simple Interest

When we borrow money, we usually pay interest on the total amount we borrow. We call this amount the **principal**. Depending on the type of loan, the interest rates will vary.

Simple interest is interest paid on the principal amount. We can calculate simple interest by using the following formula:

Simple interest = principal \times interest rate \times time to pay back the loan.

This will give us how much interest we will pay for our loan.



For example, you owe \$5000 for a car loan with a 5% simple interest rate on a 5-year term. The amount of interest you will pay after the 5 years is $5000 \times 0.05 \times 5 = \1250 .

Part 1 Use the table below to determine the cost of borrowing for 3 and 8 years.

#	Principal	Interest Rate	3-Year Loan	8-Year Loan
1)	\$2000		\$300	\$800
2)	\$3500			
3)	\$6000	19%		
4)	\$10,000	8%		
5)	\$17,500	10%		
6)	\$25,000	4%		
7)	\$47,500	3.5%		

Part 2 Answer the questions below.

1) Is it more or less costly to borrow money for longer periods of time. Explain why that might be the case.

2) Jake is borrowing \$8000 for a new car. The interest rate is 6%. He's not sure if he'll choose the 5- or 7-year term. How much will he save in interest on the 5-year term?

Calculating Simple Interest

Questions

Answer the questions below

1) If you borrow \$750 for 5 years with an annual interest rate of 8%, how much interest will you pay?

a) How much in total will you pay?



2) How much interest will you have to pay if you borrow \$525 for 2 years at a 12% annual interest rate?

3) If you borrow \$2170 for 3 years with an annual interest rate of 6%, how much interest will you pay?

a) How much will you pay in total?



4) If you get a mortgage loan for \$225 000 to buy a house with an annual interest rate of 2.56%, how much interest will you pay for a 25-year loan?

a) How much will the house end up costing you?



5) Ivy paid \$72 of interest when she borrowed \$800. Her father said she paid 9% interest, but she says she had to pay 12%. Who is correct?

Simple Interest vs Compound Interest

Overview - Simple Interest vs Compound Interest

Simple interest is based on the principal amount of the loan or deposit. This means the interest paid does not change. For example, if you borrow \$100 at a 5% annual interest rate, you will owe \$5 in interest each year until the loan is paid.

Compound interest is based on the principal amount and the interest that accumulates on it every period. For example, if you borrow \$100 at a 5% annual interest rate, you will owe \$5 after the first year, a total of \$105 the next year (\$5.25). The third year, you would owe \$110.25, which is \$5.51.



Question: Which graph display a simple or compound interest loan?

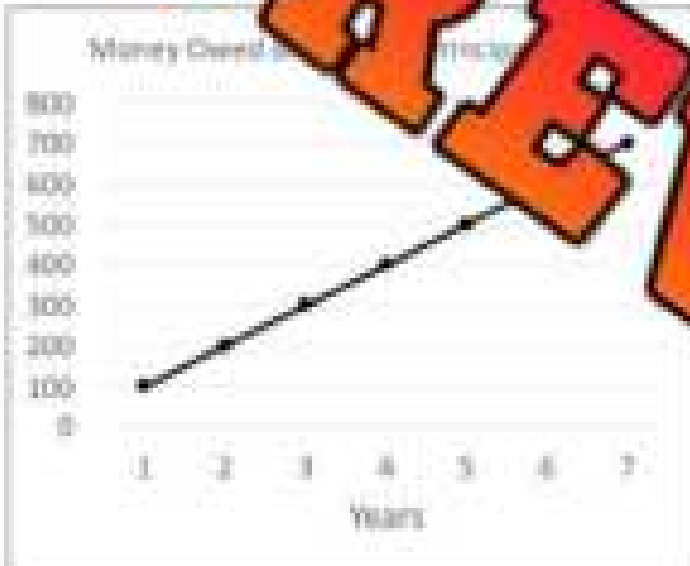

1) How do you know which type of loan this was? Explain.

2) How much interest will be paid after 7 years?

3) With what type of loan is a massive amount of interest being paid?

1) How do you know which type of interest is being applied? Explain.

2) What do you notice about the graph? Why isn't it linear?

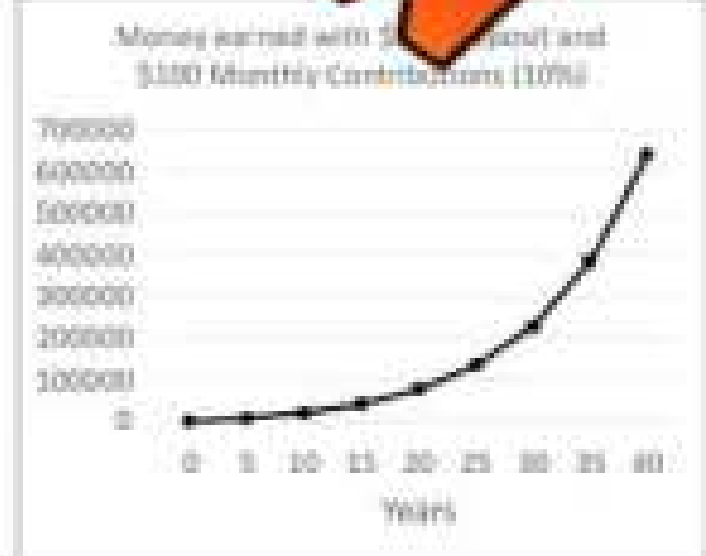

Compound Interest - Investing

When we invest money, we hope it will grow over time. The longer we leave an investment, the more interest the initial investment will earn, which leads to it being worth more. For example, if an initial investment of \$1000 grows 15% in a year, it will earn \$150 and be worth \$1150. If the investment keeps growing at 15% a year, the following year it will earn \$172.50 and will be worth \$1322.50.

Over the course of many years, an initial investment can grow to become a large amount! This is called compound interest, which Albert Einstein coined the "8th wonder of the world!"



Question: Calculate how much the initial investment grows after 5 years.

#	Initial Investment	1-Year 10% Total	2-Year 10% Total	3-Year 10% Total	4-Year 10% Total	5-Year 10% Total
1	\$200			\$266.20	\$292.82	\$322.102
2	\$750					
3	\$1000					
4	\$1,500					
5	\$2,100					
6	\$3,500					
7	\$72,000					
8	\$115,000					
9	\$150,000					
10	\$500,000					

Compound Interest - Borrowing

When we borrow money, we pay interest on how much we borrow. We need to consider how long it will take to pay back the debt before we decide to borrow. Borrowing money to buy things like a house or car are essential for most people even though those debts will take a long time to pay off. Luckily, mortgage interest rates are between 2-4% and car loans are typically around 5%.

On the other hand, borrowing to buy things we don't need can lead to us using credit cards to borrow. Credit cards have a 19% interest rate. Complete the table to see how credit card debt can become overwhelming with compound interest.



Question: How much interest is paid after borrowing for up to 5 years?

#	Principal Borrowing	1-Year 19%	2-Year 19% - Total	3-Year 19% - Total	4-Year 19% - Total	5-Year 19% - Total
1	\$100			\$168.52	\$200.53	\$238.64
2	\$250					
3	\$700					
4	\$1250					
5	\$2000					
6	\$2500					
7	\$2800					
8	\$3250					
9	\$5000					
10	\$15,000					

Compound Interest – Online Tool

Calculating compound interest is a complicated process. Fortunately, we can use online compound interest calculators to help us with the math. Using these tools helps us understand the importance of compounding interest, as it can get us in a lot of debt or earn us a lot of money.

Directions:

- 1) Search online: compound interest calculator
- 2) Type in the values from the table below to determine how much your investment or debt will grow
- 3) Use the calculator to determine how much interest is compounded monthly for all your results

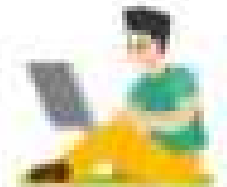

Part 1

Use the table below

#	Principal (Initial investment or borrowing amount)	Monthly Contribution	Interest Rate	Years to Grow	Total Value of Debt or Investment
1	\$100	\$100	10%	45	
2	\$500	\$50	10%	40	
3	\$2000	\$200	10%	35	
4	\$25	\$25	10%	30	
5	\$5000	\$100	9%	30	
6	\$8000	\$250	8%	25	

Part 2

Answer the questions below

1	What amount could you contribute now and each month? How much would you have in 40 years if you started today assuming a 10% return?	
2	Alex and Jeff are both 14 years old. Alex plans to contribute \$10 today and \$25 every month for the next 40 years. Jeff has more money now, so he will contribute \$2000 today, but only \$20 each month for the next 40 years. Assuming a 10% interest rate, who will earn more?	
3	Sam has two options for a compound interest loan. Option A is borrowing \$500 for 5 years with a 7% interest rate and option B is borrowing \$500 for 4 years with an 8% interest rate. Which will cost him more money?	

Compound Interest – Online Tool

Use an online compound interest tool to learn more about how you can reach different financial goals.

For example, to earn \$250,000 in 25 years, you could invest \$0 initially and add \$200 each month. At the end of the 25 years, you'll have \$267,578 with a 10% interest rate.



Part 1

Fill in the table with the minimum amount of contributions needed to reach the goal. Do not use an interest rate above 10%.

#	Principal (Initial investment or borrowing amount)	Regular Monthly Additions	Interest Rate	Investment Exact Value
1	\$2000	25	10%	\$2,117
2	\$3000			
3	\$25,000	7		
4	\$50,000	10		
5	\$100,000			
6	\$200,000			
7	\$500,000			
8	\$750,000			
9	\$1,000,000			
10	\$10,000,000			

Part 2

Answer the questions below

1) What did you learn about compound interest? Can small regular investments make a big difference in your savings?

2) If you invested the cost of a drink each day (\$2.50/day) for 30 years with an interest rate of 10%, how much would you have in 30 years?

Customer Loyalty and Incentive Programs

Incentive Programs

Businesses will do anything to sell more of their products and services. One popular marketing strategy is to offer incentive programs. An **incentive program** is designed to give rewards to customers to encourage them to buy or use their products or services.

Examples of incentive programs are:

- Free shipping
- Special sales - "Dollar Days" or "No Tax Days"
- BOGO - Buy one, get one free
- Give something and receive a ticket to enter a giveaway



Customer Loyalty

Customer loyalty programs are used by businesses to get repeat business from customers. They are a form of incentive program. A **customer loyalty program** rewards customers with freebies or discounts on future purchases. For example, Best Coffee Café gives 1 free coffee for every 10 coffees purchased.

It is very important for businesses to get repeat business. Studies have shown that acquiring a new customer costs 5-25x more than re-selling to a current customer. Also, it was found that existing customers spend 67% more than new customers. This is likely because existing customers know the business because they already have an experience with it.

Both the customer and the business benefit from using customer loyalty programs. The business benefits by having a customer base who will buy over and over. They may earn less per sale if they give discounts, but they make up for it with a larger volume of sales. The customer benefits by getting things they want at a lower price. They get them more value for their money.

Examples of customer loyalty programs are:

- **Reward Programs** - At Starbucks, customers earn stars when they spend money. They can use these stars to get free items.



- **Points Programs** - Many grocery stores, gas stations, and credit cards offer points programs. When you spend a dollar in many of these establishments, you get 1 point. You can redeem these points for free items from a catalogue, or for money to be used at their business.
- **Tiered Loyalty Programs** - Sephora's Beauty Insider program offers a tiered loyalty program. The more money you spend, the better the rewards you receive as you move up the tiers. At Sephora, members who spend \$350 enter the VIB tier where they get free gifts and one free makeover per year. If they spend \$1000 a year, they enter Rouge status with a private hotline and access to exclusive events.

Definitions

What do the terms below mean?

Term	Definition
Incentive Program	
Customer Loyalty Program	

Questions

Answer the questions below

1) Why is it important for a business to get repeat business from customers?

2) What is an example of a customer loyalty program and why does this program work?

Making Connections

Write about one customer loyalty program you have taken part in. How did you benefit from it and how did the business benefit?



Exit Cards

Cut Out

Cut out the exit cards below and have students complete them at the end of class.

Name: _____

Mark

/5

Is the statement true or false?

1) Incentive programs are only made to reward employees for meeting sales goals.	T	F
2) A "Buy One, Get One Free" deal is an example of a customer loyalty program.	T	F
3) In a points program, you must always redeem your points for cash.	T	F
4) Acquiring new customers is generally more expensive than keeping existing ones.	T	F
5) In Sephora's loyalty program, spending more leads to better rewards and access to exclusive services.	T	F

Name: _____

Mark

Is the statement true or false?

1) Incentive programs are only made to reward employees for meeting sales goals.	T	F
2) A "Buy One, Get One Free" deal is an example of a customer loyalty program.	T	F
3) In a points program, you must always redeem your points for cash.	T	F
4) Acquiring new customers is generally more expensive than keeping existing ones.	T	F
5) In Sephora's loyalty program, spending more leads to better rewards and access to exclusive services.	T	F

Evaluating Customer Loyalty Programs

Participating in customer loyalty programs has its advantages and disadvantages. When we use these programs to buy things we need, these programs are helpful in us getting more value for our money. But, when we are encouraged to spend money on things we wouldn't have normally bought, we may waste our money and regret not saving it.



Scenarios

Explain if the person should participate in the loyalty program or not.

<p>Scenario 1</p>	<p>Stella has bought a coffee from a coffee shop every day for the last 10 days. Today, she is offered a stamp card where if she buys 10 coffees, she gets one free.</p>
<p>Should Stella join? Explain.</p>	<p>_____</p> <p>_____</p> <p>_____</p>
<p>Scenario 2</p>	<p>Jacob just bought a hat from a new store he visited. They offered him 5% off if he uses it in the next 10 days.</p>
<p>Should Jacob make sure to use his 5% off in the next 10 days? Explain.</p>	<p>_____</p> <p>_____</p> <p>_____</p>
<p>Scenario 3</p>	<p>Emily travels a lot for work. She refills her gas tank every 10 days. Petro Canada offers a card that gives \$0.10 off every time she uses their gas stations.</p>
<p>Should Emily use the card and go to only Petro gas stations? Explain.</p>	<p>_____</p> <p>_____</p> <p>_____</p>
<p>Scenario 4</p>	<p>Ryan rarely stays in hotels, but he went to a Marriott Hotel yesterday. They offered him 100 points for every night he stays with them. If he gets 2000 points, he gets a free night stay.</p>
<p>Should Ryan join Marriott Hotel's loyalty program?</p>	<p>_____</p> <p>_____</p> <p>_____</p>

Research – Customer Loyalty Programs

Think of a brand and do some research into the customer loyalty program they offer. For example, search: "Nike Customer Loyalty Program" and you will discover that Nike has a membership program that offers you free shipping, workouts and training plans, as well as contact with Nike styling experts.



Research

Answer the questions below to complete your research

1) What brand/retailer did you choose?

2) How does the program work?

3) What benefits do customers receive from joining the program? Why would people join?

4) Do you think it is worth it to the customer to join the program? What are the advantages/disadvantages of joining the program?

5) Would you join this program? Explain your reasoning.

PREVIEW

Buying Second-Hand – More Value

Money is hard to earn, which means we should be careful when we spend it. Using these strategies can help you get more value for your money.

- 1) Taking part in customer loyalty and incentive programs
- 2) Waiting for things you need to go on sale
- 3) Purchasing second-hand items

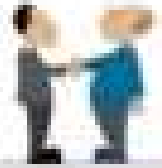

Questions Answer the questions below

1) Have you ever bought something second-hand? Did you get a good deal? Explain.

2) Where can you find second-hand items in your community?

3) If you were buying a used phone second-hand, what questions would you have for the seller?

4) How is buying things second-hand better for the environment?

5) Buying things second-hand can be sometimes unsafe. How could you ensure your safety when buying things second-hand?

PREVIEW

Choosing a Credit Card

Avion Travel Card

- Get 35,000 welcome points (value up to \$750)
- Earn 1 Rewards point for every dollar you spend
- Use Reward points to choose from a massive catalogue of awesome items
- 19.99% interest rate
- Cost per year: \$120
- No foreign currency conversion fee

Rewards+ Card

- \$0 yearly fee – that's right, free!
- Get 1,500 welcome Reward points
- Earn up to 3,500 additional Reward points by getting your monthly statements sent by email
- Earn 1 Reward point for every \$1 spent on gas, grocery, and drug store purchases
- Earn 1 Reward point for every \$2 spent on all other purchases
- Use Reward points to choose from a massive catalogue of awesome items
- 18.99% interest rate
- 3% foreign currency conversion fee

Decision Time!

If you were in each scenario, which account would you choose?

Scenario 1	Easton travels on a lot of business. He also drives to the United States once a month. He likes using a credit card there.
Which credit card should Easton choose?	<hr/> <hr/> <hr/> <hr/>
Scenario 2	Grayson travels a lot for his work. He goes on a lot of business, but he drives a lot. He complains he spends too much on gas. He mostly stays within Canada.
Which credit card should Grayson choose?	<hr/> <hr/> <hr/> <hr/>
Scenario 3	Autumn is looking for a card that won't cost her much. She likes the idea of getting rewards but is more interested in low fees.
Which credit card should Autumn choose?	<hr/> <hr/> <hr/> <hr/>

Name: _____

68

Business Economics
11.1

Pros/Cons

Write the pros and cons of both cards below

Avion Travel Card

Pros

Cons

Rewards Card

Pros

Cons

PREVIEW

Questions

Answer the question below

1. Which credit card would you choose? Explain your choice.

2. Do you think the rewards are as important as the interest rates? Explain.

Name: _____

Researching Credit Cards

Informed consumers do their research before making big purchases or before signing up for services, like credit cards. Do your research by comparing 2 different credit cards. Most banks offer their own credit card services. Search whichever bank you are most interest in.

Directions

- 1) Search online: (name of your bank) credit card offers
- 2) Fill in the tables below for 2 different credit cards



Research: Fill in the tables below to learn more about these credit cards:

Name of Credit Card #1	
Annual Fee	
Interest Rate	
Reward Points	
Other Offers	

Name of Credit Card #2	
Annual Fee	
Interest Rate	
Reward Points	
Other Offers	

PREVIEW

Create Credit Card Offers - Assignment

Assignment:

You are hired by a credit card company to make 2 credit card offers

You are hired by a credit card company to create 2 credit card offers that will make the company a lot of money, but will also entice customers to sign-up. Create two different offers, one with a higher annual fee and lots of rewards and one that is free with less rewards.

PREVIEW

1) Who should get the first option of credit card? Describe the benefits.

2) Who should get the second option of credit card? Describe the benefits.

Consumer Contracts

A **consumer contract** is when a customer signs an agreement with a business for them to provide a service to them in exchange for money. Examples of some popular consumer contracts are:

- Cell phone contracts
- Internet and TV
- Music and video streaming services
- Video games/apps



When customers sign a consumer contract, they are signing up for a pre-determined length of time. For example, the average consumer contract for a cell phone is a 2-year contract. When you sign a contract, you are agreeing to pay a pre-determined amount of money for the services. If you use more than the services outlined in our contract, we could charge extra charges need to be explained in the consumer contract.

It is important to shop around before signing a consumer contract. You should compare offers from different businesses to ensure you are getting good value for your money. Once you have signed a contract, you must stay out of the contract until the agreed upon date. Many music and video streaming services offer one-month contracts.

Questions

Answer the questions below.

1. Write down 5 specific consumer contracts that you have used in the past. (Example: Netflix)

2. Why is it important to shop around before signing a multi-year contract?

Task

Create a cell phone contract below. Fill in the details to finalize the contract.

Name of Cell Phone Plan	
Monthly Cost	
Amount of Data in GB	
Canada-Wide Calling	

International Calling	
Text, Video, and Photo Messaging	
Number of Years of Contract	
Free Offers Ex: Free tablet	

Exit Cards

Cut Out Cut out the exit cards below and have students complete them at the end of class.

Name: _____

Why do you think companies want people to sign long-term contracts? Do you think it benefits the company or the customer more? Explain.

Name: _____

Why do you think companies want people to sign long-term contracts? Do you think it benefits the company or the customer more? Explain.

Name: _____

Why do you think companies want people to sign long-term contracts? Do you think it benefits the company or the customer more? Explain.

Name: _____

Why do you think companies want people to sign long-term contracts? Do you think it benefits the company or the customer more? Explain.

PREVIEW

Research Cell Phone Plans

Research

Find 2 cell phone plans online and fill in the details of each plan below

Buying a cell phone from most companies requires customers to sign a 2-year contract. Before signing a contract, customers need to understand how they plan to use the phone so they can choose a plan that fits their needs.

Name of Cell Phone Plan #1	Name of Cell Phone Plan #2
Monthly Cost	Monthly Cost
Amount of Data in GB	Amount of Data in GB
Canada-Wide Calling Details	Canada-Wide Calling Details
International Calling Details	International Calling Details
Text, Video, and Photo Messaging	Text, Video, and Photo Messaging
Free Offers	Free Offers
Extra Details	Extra Details

PREVIEW

Pros/Cons

Write the pros and cons of both cell-phone plans below

Cell Phone Plan 1

Pros

Cons

Cell Phone Plan 2

Cons

PREVIEW

Questions

Answer the questions below

1) Who should get the first option of cell phone? Explain why.

2) Who should get the second option of cell phone? Explain why.

Name: _____

75

Financial Literacy – Unit Test

	US Dollar	Euro	Yen	Pounds	Australian Dollar
\$1 CAD	\$0.80	€0.70	¥90.00	£0.60	\$1.10

	1 USD	1 Eur	1 Yen	1 Pound	1 Australian Dollar
In CAD	\$1.25	\$1.43	\$0.011	\$1.70	\$0.92

Part 1 Convert the CAD to other currencies

	CAD	Other Currency	\$
1)	\$100	US Dollar	
2)	\$130	Pound Sterling	
3)	\$455	Australian Dollar	
4)	\$1200.52	US Dollar	
5)	\$1550.67	Pound Sterling	
6)	\$2698.53	Japanese Yen	

Part 2 Use \times or \div to complete the table

1)	\$25.00CAD		€450.00JPY	4)	\$285.46		\$209.79AUD
2)	\$29.50USD		\$35.65CAD	5)	\$170.00		€975.96JPY
3)	\$19.76CAD		\$23.61AUD	6)	\$1486.85		€710.56EUR

Part 3 How much will the item cost in CAD with a 3% conversion fee?

	Cost Purchase Price (P.P.)	Cost in CAD Apply Exchange Rate	3% Conversion Fee of P.P.	Total Cost
1)	\$25 USD			
2)	\$75.00 AUD			
3)	€5000.75 JPY			
4)	€285.46 EUR			
5)	€1486.85 GBP			

Part 4

Answer the questions below

1)	Charles earned \$63,500 from his job. He also earned \$12,500 from selling some investments. He paid \$11,343 in taxes. What is his net income?	
2)	Sofia earned \$52,750 from her job last year. She also earned \$1500 from her rental property each month. She paid \$18,300 in taxes. What is her net income?	
3)	Dexter earned \$72,670 from his job and \$18,345 from his side-job. He paid \$24,500 in taxes. What is his gross income?	
4)	Nicole earned \$204 from her job and she won \$375,324 from the lottery. She paid \$10,000 in taxes. What is her net income?	
5)	Lucas earned \$120,000 from his job. He also sold a rental property and earned \$10,000 from the sale. He paid \$12,712 in taxes. What is his net income?	

Part 5

Fill in the missing values in the table below

	Gross Income	Taxes	Net Income
1)	\$95,542		\$70,701.08
2)		\$42,000	\$126,154
3)	\$98,542	\$28,483	
4)		\$24,454	
5)	\$163,489		

Part 6

Calculate the cost of borrowing the principal for 3 and 8 years

#	Principal	Interest Rate	3-Year Loan	8-Year Loan
1)	\$3000	7%		
2)	\$4500	19%		
3)	\$7000	8%		
4)	\$12,000	5%		
5)	\$22,000	3.25%		

Part 7

Answer the questions below

1) If you borrow \$950 for 5 years with an annual interest rate of 8%, how much interest will you pay?

b) How much in total will you pay?

2) How much interest will you have to pay if you borrow \$725 for 2 years at a 12% annual interest rate.

Part 8

What do the following mean?

Term	Definition
Compound Interest	
Customer Loyalty Program	
Consumer Contracts	
Balanced Budget	
Gross Income	



Workbook Preview



Grade 8 D1. – Data Literacy

	Curriculum Expectations	Pages That Cover the Expectations
D1.1	identify situations involving one-variable data and situations involving two-variable data, and explain when each type of data is needed	8 - 10, 15,
D1.2	collect continuous data to answer questions of interest involving two variables, and organize the data sets as appropriate in a table of values	5 - 7, 11 - 14, 45, 47, 54, 56, 68, 73, 77, 83, 85
D1.3		8, 55, 76,
<p style="color: red; font-size: 1.2em; font-weight: bold;">Preview of 120 pages from this product that contains 279 pages total.</p>		
D1.4	create an infographic about a data set, representing the data in appropriate ways, including in tables and scatter plots, and incorporating any other relevant information that helps to tell a story about the data	93 - 98
D1.5	use mathematical language, including the terms "strong", "weak", "none", "positive", and "negative", to describe the relationship between two variables for various data sets with and without outliers	32 - 40
D1.6	analyse different sets of data presented in various ways, including in scatter plots and in misleading graphs, by asking and answering questions about the data, challenging preconceived notions, and drawing conclusions, then make convincing arguments and informed decisions	16 - 28, 41 - 44, 49 - 53, 58 - 67, 70 - 72, 75, 79 - 81, 99 - 118

One-Variable vs Two-Variable Data

A **variable** is any attribute, number, or quantity that can be measured or counted.

One-variable data has one set of data that could be qualitative or quantitative.

Examples

(1) Length of arm span for grade 8 students (2) Favourite movie of grade 8s

Two-variable data has two sets of data that could be qualitative or quantitative

Examples

(1) Relationship between a person's arm span and their height

(2) How many hours people read and their IQ levels

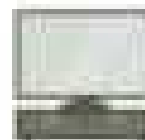

Part 1 Classify the following as one-variable or two-variable data? Use a checkmark ✓

	Example	One-Variable	Two-Variable
1)	Favourite sport of junior		
2)	Average temperature in Toronto each month		
3)	Length of arm span versus height of students		
4)	How far Liam ran each day last week		
5)	Mia's test scores and how much sleep she gets		
6)	How far you drive to work and how much time you spend on your job		
7)	Number of siblings each student has in your class		
8)	Relationship between screen time of students and homework completed		

Part 2 Write your own examples of one-variable and two-variable data

		Example
1)	One-Variable	
2)	One-Variable	
3)	Two-Variable	
4)	Two-Variable	

One-Variable vs Two-Variable Data

Directions: Does the graph represent one or two variables? Describe both variables.



1)	Does the graph represent one or two variables? _____
2a)	Describe variable number 1 _____
2b)	Describe variable number 2 (if applicable) _____

1)	Does the graph represent one or two variables? _____
2a)	Describe variable number 1 _____
2b)	Describe variable number 2 (if applicable) _____

Employment Sectors in Canada

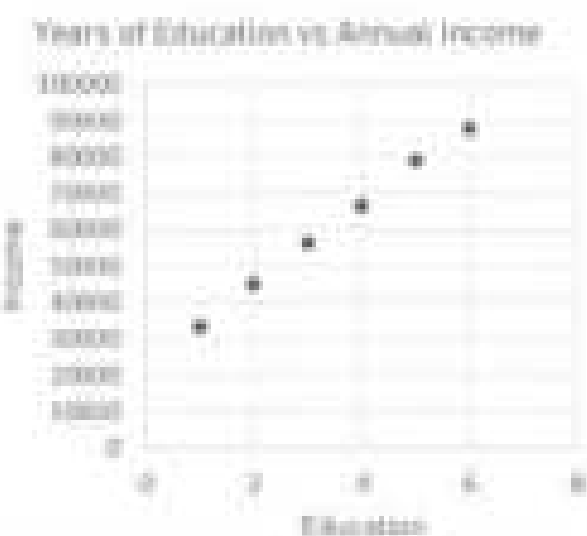
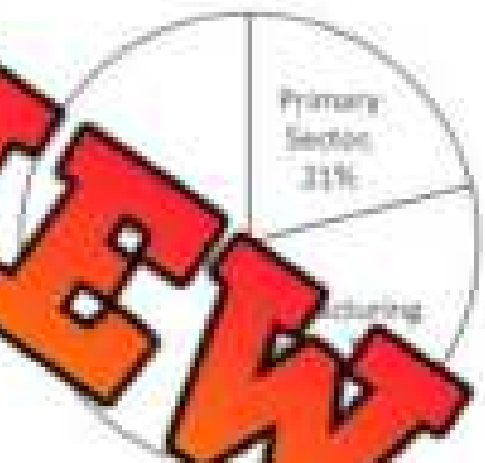

1)	Does the graph represent one or two variables? _____
2a)	Describe variable number 1 _____
2b)	Describe variable number 2 (if applicable) _____

Directions: Does the graph represent one or two variables? Describe both variables.

Beach Visitors

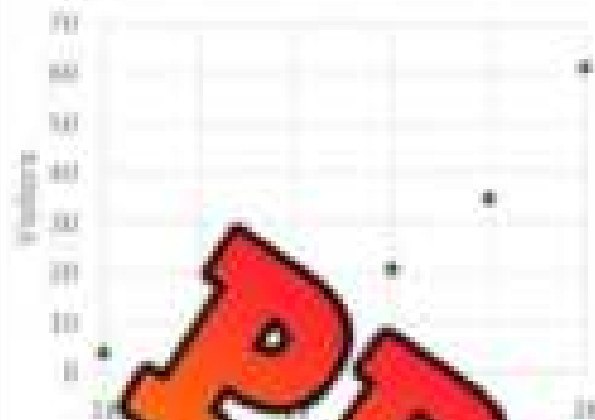

1)	Does the graph represent one or two variables?

2a)	Describe variable number 1

2b)	Describe variable number 2 (if applicable)

Distance-Time Graph - Race

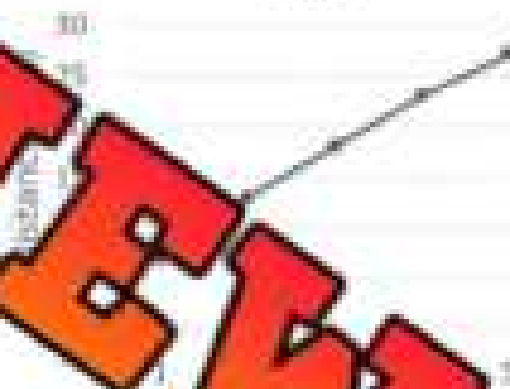

1)	Does the graph represent one or two variables?

2a)	Describe variable number 1

2b)	Describe variable number 2 (if applicable)

Tree Heights

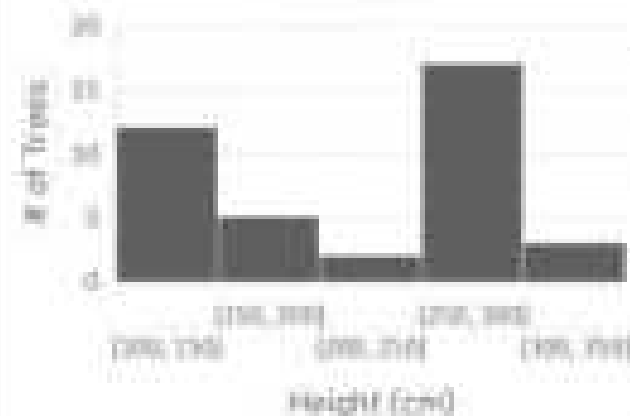

1)	Does the graph represent one or two variables?

2a)	Describe variable number 1

2b)	Describe variable number 2 (if applicable)

Representing Distribution Using Percentages

Why Use Percentages?

Percentages are used to show the distribution of a variable. Using percentages makes the data easier to read than simply just using the frequency.



For example: Which table is easier to draw conclusions from?

Ways I Get To Work	
Personal Vehicle	3558
Bike	231
Walk	752
Bus	459
Total	5000

Ways I Get To Work			
Personal Vehicle	3558	0.71	71%
Bike	231	0.05	5%
Walk	752	0.15	15%
Bus	459	0.09	9%
Total	5000	1.00	100%

Questions

Fill in the missing values using percentages and decimals.

1) Favourite Colour			
Options	Frequency	Decimal	%
Blue	3540		
Red	2123		
Pink	1575		
Green	3742		
Total			

2) Favourite Music Genre			
Options	Frequency	Decimal	%
Pop	312		
Rap	342		
Country	2940		
Total			

3) Top 50 Movies All Time - Genres			
Options	Frequency	Decimal	%
Comedy	11		
Action	15		
Drama	23		
Horror	2		
Total			

4) Best Season to Travel			
Options	Frequency	Decimal	%
Summer	12845		
Fall	5007		
Winter	24543		
Spring	7405		
Total			

Frequency Tables Versus Relative Frequency Tables

Frequency Tables Versus Relative Frequency Tables

A **relative frequency table** displays the percent of each option in a data set. These relative frequencies are calculated by dividing the frequencies for each option by the total number of frequencies for all options.

A **frequency table** only lists the frequencies belonging to each group. Frequency tables are harder to generate comparisons between options in a data set.

Questions Look at the tables. Is the table a frequency table or relative frequency table?

1) Number of Items Ordered Per Order			
Options	Frequency	Total	%
0	3		
1-2	99		
2-3	56		
4+	11		
Total			
Relative Frequency Table		Frequency Table	

2) How Many Trees On Your Property	
Options	Frequency
0	754
1-5	3145
6-10	6485
11+	9616
Total	
Relative Frequency Table	

3) Musical Instrument You Play	
Options	Frequency
Noise	154
Guitar	125
Piano	110
Other	111
Total	
Relative Frequency Table	

4) Type Of Vehicle			
Options	Frequency	Total	%
Car	36714		
Van	6485		
Truck	11452		
Motorbike	3349		
Total			
Relative Frequency Table		Frequency Table	

Discrete or Continuous Data?

Discrete and continuous data are both forms of quantitative data. This means both are numerical, meaning the data is acquired through counting or measuring.

Discrete data is collected when the answers to a survey are only numbers. It is quantitative data that has no relationship between the numbers. For example, "how many pets you have" is discrete data because there is no relationship between 1 and 2 pets. You cannot have 1 and a half pets, only 1 or 2. Discrete data is counted.

With **Continuous data**, there is a relationship between the numbers. For example, "how much rainfall there was last week?" You can have 1 and a half millimetres of rain, which means there is a relationship between 1 and 2. Continuous data is measured.

Part 1 How many variables from the research question be discrete or continuous?

Tip: Ask yourself if the data can be split in half.

Research Question	Discrete/Continuous
1) How many cousins do you have?	
2) Which subject is your favourite in school?	
3) How many minutes did you study for the test before the test?	
4) How many millimetres did your hair grow each month?	
5) How many books have you read in the last year?	

Part 2 How many variables does the data have? Is the data discrete or continuous or both?

Research Question	One/ Variable	Discrete/ Continuous/Both
1) How many homeruns a team scored last season		
2) How many steps you take in a day and how many calories you burn		
3) Most popular drink ordered at a café and what gender orders which drink		
4) Type of vehicle and its fuel economy		
5) Height of a dog and its weight over 5 years		
6) How many dunks a basketball player had last season		
7) Favourite music genre and what year you were born		
8) Practice time and results in a music festival		

MEAN

Mean = the average in a set of data

Step 1: Add up the numbers in the data set

Step 2: Divide the sum by the amount of numbers in the set.

Example:

Data set: 5, 6, 8, 5

Step 1: $5 + 6 + 8 + 5 = 24$

Step 2: $24 \div 4 = 6$

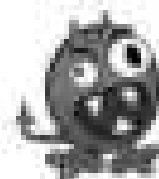

Part 1 Find the mean for each data set below

	Data	Total - Add Numbers	Mean
1)	14, 18, 16		
2)	41, 48, 45		
3)	121, 108, 129, 115		
4)	5.2, 6.8, 4.3, 7.7		
5)	12.5, 14.8, 15.7, 9		
6)	-5, -7, -9, -3		
7)	-22, -31, -28, -26		
8)	-78, -95, -141, -62		
9)	7, -8, 4, -11		
10)	3.8, -4.2, 2, -1.6		

Part 2 Answer the word problems below

1) Emma is trying to figure out her handicap in golf. A handicap is your average score. She golfed 10 times this year and had the following scores. What is her handicap?

-4, -8, 5, 4, -2, -5, 0, 7, -3, -4

2) Hudson recorded his screen time in minutes for the last 5 days. What was his average screen time for the last 5 days in minutes and hours?

147, 168, 262, 241, 197

Finding Missing Data Point Using Mean

We can determine the missing number in a series if we know the mean by using the following formula:

$$\text{Mean} = \frac{\text{Sum of given numbers} + (\text{unknown number})}{\text{total numbers}}$$

Example: 25, 27, ?, 30 Mean = 26

Steps

- 1) Multiply the number of total numbers you have by the mean ($26 \times 4 = 104$)
- 2) Add the numbers you know ($25 + 27 + 30 = 82$)
- 3) Find the difference (subtract) between 104 and 82 ($104 - 82 = 22$) – Answer = 22

Questions

Use the information below to find the missing data point.

	Data Set	Mean	Calculations	Missing Data Point
Ex)	9, 16, ?, 22, 12, 19	15	1) $15 \times 6 = 90$ 2) $9 + 16 + 22 + 12 + 19 = 78$ 3) $90 - 78 = 12$	12
1)	6, ?, 7, 13, 12, 11	11		
2)	27, 19, 14, ?, 53	29		
3)	37, 22, 48, ?, 62, 77	50		
4)	-8, -5, -13, ?	-8		
5)	-15, ?, 17, -17, -7	-2		

Finding Missing Data Point Using Mean

Questions

Answer the word problems below

1) The average temperature last week was -5°C . The temperatures for each day of the week have been represented in the table below. The table is missing the temperature for Friday. Calculate the missing temperature.

Day	Mon	Tues	Wed	Thurs	Fri	Sat	Sun
Temp		-7	-4	-8		3	-4



2) Gas prices for the last 10 days have an average of \$1.34 per litre. The prices for each day are listed below. Calculate the missing value for day 3.

Day	1	2	3	4	5	6	7	8	9	10
Price	1.31	1.45		1.36	1.2	1.3	1.4	1.24	1.22	



3) A diver plunged an average of -6.8m in her 8 dives last week. The depth of her dives are recorded in the table below, but her last dive is missing. Calculate the depth of her last dive.

Dive	1	2	3	4	5	6	7	8
Depth	-5.7	-4.2	-8.5	-7.4	-2.2	-6.7	-7.2	



Exit Cards

Cut Out Cut out the exit cards below and have students complete them at the end of class.

Name: _____

1) The mean depth for water dives is -4.8 m. Find the missing depth for Dive 4.

Dive	1	2	3	4	5	6	7	8	9
Depth	-5.9	-4.5	-6.8		-2.5	-3.8	-4.7	-5.6	-3.9

2) The mean daily price over the 9 days is $\$1.38$. Find the missing price for Day 4.

Day	1	2	3	4	5	6	7	8	9
Price	1.41	1.35	1.42		1.30	1.44	1.39	1.36	1.38

Name: _____

1) The mean depth for water dives is -4.8 m. Find the missing depth for Dive 4.

Dive	1	2	3	4	5	6	7	8	9
Depth	-5.9	-4.5	-6.8		-2.5	-3.8	-4.7		-3.9

2) The mean daily price over the 9 days is $\$1.38$. Find the missing price for Day 4.

Day	1	2	3	4	5	6	7	8	9
Price	1.41	1.38	1.42		1.30	1.44	1.39	1.36	1.38

Task Cards: Mean Detective

Objective

What are we learning about?

To help students understand and solve for a missing data point in a set by using the mean (average).

Materials

What you will need for the activity

- Task cards
- Student sheets for answers
- Pencils



Instructions

How to do the activity

1. Introduce the concepts covered in the task cards.
2. Organize the students into pairs and provide each pair with their sets of task cards.
3. Give each pair an answer recording sheet and pencils.
4. Encourage teamwork by having students collaborate on their problem-solving solutions.
5. Allow students to select any task card to begin with, emphasizing that they can complete the cards in any order they prefer.
6. Instruct students to record the letter of their chosen answer (A, B, or C) on their answer sheet beside the task card's number.
7. Consider using a timer to create a dynamic challenge, adjusting the duration to fit the lesson's objectives and complexity.
8. After the activity, review the answers collectively, discussing any challenging questions and strategies used to solve them.
9. Have students reflect on the activity, sharing the methods they applied and obstacles they overcame.

Task Cards

Cut out the task cards below

Card 1:

Find the missing value in the series: 45.2, 7, 48.6, 49.8, 44.1, 47.5, if the mean is 47.

- a) 46.8
- b) 46.5
- c) 46.0

Card 2:

The temperatures in a city over six days were: 14.5°C , 16.1°C , 13.9°C , 7, 17.3°C , 15.8°C . The mean temperature was 15.2°C . What was the temperature on the missing day?

- a) 14.9°C
- b) 12.6°C
- c) 14.7°C

Card 4:

The temperatures recorded over five days were: -3.5°C , -4.0°C , 7, -5.2°C , -3.9°C . If the mean temperature was -4.2°C , what was the missing temperature?

- a) -4.4°C
- b) -4.2°C
- c) -4.0°C

Card 5:

The mean of the numbers 11.5, 13.2, 14.1, 7, 13.7, and 12.8 is 13.2. Find the missing number.

- a) 13.5
- b) 12.5
- c) 13.9

Card 6:

Five players on a basketball team scored 22, 18, 20, 21, and 23 points. The average score of the team in a game was 20. What was the missing player's score?

- a) 19
- b) 17
- c) 23

Card 7:

A worker earned an average of \$450 per week over 6 weeks. His weekly earnings were \$470, \$440, \$455, \$465, and \$425. How much did he earn in the 6th week?

- a) \$445
- b) \$435
- c) \$450

Card 8:

The average distance of five runners in a run was 12.4 km. Four of the runners ran distances of 12.8 km, 11.9 km, 12.1 km, and 12.6 km. What was the missing runner's distance?

- a) 12.2 km
- b) 12.6 km
- c) 12.5 km

Task Cards

Cut out the task cards below

Card 17:

A baker baked an average of 120 cupcakes per week over 5 weeks. The cupcakes baked in four weeks were: 115, 125, 118, and 123. How many cupcakes did the baker bake in the fifth week?

- a) 122
- b) 120
- c) 118

Card 18:

The mean of the values 27.6, 29.9, 26.4, 24.8, and ? is 26.5. What is the missing number?

- a) 28.2
- b) 26.8
- c) 27.8

Card 20:

A business earned an average of \$-5,400 per week over 4 weeks, and their earnings in 3 of those weeks were \$-5,800, \$-5,200, and \$-5,600. What were their earnings in the missing week?

- a) \$-5,200
- b) \$-5,000
- c) \$-5,400

Card 21:

The mean of the numbers 48.9, 50.2, 49.1, ?, and 50.6 is 49.5. What is the missing number?

- a) 48.7
- b) 48.8
- c) 49.3

Card 22:

A class did a test and got a score of 72% in five tests. The scores were 75%, 70%, 74%, ?, and 73%. What was the missing score?

- a) 71%
- b) 72%
- c) 73%

Card 23:

A car traveled at speeds of 80, 75, 85, 82, and ? km/h over 5 hours. If the average speed was 81 km/h, what was the missing speed?

- a) 80 km/h
- b) 78 km/h
- c) 83 km/h

Card 24:

The average score of 7 players on a basketball team is 10.5 points. The points scored by 6 players are 9, 12, 11, 10, 8, and 13. How many points did the missing player score?

- a) 10.5
- b) 10
- c) 12

Task Cards: Mystery Mean Detectives

Answers Record your answers below

1	
2	
3	
4	
5	
6	
7	
8	
9	
10	
11	
12	

13	
14	
15	
16	
17	
18	
19	
20	
21	
22	
23	
24	

PREVIEW

Outliers in Data Sets

An **outlier** in a data set are values that are significantly different from other measures. They may mean that something has gone wrong in the data collection, or they may represent a valid measure that needs further explanation.

Part 1 Circle any outliers in the data sets below

1) 25, 30, 30, 3, 29, 36, 34, 71	4) -4, -8, -6, -21, -9, -7, 12, -5
2) 145, 150, 155, 160, 165, 170, 175, 179, 294, 147	5) -9.4, -29.6, -8.7, -7.9, -10.1, -9.6
3) 1.2, 1.4, 1.5, 1.6, 1.7, 1.8, 1.9, 2.0, 2.1, 2.2, 2.3, 2.4, 2.5, 11.4, 21.7	6) 1.1, 0.5, -0.4, -1.5, 1.3, -0.8, -24.2, 1.3

Part 2 Explain any outliers in the data sets below

1) Owen practiced his 400m freestyle. After the stopwatch that automatically record his times on a computer, he recorded the following times: 49.5, 52.3, 138.1, 51.7, 49.8, 51.2.

- Which of his scores was an outlier?
- What might have caused the outlier score?



2) Tony looked at how many steps he took last week. The number of steps he took over the last 7 days are recorded below:

11243, 13178, 9135, 20891, 12485, 3878, 14879

- Which of the values are outliers?
- Explain why he may have an outlier of 3878 steps?
- Why might Tony have an outlier of 20891 steps?



3) Chris owns a pizza shop. His profits for the last 7 days are listed below:

\$142, \$165, \$152, \$177, \$843, \$0, \$162

- Which of the values are outliers?
- Explain what could have led to Chris earning \$0 profits on day 6?
- Explain what could have led to Chris earning \$843 on day 5?



Calculating Mean - Outliers

Outliers have a big impact on the mean of a data set. For example, if John records his last 5 long jumps and jumps the following distances:

6.5m, 6.8m, 1.5m, 6.2m, 6.1m

John explains after that on his third jump, he slipped and didn't perform a full jump. The data set has an outlier that doesn't reflect John's ability to jump. We can see the difference when we use an outlier in our calculation of the mean.



Mean With Outlier: _____

Mean Without Outlier: _____

Part 1 Complete the table by calculating the mean with and without the outlier.

	Data Set	Outlier(s)	Mean Without Outlier(s)
1)	14, 16, 15, 68, 17		
2)	-5, -2, 38, -4, -6, -1		
3)	0.5, 0.8, -24.7, -0.4, 0.3		
4)	-16.7, 15.7, 13.9, 14.2, 16.4		
5)	-5.3, 13.4, -6.8, -6.1, -75.9		

Part 2 Answer the word problem below.

1) Explain what happened in question 5. Why was the mean similar even with the outliers?

2) Cole has been playing very well in golf. His last 10 golf scores are listed below.

-2, 18, 3, -4, -1, 1, 4, -6, -4, -3

a) What is his handicap over the last 10 games?

b) If he removes the outlier, what would his handicap be?

Calculating Mode and Median - Outliers

Part 1

Calculate the mode using the outlier(s) and without the outlier(s)

	Data Set	Mode With Outlier(s)	Mode Without Outlier(s)
1)	11, 10, 13, 17, 25, 68, 21, 12, 11, 10		
2)	138, 144, 144, 144, 138, 144		
3)	15.8, 15.5, 15.8		
4)	12, -7, 12, -7, -7		
5)	-0.5, 0.4, 0.4, 0.4		

Do outliers have an effect on the mode? Explain why or why not.

Part 2

Calculate the median using the outlier(s) and without the outlier(s)

	Data Set	Median With Outlier(s)	Median Without Outlier(s)
1)	15, 13, 19, 14, 17, 19, 47		
2)	108, 105, 108, 106, 107, 109		
3)	24.3, -8.2, 25.7, 24.6, 27.2, 26.1		
4)	-14, -19, -17, -22, 21, -24		
5)	-1.3, 0.1, 0.6, -0.5, 13.8, -1.2		

Do outliers have an effect on the median? Explain why or why not.

Mean, Median, Mode – Outliers Word Problem

Questions

Answer the questions below



Alex loves golf. He has kept track of his last 10 shots for 4 different clubs. He wrote down the distance in yards he hit each of the clubs in the table below.

	1	2	3	4	5	6	7	8	9	10
Pitching	132	143	137	24	134	136	132	130	133	132
7 Iron	161	161	237	168	163	164	168	164	158	153
3 Iron	194	193	198	199	209	42	201	198	198	198
Driver	313	315	307	322	299	303	314	52	311	311

- a) Calculate the mean distance for each club Alex used?

	Pitching Wedge	7 Iron	3 Iron	Driver
Mean				

- b) Calculate the median distance for each club.

	Pitching Wedge	7 Iron	3 Iron	Driver
Median				

- c) Calculate the mode of each club.

	Pitching Wedge	7 Iron	3 Iron	Driver
Mode				

- d) Look for some outliers in the data. What could have caused these outliers?

- e) To calculate the average distance of all four clubs combined, find the mean of the medians for each club.

Relationship Between Variables

A scatter plot is a graph in which the values of two variables are plotted along the x and y axis. Using a scatter plot allows us to quickly see what type of relationship there is between the two variables.



Weak Negative Relationship



Weak Positive Relationship



Strong Negative Relationship



Strong Positive Relationship

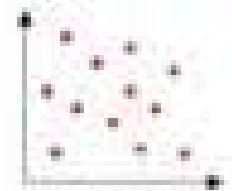

No Relationship

Practice

Identify the relationship between the variables



1)

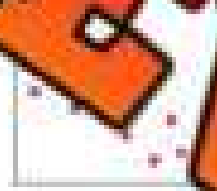

2)

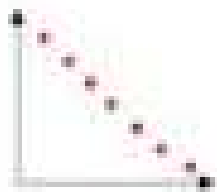

5)

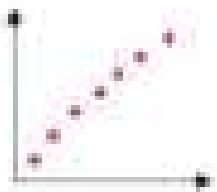

6)

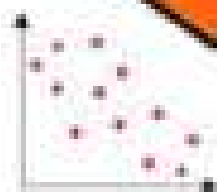

7)

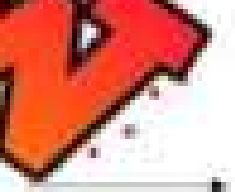

8)



9)

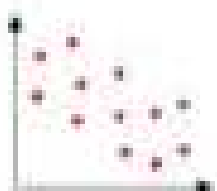

10)



11)



12)

Scatter Plot – Relationship Between Variables

Practice

Plot the points on the scatterplot and answer the questions

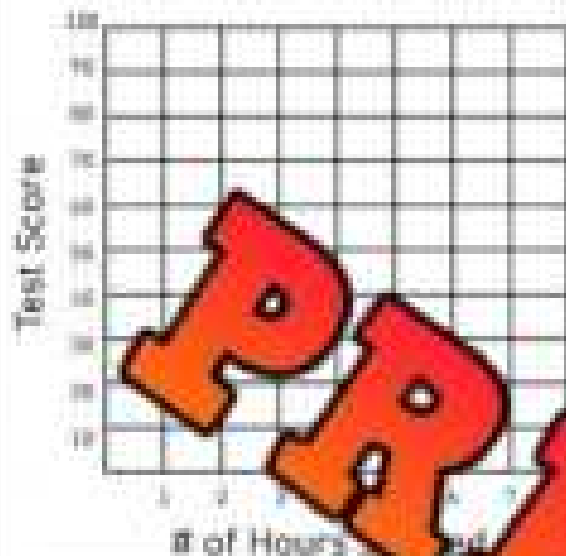

# of Hours Studied	Test Scores
6	90
2	55
1	45
2	70
4	75
7	95
5	80

1) What is the relationship between the variables?

2) Are you surprised about the relationship between the variables? Explain.

3) Could you have predicted the relationship between these variables without graphing the data? Explain.

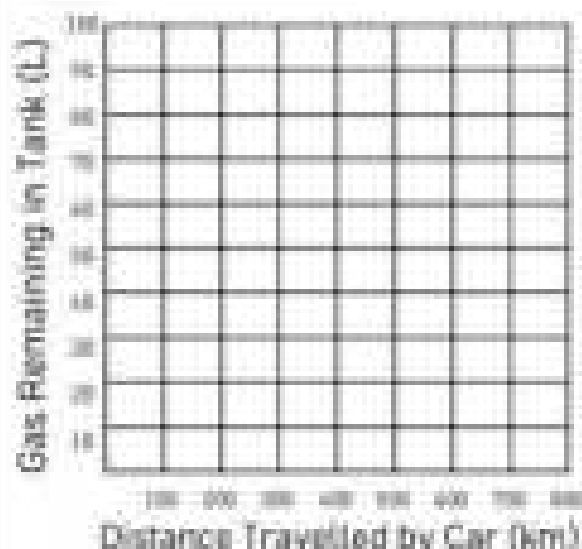

Distance (km)	Time (h)
100	70
200	58
300	45
400	31
500	20
600	10
700	0

1) What is the relationship between the variables?

2) Are you surprised about the relationship between the variables? Explain.

3) Could you have predicted the relationship between these variables without graphing the data? Explain.

Practice

Plot the points on the scatterplot and answer the questions.

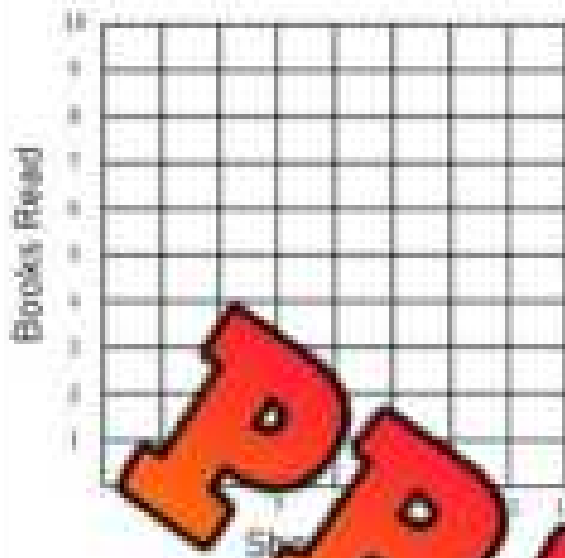

Shoe Size	Books Read
5	4
6	6
8	4
7	2
10	7
6	10
11	3

1) What is the relationship between the variables?

2) Are you surprised about the relationship between the variables? Explain.

3) We've learned that shoe size doesn't affect how many books someone reads. Write another example of two variables that have no relationship.

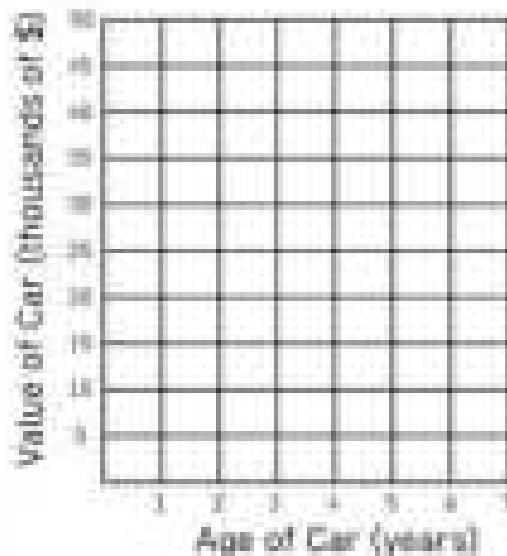

Age	Value
4	35
6	10
7	15
1	55
3	45
6	40
5	20

1) What is the relationship between the variables?

2) Are you surprised about the relationship between the variables? Explain.

3) Write another example of two variables that would likely have a similar relationship.



Explaining Relationship Between Variables

Explain

Describe what type of relationship the variables would have. Explain.

	Variable 1 (x-axis)	Variable 2 (y-axis)	Relationship
1	Hours worked	Money earned	
Explain	_____		

	Variable 1 (x-axis)	Variable 2 (y-axis)	Relationship
2	Hours of study	Test scores	
Explain	_____		

	Variable 1 (x-axis)	Variable 2 (y-axis)	Relationship
3	Number of car payments made	Amount owed on car loan	
Explain	_____		

	Variable 1 (x-axis)	Variable 2 (y-axis)	Relationship
4	Number of people in a family	Temperature the family keeps their house	
Explain	_____		

	Variable 1 (x-axis)	Variable 2 (y-axis)	Relationship
5	Minutes of exercise	Calories burned	
Explain	_____		

Explaining Relationship Between Variables

Explain

Describe what type of relationship the variables would have. Explain.

	Variable 1 (x-axis)	Variable 2 (y-axis)	Relationship
1	Time it takes to get to school (minutes)	Distance (metres) a student lives from school	

Explain

	Variable 1 (x-axis)	Variable 2 (y-axis)	Relationship
2	Hours spent in class	Number of absences in a class	

Explain

	Variable 1 (x-axis)	Variable 2 (y-axis)	Relationship
3	Time the water is being heated (minutes)	Temperature of the water	

Explain

	Variable 1 (x-axis)	Variable 2 (y-axis)	Relationship
4	Students' height	Students' grades	

Explain

	Variable 1 (x-axis)	Variable 2 (y-axis)	Relationship
5	Time spent practicing free throw shooting	Number of free throws missed each game	

Explain

PREVIEW

Relationship Between Variables - Outliers

When determining the relationship between variables, it is possible that the data has an outlier. An outlier could mean that something went wrong with the data collection, or it may be a valid, unexpected piece of the population that needs further clarification. In many cases, the outlier can be removed so that we can determine the relationship between the variables more accurately.

Outlier - Someone who didn't study but did very well



Outlier - Someone who studied a lot but did poorly



Practice

Use the data to describe the relationship.

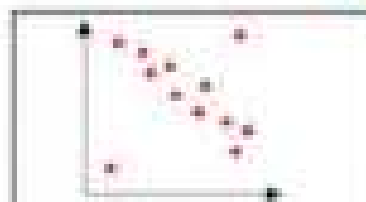

1)

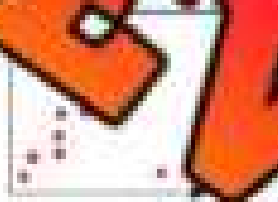

2)



5)



6)

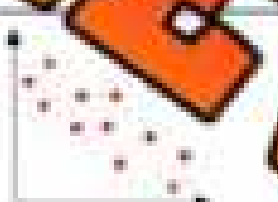

7)



8)

Height and Weight of Babies

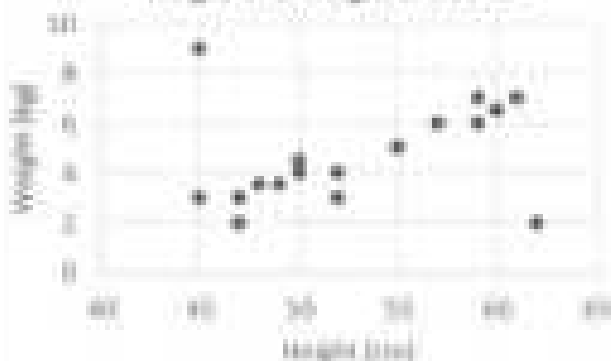

1) Which values are outliers?

2) What is the relationship between the variables?

3) What caused these outliers?

Relationship Between Variables - Outliers

Practice

Answer the questions about the scatter plot

1) Golf - Distance Hit By Driver by Age



1) Which values are outliers?

2) What is the relationship between the variables?

3) What caused these outliers?

1) Which value

2) What is the relationship between the variables?

3) What could have caused the outlier?

2) Video Game Sales



1) Which value

2) What is the relationship between the variables?

3) What caused these outliers?

3) Income vs Years of Post-Secondary Education



1) Which values are outliers?

2) What is the relationship between the variables?

3) What caused these outliers?

4) House Size vs Value

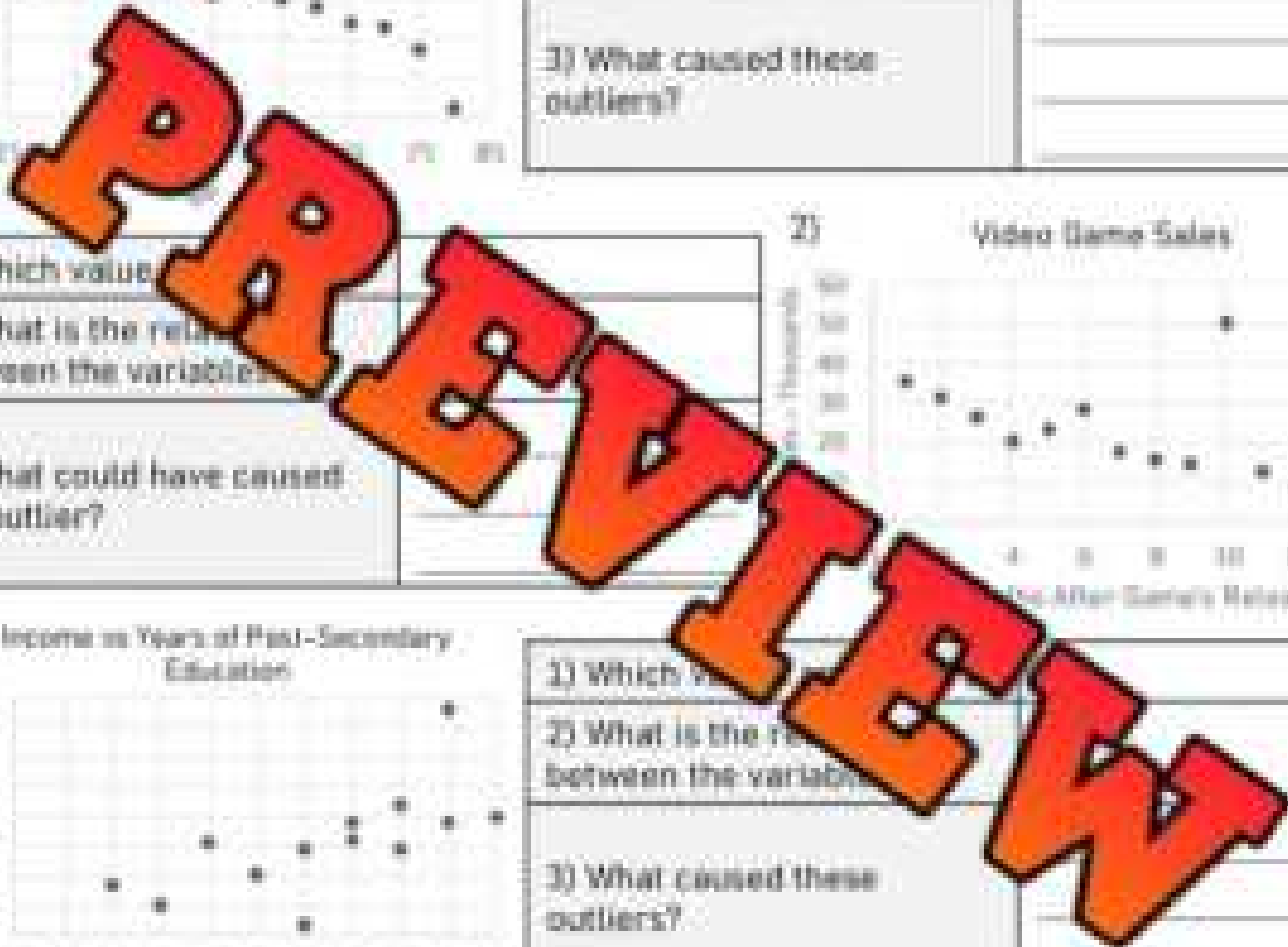
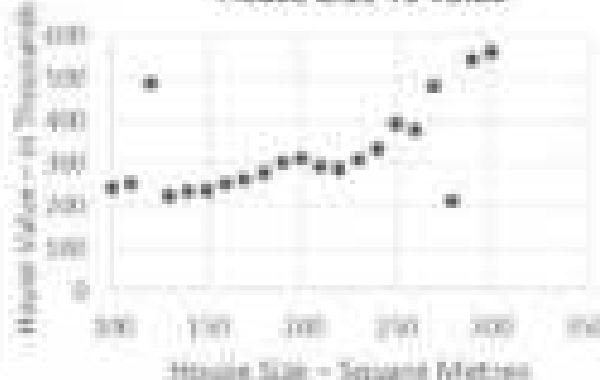

Line of Best Fit

A line of best fit can be drawn through the majority of the points on a scatter plot. It can be used to make predictions if the relationship between the 2 variables is strong.

Basketball Ticket Prices

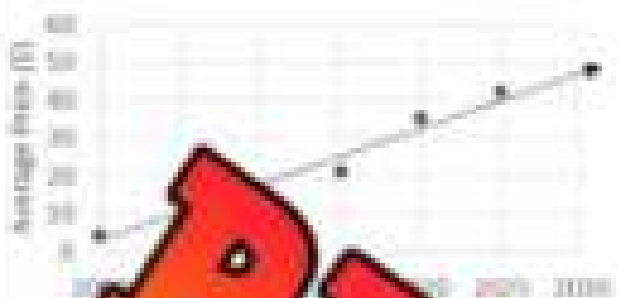

When drawing a line of best fit, we can try to use the following criteria:

- Draw the line in the middle of the data
- Have equal points on both sides of the line
- Points are an equal distance from the line

Remember - drawing a line of best fit is not an exact science. We should try to meet the criteria above, but it will not always be possible. The more you follow the criteria, the better your line of best fit will be.

A good line of best fit will allow us to make predictions about the data. The line of best fit in the example above shows that the average price for tickets in 2030 will be around \$47.

Practice

Draw a line of best fit and use it to make a prediction.

Mountain Temperatures



Earnings Made At Work



1) What will the temperature be at 4000m?

2) How much will you earn in 10 hours?

Height versus Arm Span



Draining Hot Tub

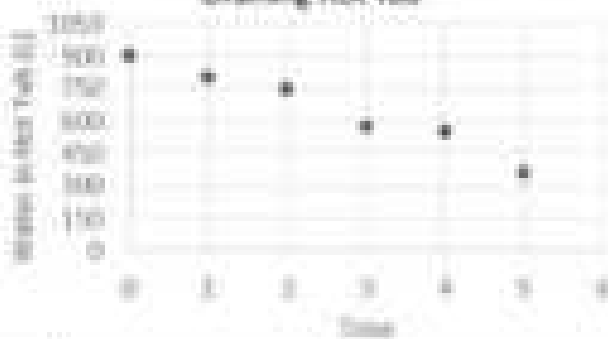

3) What height would someone be with 170cm arm span?

4) How much water will be in the tub after 6 hours?

Interpreting Scatter Plot – DVD/Blu-Ray Sales

The sales from 2010 to 2022 of blue-ray and DVD's are presented in the scatter plot below.

Practice

Answer the questions below



DVD and Blu-Ray Sales From 2010-2022

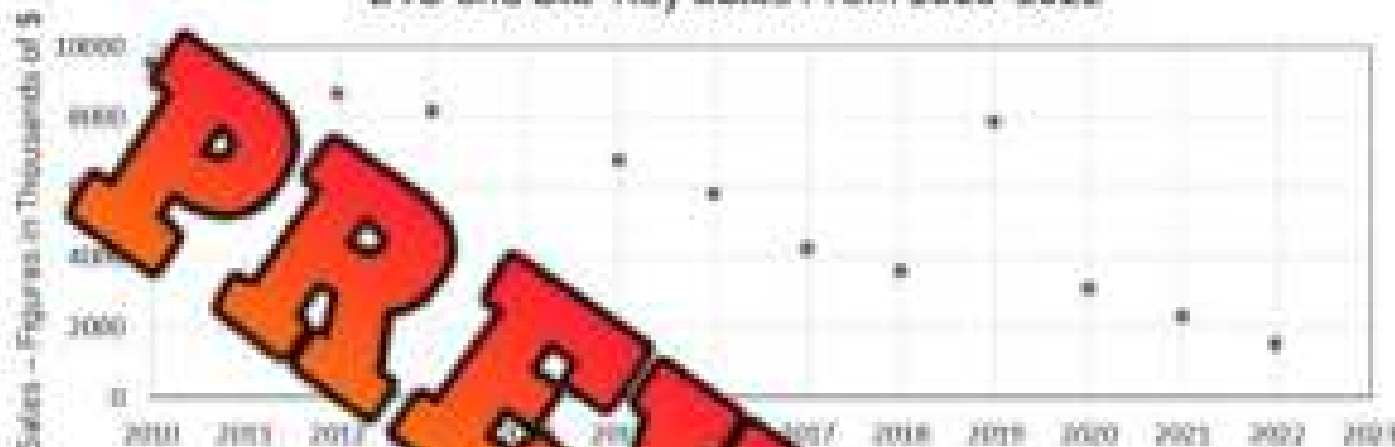

- 1) What are the outliers in the data?
- 2) What could explain the outliers?
- 3) What is the relationship between the two variables? Is it strong/weak, positive/negative?
- 4) Which years were the top 5 in sales?
- 5) Draw a line of best fit. How many sales do you think there will be in 2023?
- 6) How many sales were made in 2022? How many dollars were sold?

Creating a Scatter Plot – Gold Rush Population

Directions

Display the data below in a scatter-plot.



The population in Dawson City fluctuated a lot due to the gold rush. The population has been displayed in the table below. Represent the data in a scatter-plot.

Year	1894	1895	1896	1897	1898	1899	1900
Population (in thousands)	1	1	30	35	40	8	6

PREVIEW

Interpreting The Data

Provide at least 3 conclusions you can draw from the graph.

Creating a Scatter Plot – Lemonade Sales

Directions

Display the data below in a scatter-plot

Zackary sells lemonade at the end of his driveway. He tracked his sales for the last 17 days and he also tracked the temperature as he wanted to learn more about his business. Represent his data on the scatter-plot below.



Temperature °C	# of Sales
24	4
20	3
28	16
25	12
27	17
29	4
29	20
30	18
21	2
26	12
24	10
28	16
25	13
	4
	2
	19
	18



Interpreting The Data

Answer the questions below

1) What two outliers did you notice?	
2) What could have caused the outliers?	
3) Draw a line of best fit. How many sales would you expect on a day that is 31°C?	

Collecting Primary Data – Scatter Plot

Brainstorm

Display the data below in a scatter-plot

Areas of Interest(basketball, video games,
music, etc.)**Research Question**

Circle the graph you would use to represent the data

Research

(Ex. How many hours do you spend on your screen time daily and how many hours do you exercise daily?)

Hypothesis

Do you expect a positive or negative relationship between these variables? Explain the type and why

Example

I expect a strong negative relationship because the more screen time someone has the less time they have to exercise.

Draw a table that will help you collect and organize your data.

Name: _____

Creating a Scatter Plot

Use the data you collected to plot your graph. Remember the following labels:

X axis label Y axis label Title Scale Value for y-axis



Vertical Bar Graph – Immigration

Canada is a popular place for people from other countries to move to. The number of immigrants who moved to Canadian provinces is represented in the bar graph. Fill in the frequency table below.

Province	Frequency
AB	
BC	
MB	
NS	
ON	
PEI	
QUE	
SK	
Mean of Canada	
Mode of Canada	
Median of Canada	

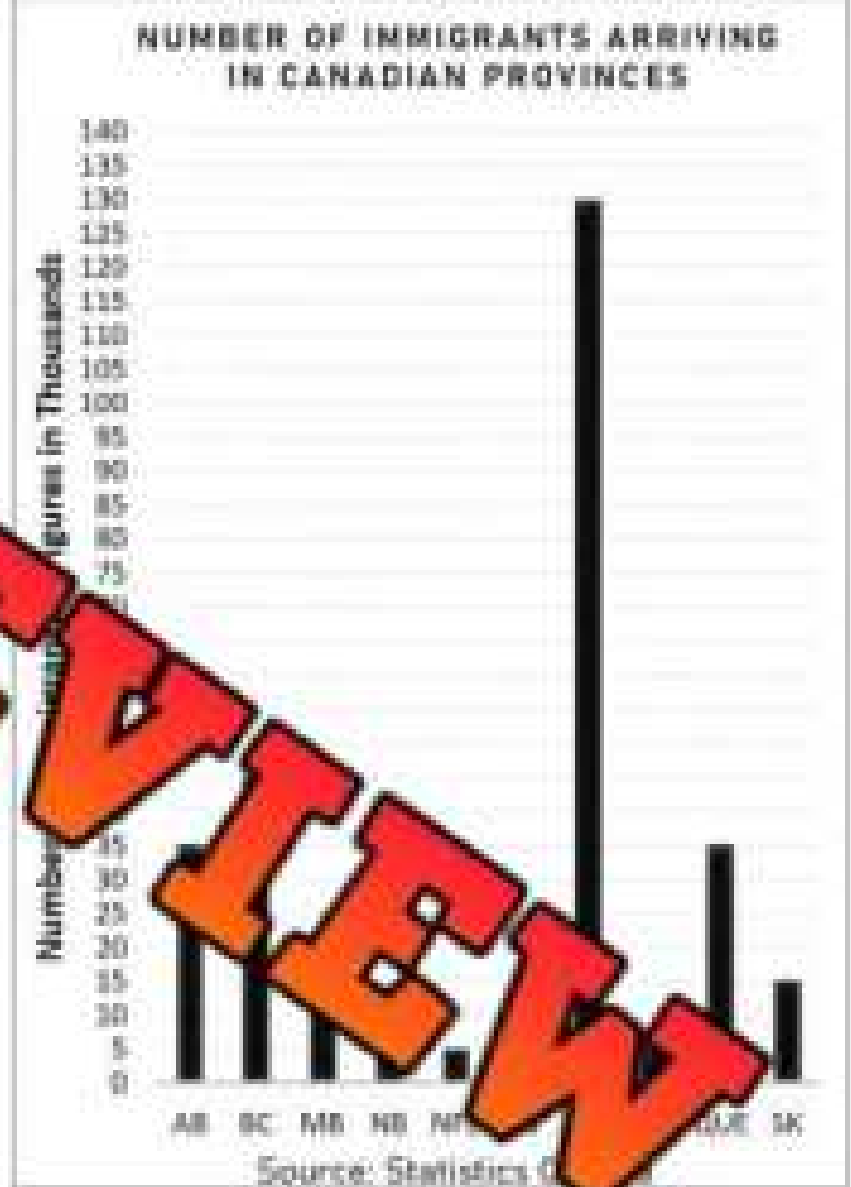

- How many more immigrants moved to Ontario than New Brunswick?
- Did more immigrants move to Ontario than all the other provinces combined?
- Is the data quantitative or qualitative?
- Was the data collected from a primary or secondary source?
- In your opinion, what is one reason why more people immigrate to Ontario?

Activity Title: Flip the Data**Objective**

What are we learning about?

Students will engage in a fun and active game where they read data from a bar graph and answer questions to earn the opportunity to flip a bottle or cup. This activity combines data interpretation skills with a physical challenge, adding excitement and a competitive element to learning.

Materials

What you will need for the activity.

- Bottle or cup (to flip)
- A smartboard (to display bar graphs)
- Timer (stopwatch or timer app)
- Question cards (with questions on the data)
- Scoreboard to keep track of results

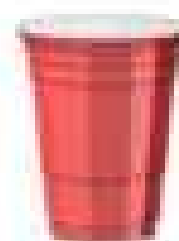
**Instructions**

How you will complete

1. Divide the class into small teams, ideally of 5 students each.
2. Prepare a series of bar graphs to display data and corresponding question cards that ask about the data.
3. One team at a time comes to the front where the graph is displayed.
4. Display the first bar graph on the smartboard.
5. The first student from the active team reads the graph and selects a question card. Start the timer when the question is first shown.
6. The student answers the question based on the data presented in the graph. The teacher checks the answer.
7. If the student answers correctly, they flip their bottle or cup repeatedly until they land it upright. When they do, the next teammate can take their turn.
8. If the student's answer is incorrect, they must try another question card before they can attempt to flip.
9. The team's turn ends either when all members have successfully flipped their bottle/cup or when the timer reaches a set limit (e.g., 3 minutes).
10. Record the team's time or number of successful flips on the scoreboard.
11. Repeat steps 4-10 for each team. The team with the fastest time wins.

Graph 1

What did you learn from the graph?



Graph 3

What did you learn from the graph?



Graph 6

What did you learn from the graph?



PRE-EVALUW

Graph 7

What did you learn from the graph?

Recycling Rates of Different Materials in Two Cities Over a Year



Questions

Choose a question to ask the student who is about to flip their bottle

What is the title of the graph?

What is the title of the Y-axis?

What is the title of the X-axis?

What does each bar on the graph represent?

Which category shows the highest values for both bars?

Which category shows the lowest values for both bars?

How many categories are displayed on the graph?

What is the range of values on the Y-axis?

What is the total number of _____ represented by all bars?

What is the difference between the highest and lowest categories for both bars?

Are there any categories that have _____ which ones?

How does the value of one specific category compare to _____ bars?

What could be a possible reason for the highest value?

What could be a possible reason for the lowest value?

What trends can you observe from the graph?

How might this data be useful?

If you could add another category to this graph, what would it be?

How would you describe the overall distribution of data?

What insights or conclusions can you draw from this graph?

How might the information on the graph impact decisions or opinions?

What are the 2 sets of data representing?

Name one surprising fact from this data

What scale was used in this graph?

What is a different scale that you could use in this graph?

Multiple-Bar Graph – Favourite Social Media

The students in grade 6, 7, and 8s were asked which social media app was their favourite. The results have been sorted by grade in the multiple-bar graph below.

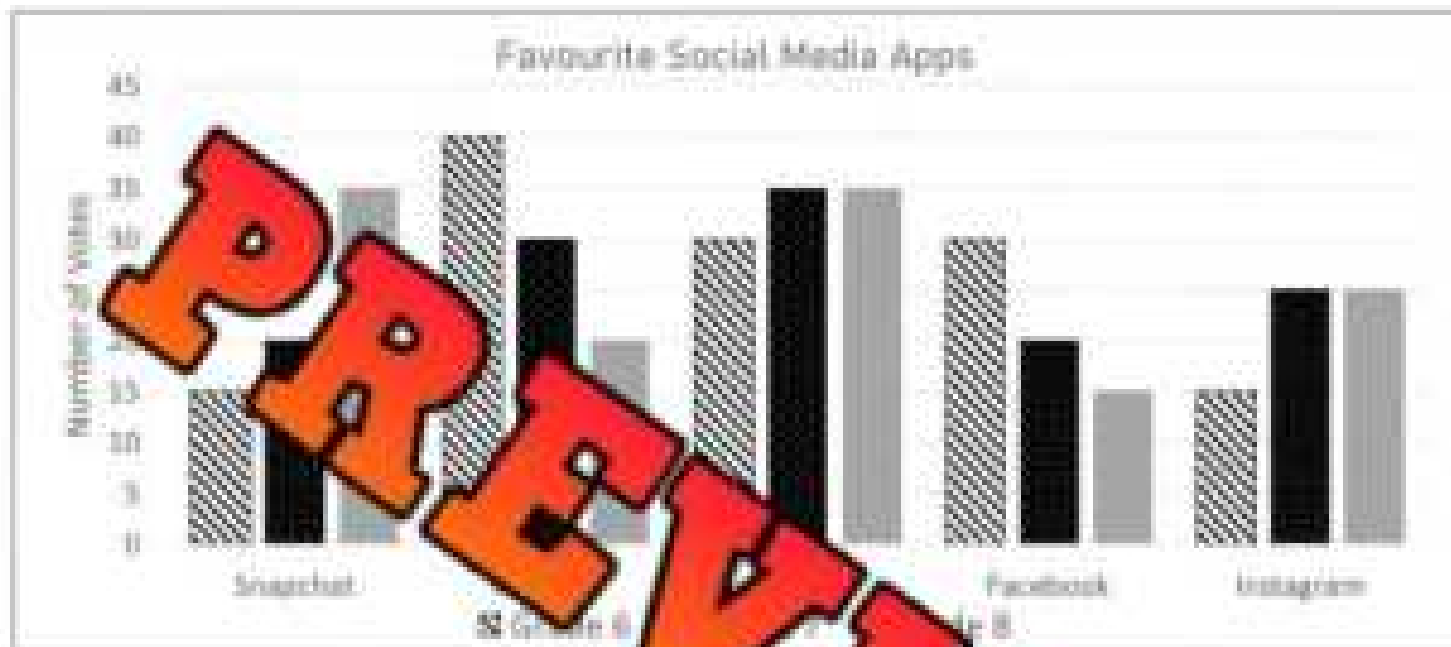

Part 1

Fill in the frequency table by reading the multiple-bar graph above.

	6		7		8s	
	#	%	#	%	#	%
Snapchat	15/130	12				
YouTube						
Tik Tok						
Facebook	30/130	23				
Instagram						
Total	/130					

Part 2

Answer the questions below.

a) How many students in each grade were surveyed?

b) Which social media was the most popular? How many votes did it get?

Interpreting a Broken-Line Graph

Children are using screens younger and younger. The multiple-line graph represents the percentage of children who either use a tablet or computer in the classroom or own a cell phone.

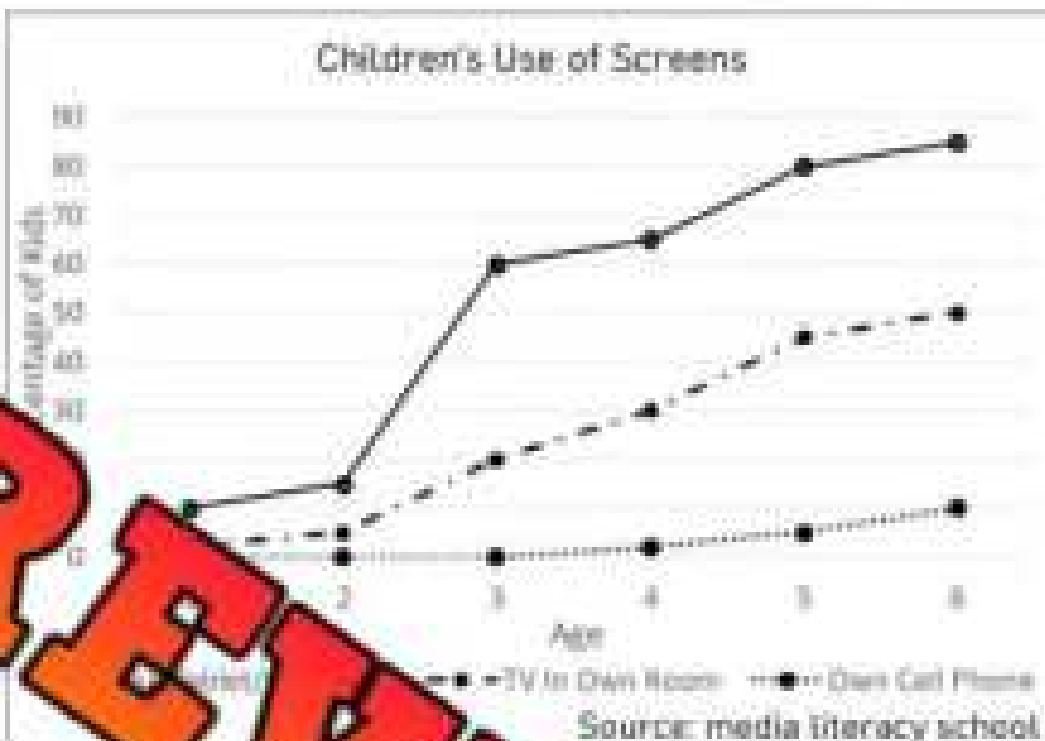

Questions

Answer the questions below.

- 1) What percentage of 5-year-olds use a tablet/computer in the classroom?
- 2) What percentage of 6-year-olds own a cell phone?
- 3) Is there a relationship between the two variables – age and percentage of kids using screens?

- 4) At what age do most children start using a tablet/computer? Why do you think that is?

- 5) What do you think about this data? Is it good that children are using screens? Explain.

Exit Cards

Cut Out Cut out the exit cards below and have students complete them at the end of class.

Name: _____

The graph represents how many students in a school like each of the Canadian basketball teams (Toronto Raptors, Vancouver Bandits, and Edmonton Stingers) as their favourite team. The data is collected over a 4-year period from 2019 to 2022.

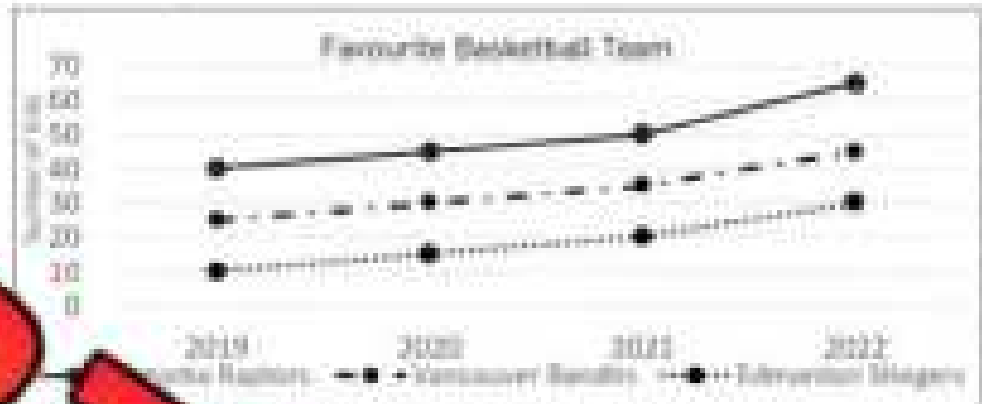

- How many students listed the Toronto Raptors as their favourite team in 2022?
- How much did the popularity of the Vancouver Bandits increase between 2019 and 2022?
- What is the trend for the Edmonton Stingers' popularity over the 4-year period?
- What conclusions can you draw about how popular basketball is in Canada?

Name: _____

The graph represents how many students in a school like each of the Canadian basketball teams (Toronto Raptors, Vancouver Bandits, and Edmonton Stingers) as their favourite team. The data is collected over a 4-year period from 2019 to 2022.



- How many students listed the Toronto Raptors as their favourite team in 2022?
- How much did the popularity of the Vancouver Bandits increase between 2019 and 2022?
- What is the trend for the Edmonton Stingers' popularity over the 4-year period?
- What conclusions can you draw about how popular basketball is in Canada?

Interpreting a Histogram

The science teacher posted a histogram of the results of the last test.

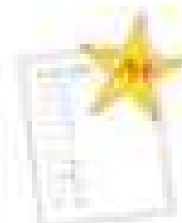
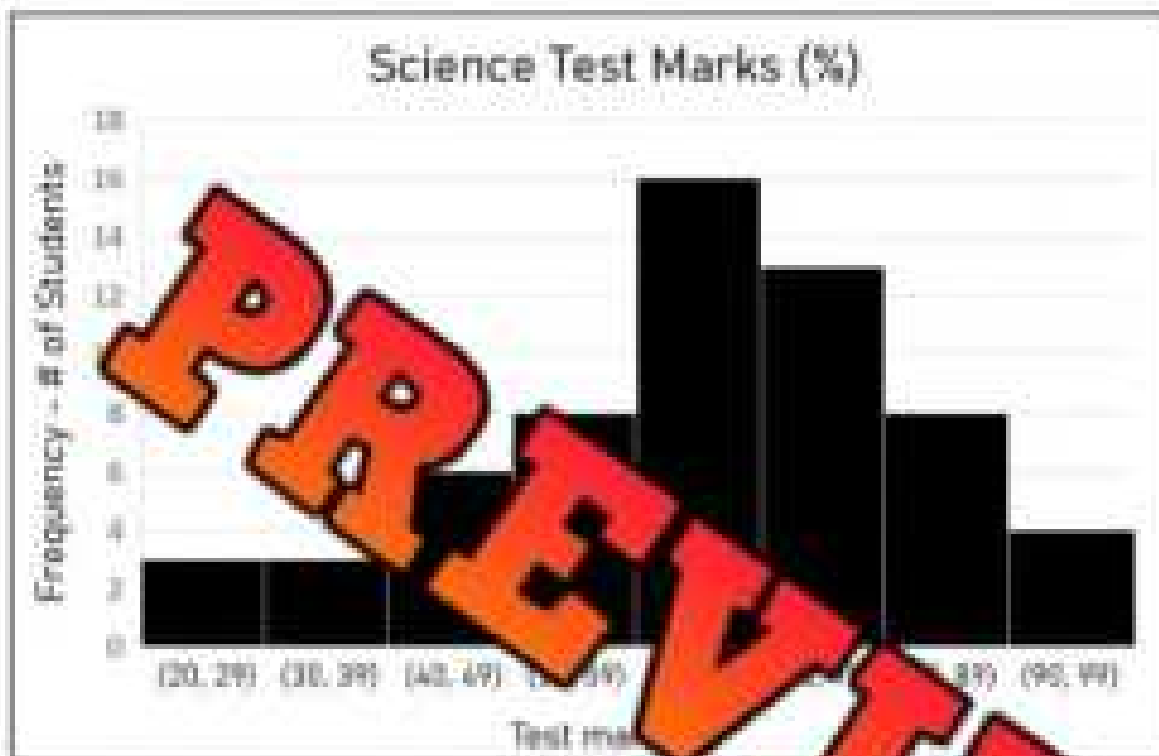

Questions

Fill in the tables below.

Frequency Table	
0-9	
10-19	
20-29	
30-39	
40-49	
50-59	
60-69	
70-79	
80-89	
90-99	

a) Which test score was most frequent?	
b) Did most people pass or fail?	
c) How many students failed the test (below 50%)?	
d) How big are the intervals? What range of marks do they include?	
e) How many students took the test?	
f) How many students got an A (80%+)?	
g) Based on the results, do you think the test was easy, hard, or fair? Explain your thinking.	

Creating a Histogram

A **histogram** is used to display the frequency of numerical data. We can use a histogram to display continuous or discrete data, but only with quantitative data. If the data is qualitative, we would use a bar graph instead.

Directions

Display the data below in a histogram

A restaurateur wanted to know what age groups used his restaurant. The most popular age group was 18-24. He asked 30 customers their age. His data is presented below. Represent the data in a histogram.

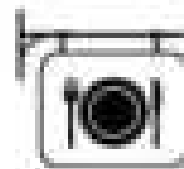

15	18	21	25	28	33	33	55	57
62	21	24	27	0	30	46	41	58
68	61	72	71	41	8	42	53	66

Collecting Data - Histogram

Data Collection

Collect primary or secondary data and represent it in a histogram.

Question of Interest _____

Use the box below to organize your data.

Interpreting The Data

Answer Yes or No

- 1) Was your data collected from a primary or secondary source?
- 2) Why did you choose to learn more about this topic?

3) What conclusions can you draw from your data? What did you learn?

4) What further research should be done in relation to the topic you chose?

Creating a Histogram

Use the data you collected to plot your graph. Remember the following labels:

X axis label Y axis label Title Scale Intervals/Bins



Circle Graph - Budget

Sofia is heading to college soon. She has \$1000 to spend in total on the things she needs. She created a circle graph to better understand where her money is going.



Part 1

Fill in the frequency table reading Sofia's graph

	Rent	Food	Clothing	Books	Cell Phone	Entertainment
%						
\$ Spent						

Part 2

Answer the questions below

- 1) What will Sofia spend most of her money on?
- 2) Which two expenses will account for 70% of her money?
- 3) How much money will she spend on everything except rent?
- 4) What percentage do all 6 expenses add up to?
- 5) What are your thoughts on her budget? How might your budget be the same or different?

Exit Cards

Cut Out Cut out the exit cards below and have students complete them at the end of class

Name: _____

Alex is planning a vacation. He has \$1500 to spend in total on various activities and needs. He created a circle graph to better understand how he will allocate his money.

Alex's Vacation Budget



1) What will Alex spend most of his money on?	
2) Which two categories together account for 65% of his vacation budget?	
3) How much money will Alex spend on food and entertainment combined?	
4) What percentage do all 5 categories add up to?	

Name: _____

Alex is planning a vacation. He has \$1500 to spend in total on various activities and needs. He created a circle graph to better understand how he will allocate his money.

Alex's Vacation Budget

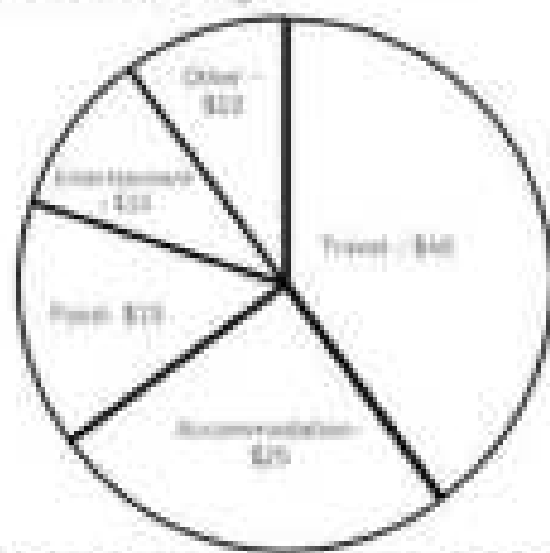

1) What will Alex spend most of his money on?	
2) Which two categories together account for 65% of his vacation budget?	
3) How much money will Alex spend on food and entertainment combined?	
4) What percentage do all 5 categories add up to?	

Circle Graph – Population Distribution

The population of each province and territory in Canada has been displayed in the circle graph.

Population Distribution in Canada

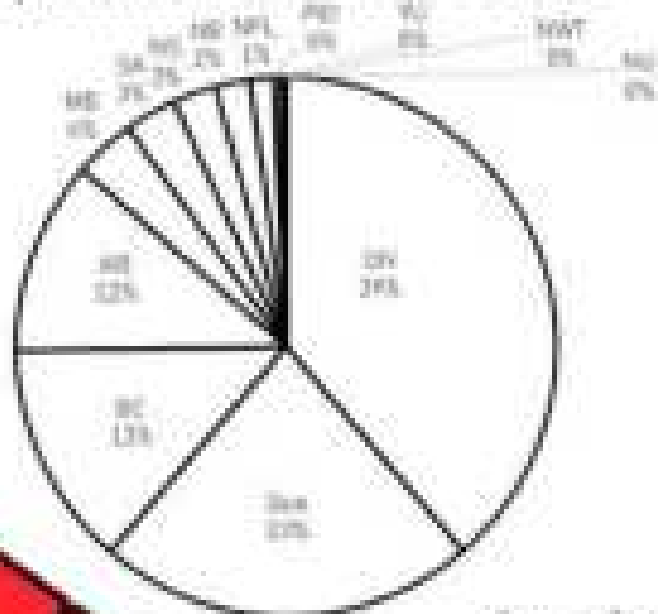

Source: StatCan

PREVIEW

Part 1

Fill in the frequency table by using the circle graph

Province	AB	BC	MB	NB	NFL	NS	PEI	SK	NWT	YU	NU
Population Distribution %											

Part 2

Answer the questions below

- 1) What percentage of Canadians live in Ontario and Quebec?
 - 2) Do half of Canadians live in Ontario and Alberta?
 - 3) Do half of Canadians live in Alberta, BC, and Quebec?
 - 4) Martin thinks that more than 4 of 5 Canadians live in 4 provinces in Canada. Is he correct? Explain.
-
-
-
- 5) Why do you think not many Canadians live in the territories? Explain.
-
-
-

Drawing a Circle Graph – Global Emissions

According to the World Resources Institute, Canada accounts for approximately 2% of global greenhouse emissions. The emissions each country produces are listed in the table below.



Part 1 Fill in the table below to determine the angle measurements for the circle graph.

	Relative Frequency (as a percentage)	Fraction	Decimal	Angle Measure
China	30	30/100	0.30	$0.30 \times 360 = 108^\circ$
USA	15	15/100	0.15	$0.15 \times 360 = 54^\circ$
Europe				
Russia	5			
India				
Japan				
Brazil	2			
Canada	2			
Others	29			

Part 2 Use a protractor to draw the angles for the circle graph.

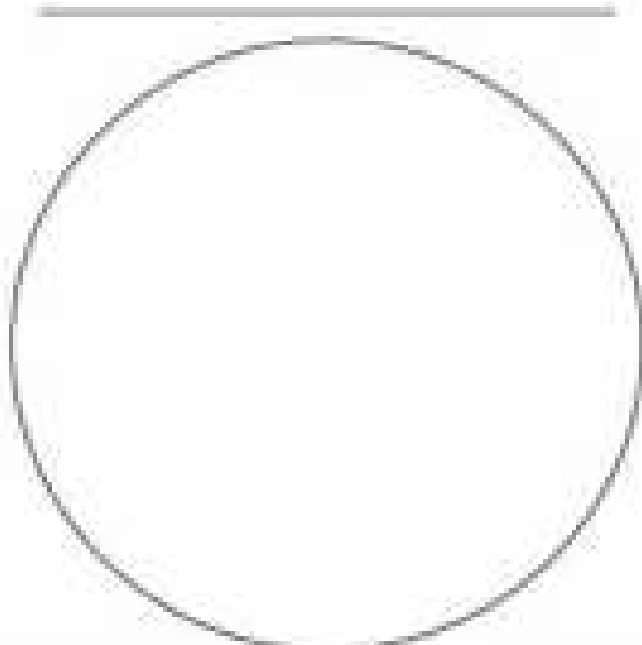

1) How many times does China produce emissions?

2) Why do graphs sometimes have an 'other' category?

3) Why do you think China produces so many emissions?

Name: _____

Creating a Circle Graph

Use the data you collected to plot your graph. Remember the following labels:

Title

Labels for each section

Percentages/totals



CANADA'S POPULATION | JULY 1, 2020



Canada's population reached the 38 million mark between April 1 and July 1, 2020. However, the annual increase of 411,854 was the lowest since 2015/2016 due to international migration being slowed by COVID-19.

Population growth 2019/2020



Canada recorded its lowest natural population growth since 1967

This was expected because of the overall aging of the population, as well as the impact of the COVID-19 pandemic, with more deaths than births.

International migration

While Canada has welcomed record numbers of permanent and temporary immigrants since 2017/2018, international migratory growth decreased sharply from April 1 to June 30, 2020, following the border restrictions introduced as a result of the pandemic.



Creating an Infographics

Directions: Display the data set in different ways. Write in the boxes and draw pictures.

Students in high school often have jobs outside of school. A study was done to determine if having a job led to better or worse grades. The number of hours a student worked, and their grades are represented in the table below.

Hours Worked (per week)	3	2	1	4	3	6	7	5	6	4	5	6
Avg. Grade	70	85	80	70	80	95	85	95	75	80	90	



Misleading Graphs

A supplement company that sells muscle-growth pills wants to share data they collected about the results of their pills. The users of their pills have gained muscle, which is what they want to show off. Their marketing team created 2 graphs. Which graph should they choose?

Muscle Growth – Graph A



Muscle Growth – Graph B



Questions

What do you notice about the 2 graphs?



a) Which graph would you use to show customers that your muscle-growth pills work really fast?

b) How are the graphs different? Do they have the same data?

c) How much muscle was gained in the 5 months?

d) Does graph B make it seem like the users gained muscle quicker? Explain how they made it look this way.

e) Why is it important to read a graph carefully?

Misleading Graph – Bar Graph

Best Bank is advertising their low interest rate compared to 3 other bank's interest rates. They want to show their rate is by far the lowest. Which graph should they use?

Bank's Low Interest Rate – Graph A



Bank's Low Interest Rate – Graph B

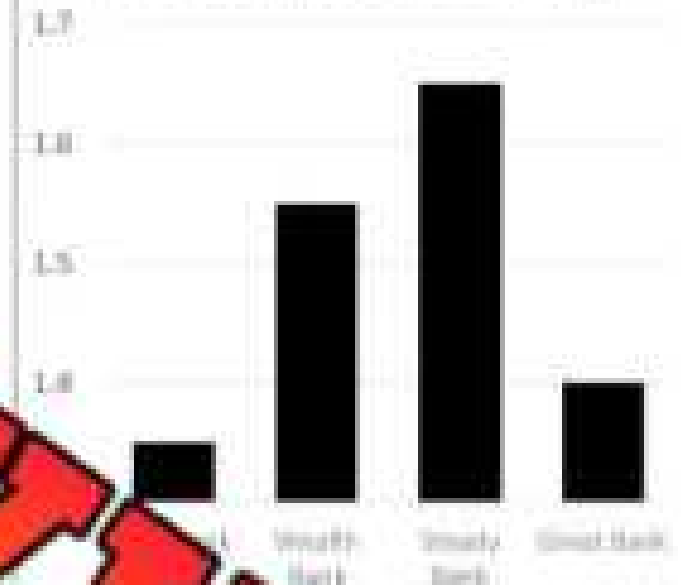

Questions

What do you notice about the two graphs?

a) How are the graphs different? Do they have the same scale?

b) Which graph would you use if you were Best Bank? Explain.

c) Why would advertisers use misleading charts like this to sell their products?

Misleading Graph – Multiple-Bar Graph

Terrific TVs sells televisions. Their biggest competition is a company named, Special TVs. Terrific TVs completed a study that compared the two brands. The results are below.

Best TV – Customer Votes – Graph A

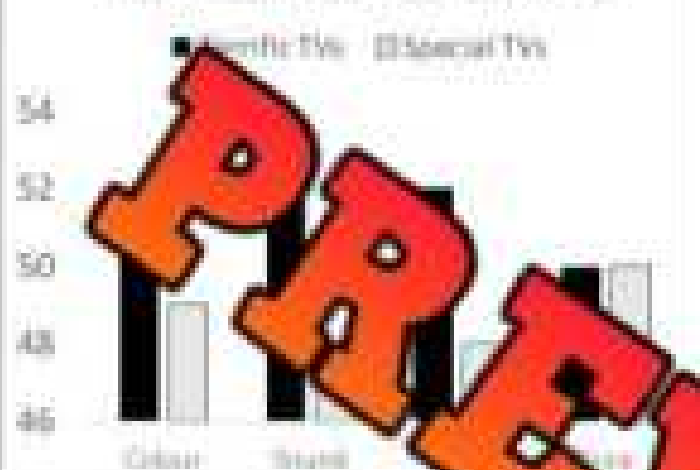

Best TV – Customer Votes – Graph B

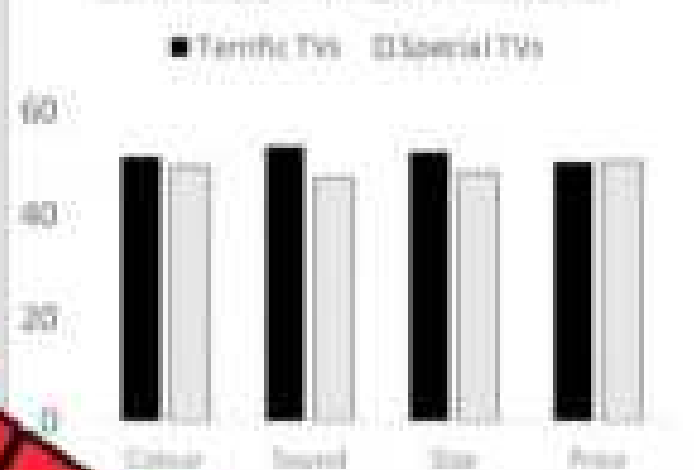

Questions

What do you notice about the two graphs?

a) Which graph would you use if you were Terrific TVs?

b) How many more votes in total did Terrific TVs get over Special TVs?

c) Is Terrific TVs a lot better than Special TVs? Explain.

d) Do you think it is fair that businesses create misleading graphs like this one? Explain.

Misleading Graph – Circle Graph

A Science and Technology school is trying to advertise that Science is a popular subject for students. A study that surveyed 100 students asking their favourite subject was completed. The results have been displayed in 2 graphs below.

Graph A - Most Popular Subjects

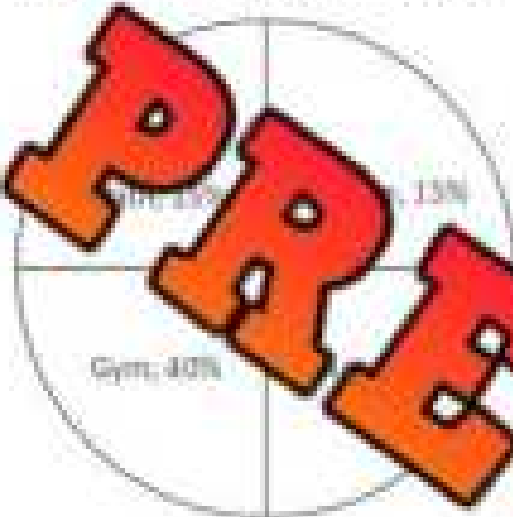

Graph B - Most Popular Subjects



Questions

What do you notice about the two graphs?

a) Which of the two graphs is misleading? Explain why.

b) Which graph would you use if you were the science and technology school? Explain.

c) Do you think people would fall for this misleading graph? Explain your opinion.

Exit Cards

Cut Out Cut out the exit cards below and have students complete them at the end of class.

Name: _____

A tech company conducted a survey to find out which social media platforms were the most popular. They asked 200 teenagers, aged 13-17. The results are displayed below:

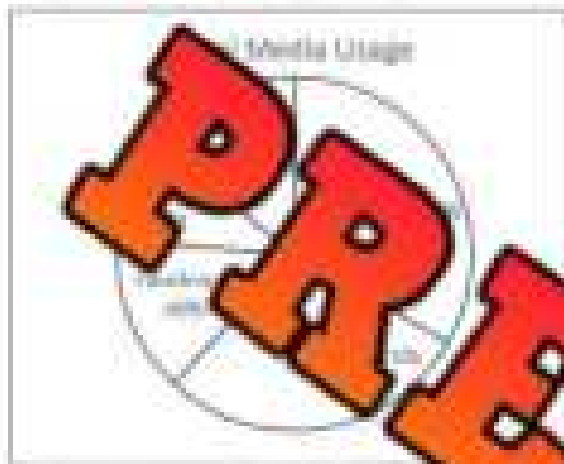

a) Why is this circle graph misleading?

b) Why is it important to look at the group being surveyed (teenagers) before trusting the data?

c) Can you trust all data? What are some ways companies can create misleading data through surveys?

Name: _____

A tech company conducted a survey to find out which social media platforms were the most popular. They asked 200 teenagers, aged 13-17. The results are displayed below:

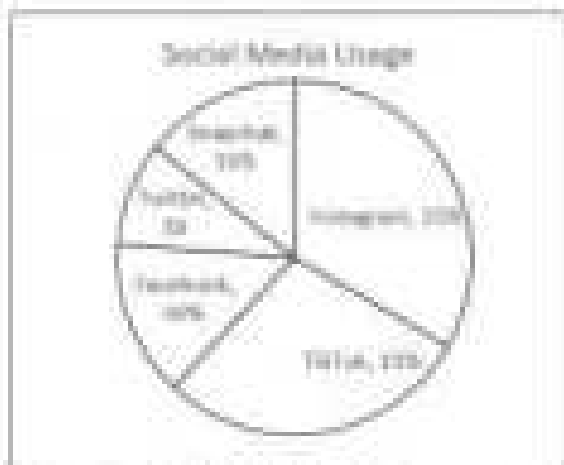

a) Why is this circle graph misleading?





b) Why is it important to look at the group being surveyed (teenagers) before trusting the data?

c) Can you trust all data? What are some ways companies can create misleading data through surveys?

Misleading Pictograph – Company Earnings

Newco Software Company has been operating for the last 5 years. Their earnings each year have been represented in the pictograph below.

Newco's Earnings – Last 5 Years

			
Year 1	Year 3	Year 4	Year 5
\$15 405	\$42 123	\$64 851	\$81 235

Questions

What do you notice about the pictograph above?

a) How much more earnings did Newco make in Year 5 than Year 1?

b) What do you notice or wonder about the graph? List 2 things.

c) Why is the graph misleading? Hint: look at the size difference between Year 1 and Year 5. Remember your understanding of volume.

d) Approximately how many times larger is the Year 5 cube than the Year 1 cube?

Misleading Graphs

Wellington High School is proud of how many students they have on their honour roll (80% or more). They want to show off their success by posting their data.

Graph A - Honour Roll

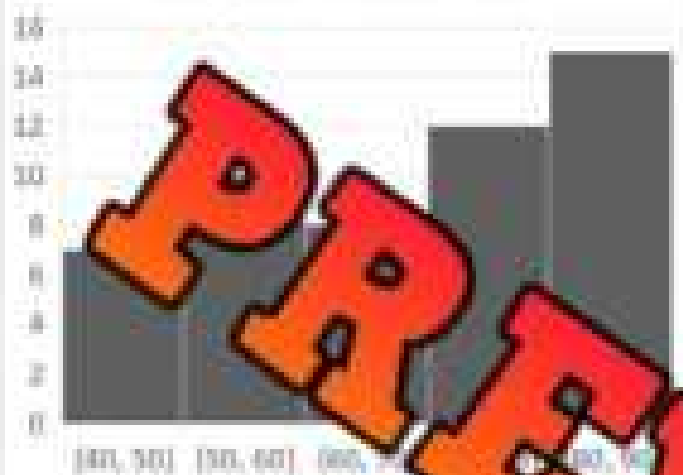

Graph B - Honour Roll

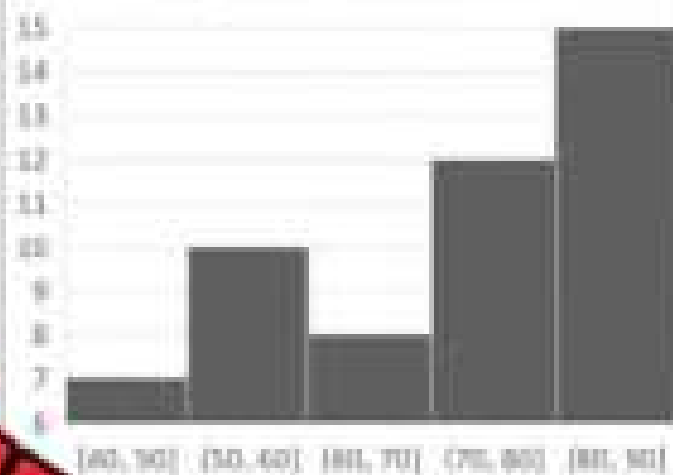

Questions

What do you notice about the two graphs?

a) Which histogram should Wellington High School use to emphasize their success?

b) How many more students were on the honour roll? _____

c) How many did not make the honour roll? _____

d) Would it be fair to use Graph B? Why or why not?

e) Make a connection – Have you ever seen an advertisement use a misleading graph?

Truth or Lie? Graph Edition

Objective

What are we learning about?

Students will learn to identify and explain misleading elements in graphs, developing critical thinking skills and understanding how data can be manipulated in visual representations.

Materials

What you will need for the activity

- A set of printed graphs (some accurate, some misleading)
- Smartboard or projector for the graphs



Instructions

How to complete the activity

1. Begin by explaining the concept of misleading graphs to the students, highlighting common ways graphs can be manipulated (e.g., truncated y-axes, omitting data, exaggerating differences).
2. Show each graph one at a time on the smartboard or projector to ensure all students can see the graph clearly.
3. After showing each graph, ask the students to use finger counts to indicate their decision. They show one finger if they believe the graph is true and two fingers if they believe the graph is misleading (or vice versa, depending on the activity design).
4. Once all students have made their decisions, invite a few students to explain their reasoning. Ask them to point out specific elements of the graph that make it true or misleading, such as the use of a misleading scale or omitted data.
5. Facilitate a class discussion to reinforce key concepts, summarizing the points made by the students and providing additional examples if necessary.
6. Repeat steps 3-4 for each graph in the set. Encourage students to look for new elements that might be misleading as they view different graphs.
7. After all graphs have been discussed, ask the students to reflect on what they have learned. Provide them with questions to think about or answer in their math journals or as a group.

Graph

What do you notice about the graph?

Two friends, Alex and Jamie, tracked the hours they spent exercising from Monday to Friday. The graph compares their daily workout routines over the course of the week.

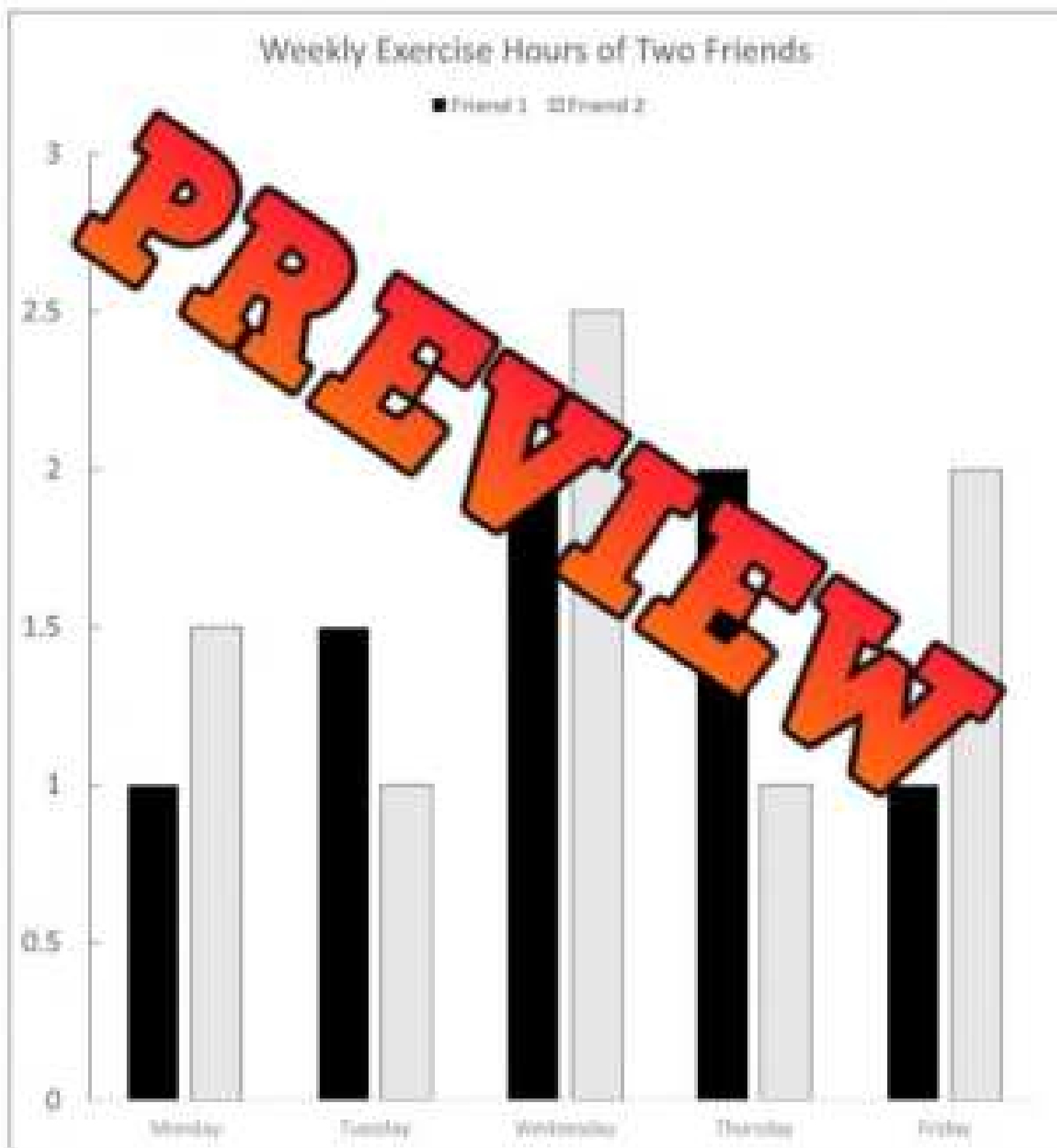

Graph

What do you notice about the graph?

A local bakery recorded its monthly sales over the first half of the year. The graph illustrates the sales trends, aiming to show a rapid increase in income.



Graph

What do you notice about the graph?

Two households tracked their internet usage from January to May to monitor their data consumption. The graph displays how much data each household used each month.



Graph

What do you notice about the graph?

A group of students tracked how much time they spent on different homework subjects—Math, Science, English, History, and Art. The circle graph displays how their time was divided between the subjects.

Time Spent on Different Homework Subjects

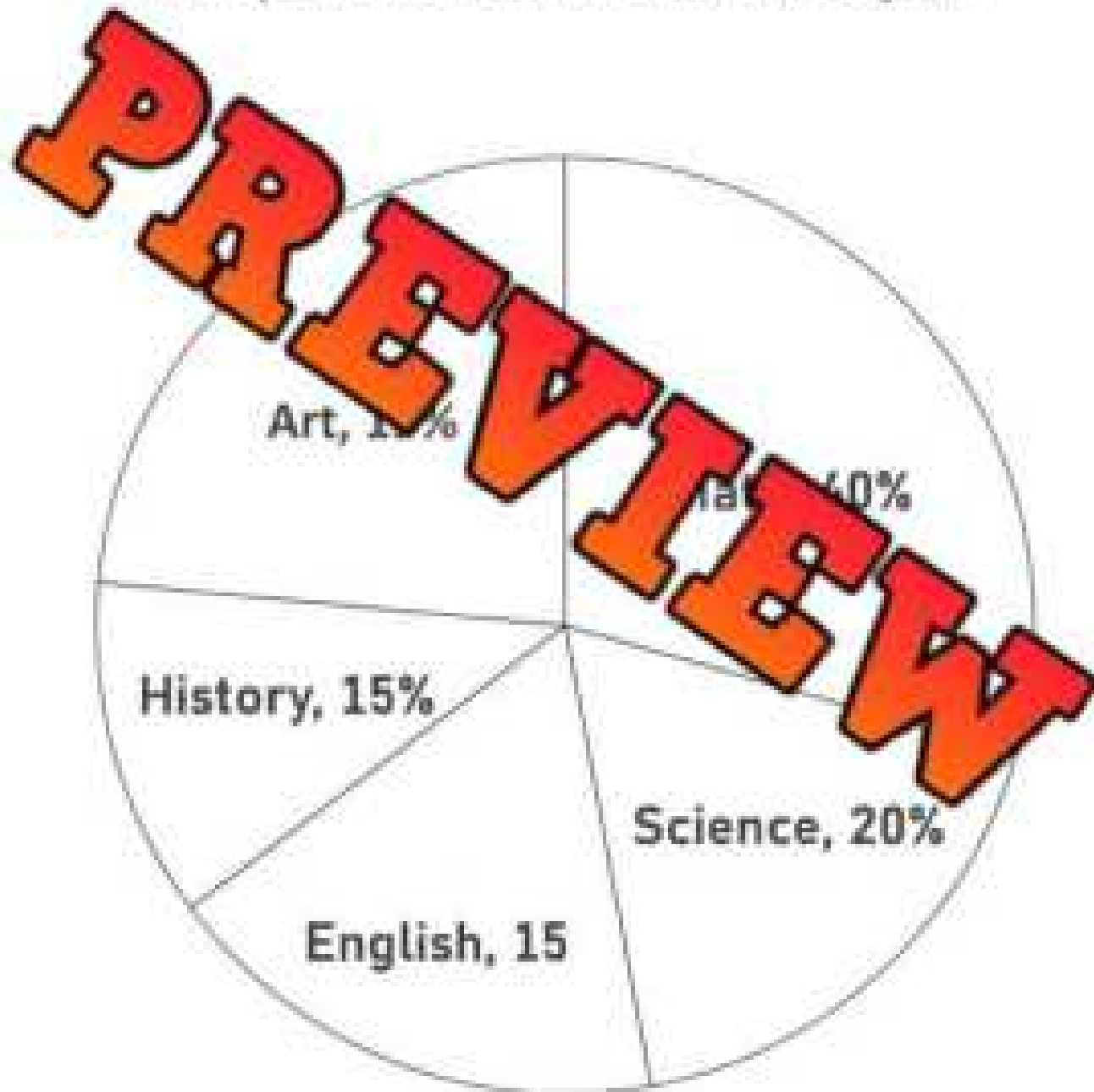

Graph

What do you notice about the graph?

The graph shows how temperatures fluctuated in a city over the course of a week, from Monday to Sunday.

Temperature Change Over a Week



Graph

What do you notice about the graph?

A recycling facility is against the use of plastic for packaging, so they track the types of waste processed—paper, plastic, metal, and glass—and displayed them as a percentage of the total waste processed at their facility.

Types of Waste in a Recycling Facility

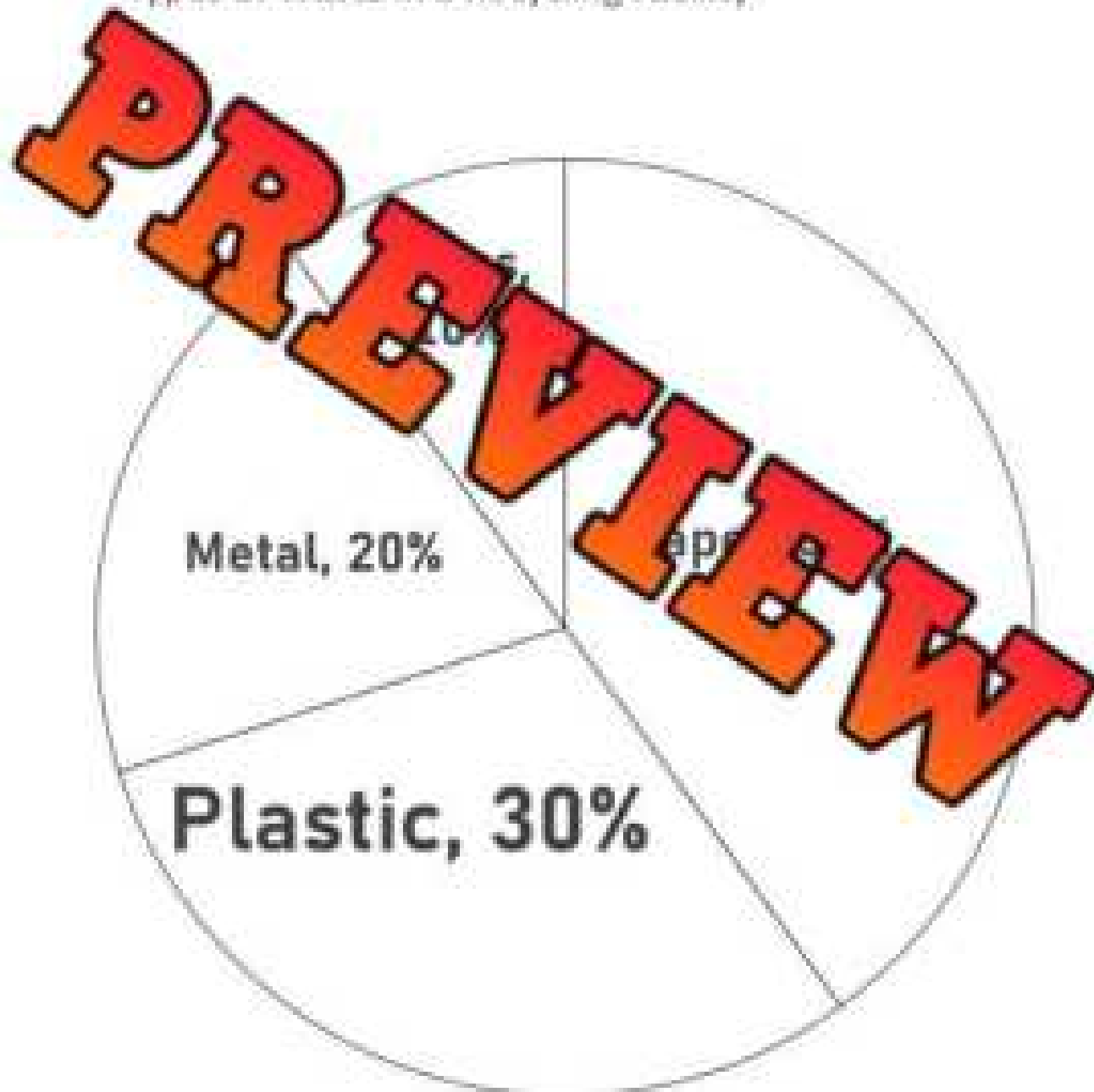

Graph

What do you notice about the graph?

This graph compares the average salaries in two professions—Engineering and Marketing—over five years. The graph was made by professionals in the field of engineering and marketing who believe their incomes have not increased enough.

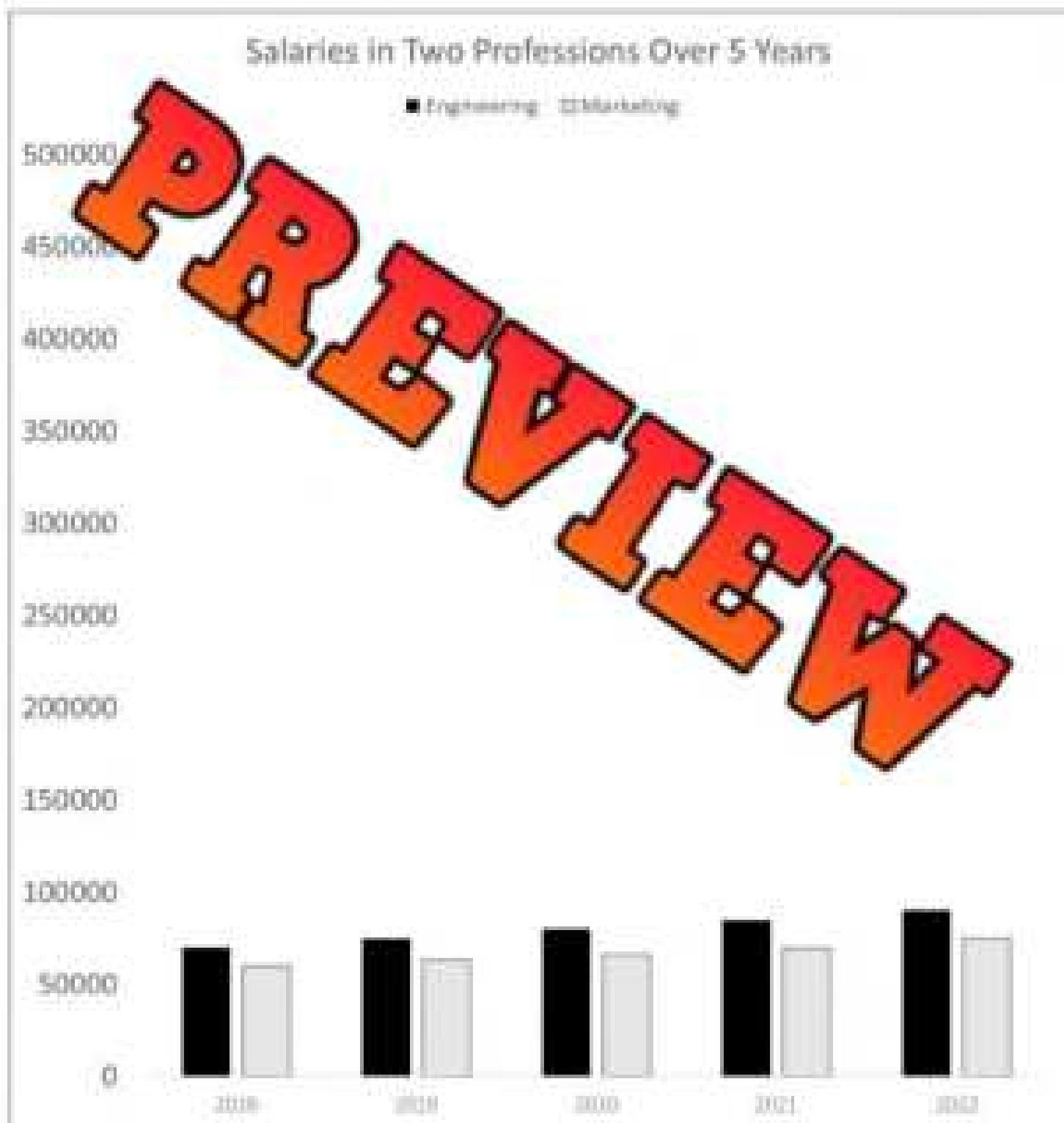

Unit Test – Data Analysis

Part 1

Is the example one-variable or two-variable data? Use a checkmark ✓

Example	One-Variable	Two-Variable
1) Favourite subject in school.		
2) How many minutes studied and mark received on test		
3) How many fans in attendance and how loud the arena is		
4) How many points a player scores in a season		
5) How many hours practicing piano and mistakes made		
6) How many songs on a CD		

Part 2

Does the graph represent one or two variables? Describe both variables

Lemonade Sales vs Temperature

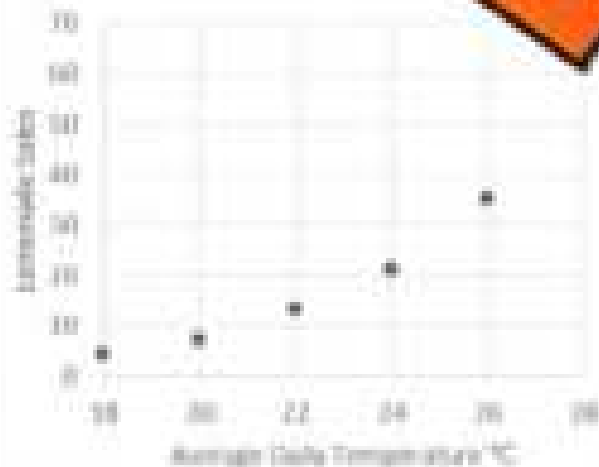

Does the graph represent one or two variables?

Describe variable number 1

2a)

Describe variable number 2 (if applicable)

2b)

Distance-Time Graph - Race

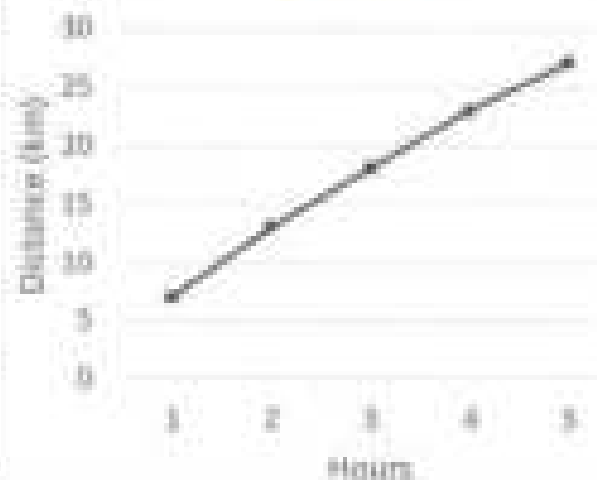

Does the graph represent one or two variables?

1)

Describe variable number 1

2a)

Describe variable number 2 (if applicable)

2b)

Part 3

Circle the graph you would use to represent the data

	Description	Graph A	Graph B
1)	You are displaying two sets of data from grade 7s and grade 8s	Multiple Bar Graph	Histogram
2)	You want to show the relationship between two variables	Histogram	Scatter Plot
3)	You want to graph continuous data	Broken-Line	Histogram
4)	You have categorical data and want to represent each category as parts of a whole	Broken Line Graph	Circle Graph
5)	You are graphing test scores from students in three categories: 70-80, 80-90 and 90-100	Broken-Line Graph	Histogram

Part 4

Circle the relationship between the variables

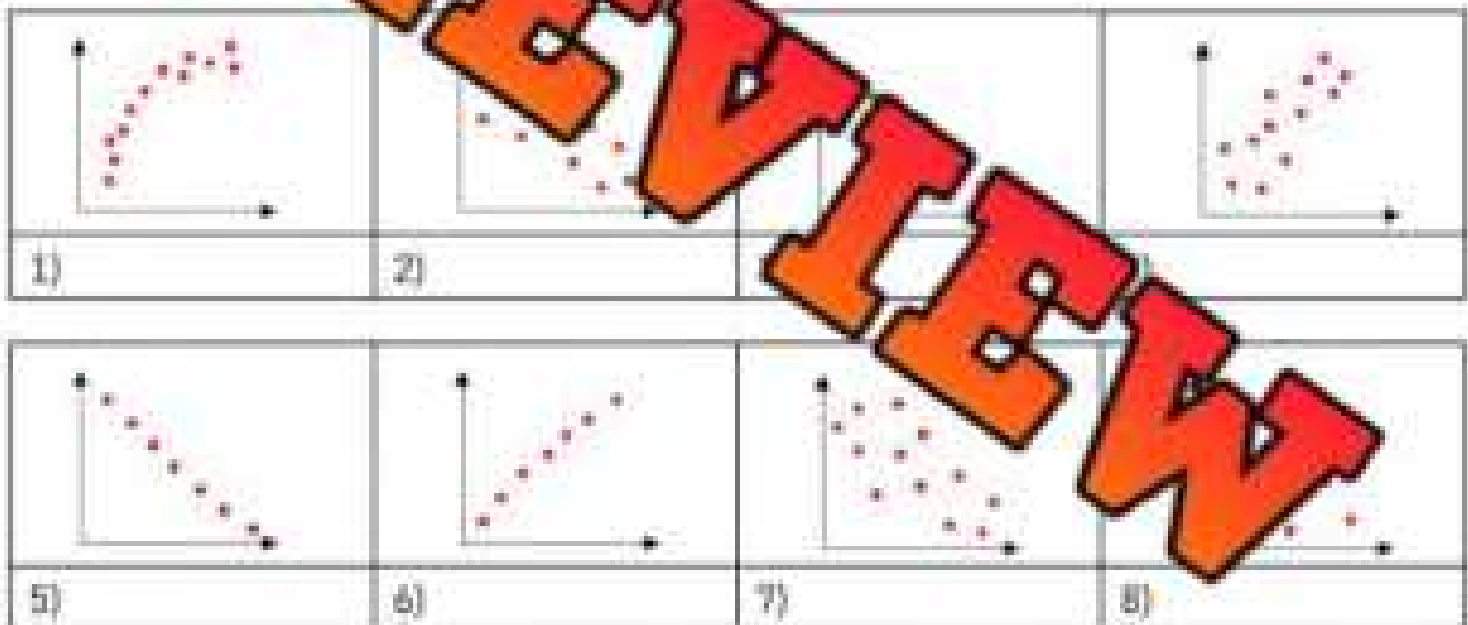

Part 5

Describe what type of relationship the variables would have. Explain.

	Variable 1 (x-axis)	Variable 2 (y-axis)	Relationship
	Number of times you have been on an airplane	Fear of flying (scale from 1 - 10)	
Explain	<hr/> <hr/>		

Part 7

Display the data below in a scatter-plot

Harris has an online business selling his artwork. He tracked how many views he had of his store and how many sales he had for the last 17 days.

Views	# of Sales
1	1
5	3
4	2
3	2
6	5
8	1
5	4
4	4
9	9
10	8
7	5
5	4
6	4
8	5
8	5
11	1



Part 8

Answer the questions below

- 1) What outlier did you notice?
- 2) What caused the outlier?
- 3) Draw a line of best fit. How many sales would you expect if Harris had 12 views?
- 4) What is the relationship between the variables?

Grade 8 D2. Probability

	Curriculum Expectations	Pages That Cover the Expectations
D2.1	solve various problems that involve probability, using appropriate tools and strategies, including Venn and tree diagrams	127 - 138, 160 - 163
D2.2	determine and compare the theoretical and experimental probabilities of multiple independent events happening and of multiple dependent events happening	124 - 126, 139 - 159, 164 - 165

Independent Events – Darts



Independent events are two or more events that could happen at the same time without affecting the outcomes of the other events. Imagine below, that the shaded in area is a target and the white part is the wall. What is the probability of you hitting the target twice if you had two throws?

Questions

What is the probability of you hitting the target twice if you had two throws?

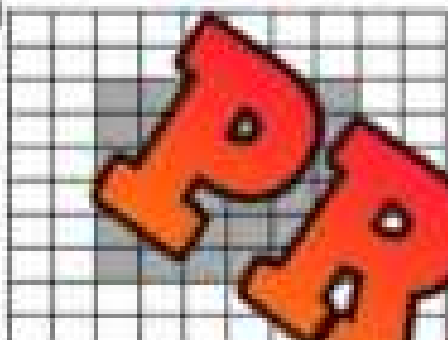
1) 

Fraction	Decimal	Percent

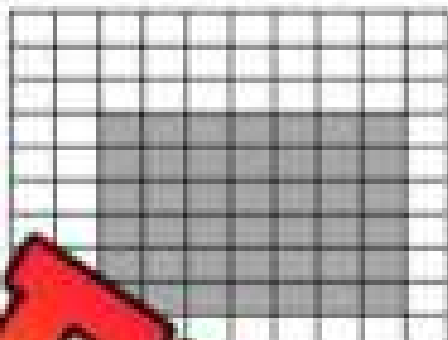
2) 

Fraction	Decimal	Percent

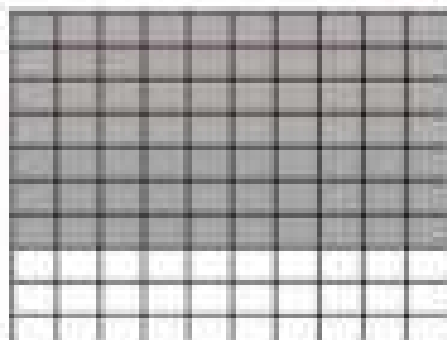
3) 

Fraction	Decimal	Percent

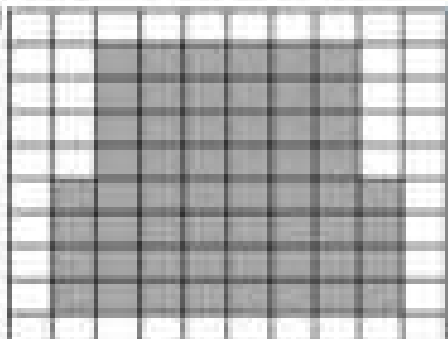
4) 

Fraction	Decimal	Percent

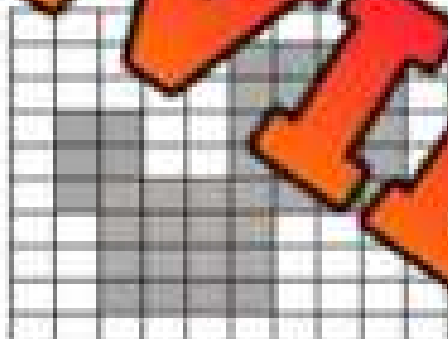
5) 

Fraction	Decimal	Percent

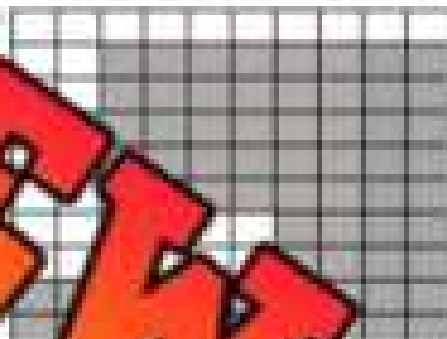
6) 

Fraction	Decimal	Percent

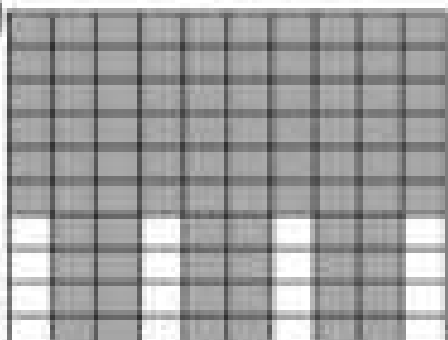
7) 

Fraction	Decimal	Percent

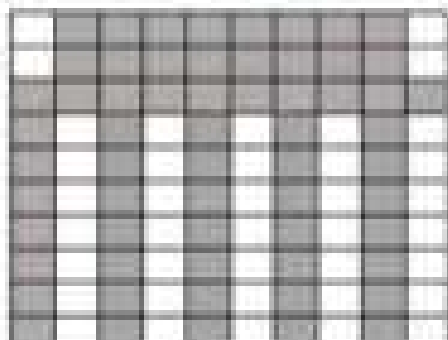
8) 

Fraction	Decimal	Percent

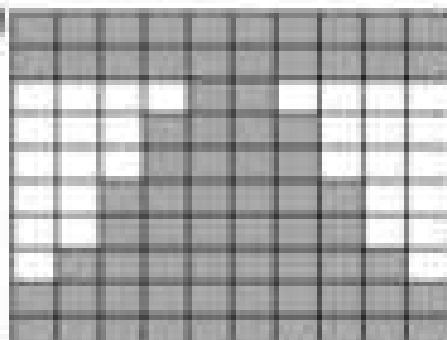
9) 

Fraction	Decimal	Percent

Independent Events – Rolling a Dice

Rolling a Dice

A dice has 6 sides. Each side has a number of dots between 1 and 6. When you roll a dice, you have an unlikely chance of rolling a certain number.

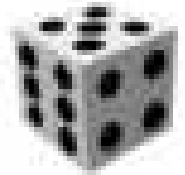

Questions

What is the probability of...

1) Rolling a 1

Fraction	Decimal	Percent

2) Rolling a 2

Fraction	Decimal	Percent

3) Rolling an odd number?

Fraction	Decimal	Percent

4) Rolling two six-sided dice and getting two 6's

Fraction	Decimal	Percent

5) Rolling two six-sided dice and getting a 1, 2, or 3 on both rolls?

Fraction	Decimal	Percent

6) Rolling two six-sided dice and getting an even number on both?

Fraction	Decimal	Percent

7) When rolling 2 dice, what is the probability of rolling a 1, 2, 3, 4, or 5 on both rolls?

Fraction	Decimal	Percent

Calculating Probability – Venn Diagram

At a wedding reception, the guests had 2 options for dinner – steak or vegetarian. Of the 50 guests at the reception, 30 are having steak, 20 are having vegetarian and 6 hungry guests are having both.

Part 1

Fill in the Venn diagram with the data above

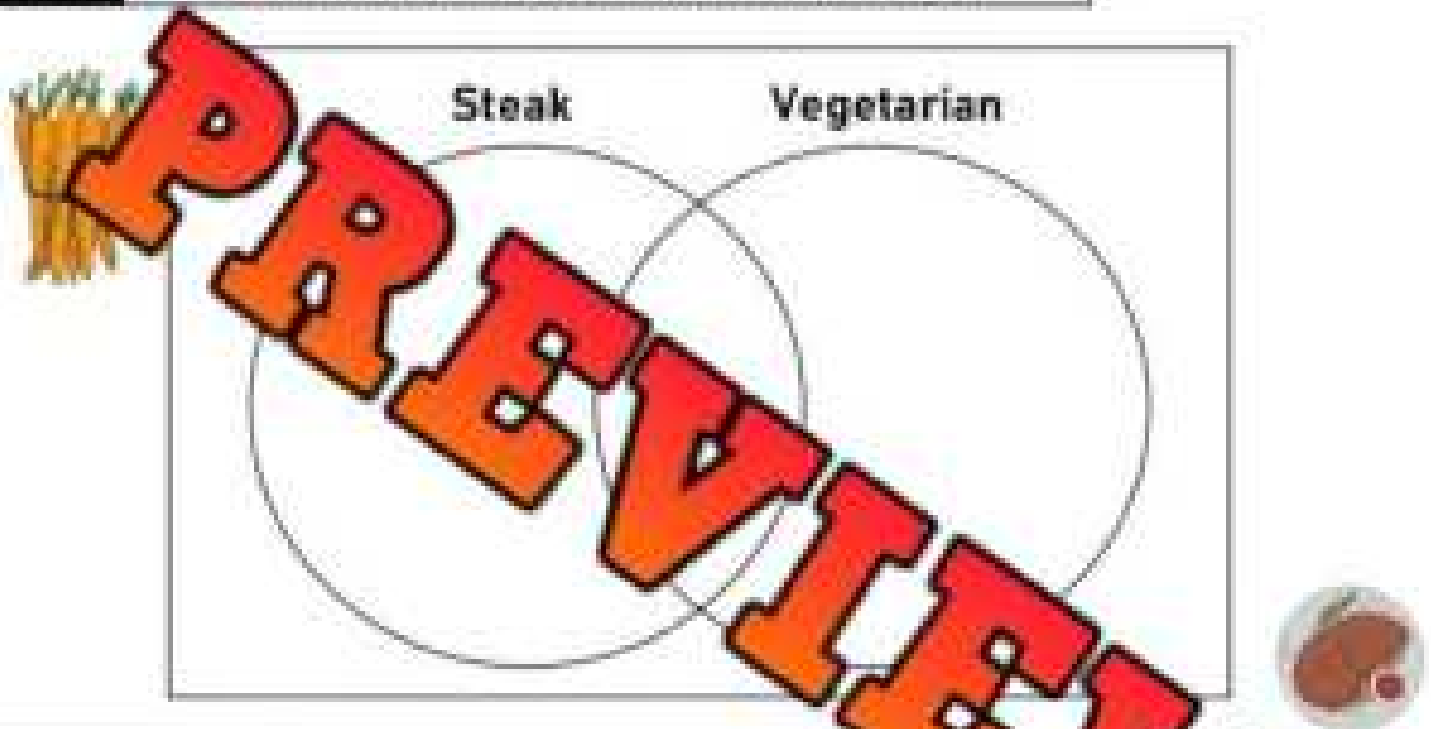

Part 2

Answer the questions below

Questions – What is the probability that a randomly selected guest...		Fraction	Dec	Percent
1)	ordered steak			
2)	ordered vegetarian			
3)	ordered steak or vegetarian but not both			
4)	ordered steak and vegetarian			
5)	didn't order a meal			
6)	ordered steak but not vegetarian			
7)	ordered vegetarian but not steak			

Exit Cards

Cut Out Cut out the exit cards below and have students complete them at the end of class.

Name: _____

At a local sports event, participants had two options for activities – soccer or basketball. Out of the 60 participants, 35 are playing soccer, 25 are playing basketball, and 10 participants are playing both sports.

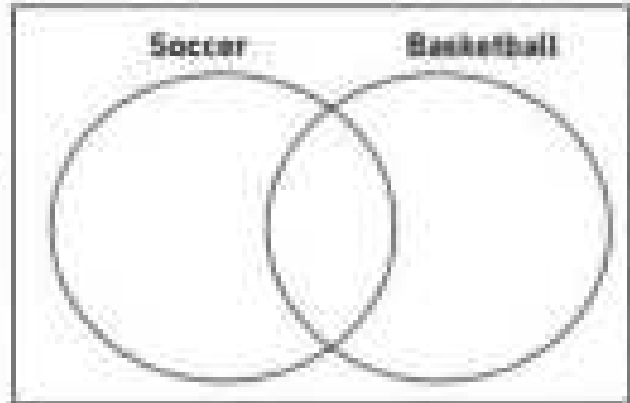

2) What is the probability that a randomly selected participant...	Fraction	Decimal	Percent
a) played soccer?			
b) played basketball?			
c) played soccer or basketball but not both?			
d) played both soccer and basketball?			
e) didn't participate in any activity?			

Name: _____

At a local sports event, participants had two options for activities – soccer or basketball. Out of the 60 participants, 35 are playing soccer, 25 are playing basketball, and 10 participants are playing both sports.



2) What is the probability that a randomly selected participant...	Fraction	Decimal	Percent
a) played soccer?			
b) played basketball?			
c) played soccer or basketball but not both?			
d) played both soccer and basketball?			
e) didn't participate in any activity?			

PREVIEW

Calculating Probability – Venn Diagram

In a class of 30 students, 14 are wearing a sweater, 16 are wearing a t-shirt and 7 are wearing both.

Part 1

Fill in the Venn diagram with the data above

Sweater

T-shirt



Part 2

Answer the questions below

	What is the probability that a randomly selected student is wearing...	Fraction	Decimals	Percent
1)	a sweater			
2)	a sweater but not a t-shirt			
3)	a t-shirt			
4)	a t-shirt but not a sweater			
5)	neither a sweater nor a t-shirt			
6)	a sweater and a t-shirt			
7)	a sweater or a t-shirt but not both			

Calculating Probability – Venn Diagram

Part 1

Fill in the Venn diagram with the data below

21 students were surveyed about their hair

Curly	Long	Short
Elle		Logan
Henry		Henry
Liam		Lucas
Sofia	Lily	
Nova	Liam	Nina
Riley	Nora	Lucas
Julian	Julian	Liam
Nora	Nora	David
	Elena	Ben
	Owen	Eddie
	Violet	

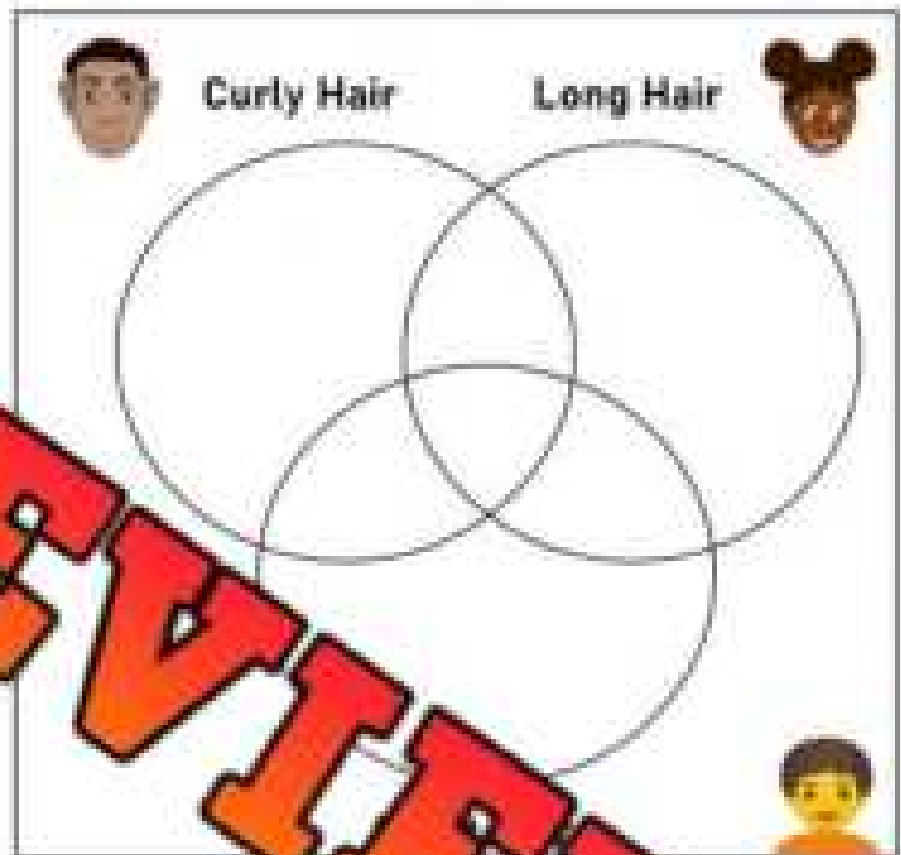

Part 2

Answer the questions below

What is the probability that a randomly selected student...		Fraction	Decimal	Percent
1)	has curly hair			
2)	has long hair			
3)	has short hair			
4)	does not have curly hair			
5)	has curly short hair			
6)	has curly long hair			
7)	has short hair that isn't curly			
8)	has long hair that isn't curly			

Calculating Probability – Venn Diagram

Part 1

Fill in the Venn diagram with the data above

100 people were surveyed about which sports they play

- 33 play basketball
- 45 play soccer
- 41 play hockey
- 8 play both soccer and hockey
- 9 play both soccer and basketball
- 6 play all three sports

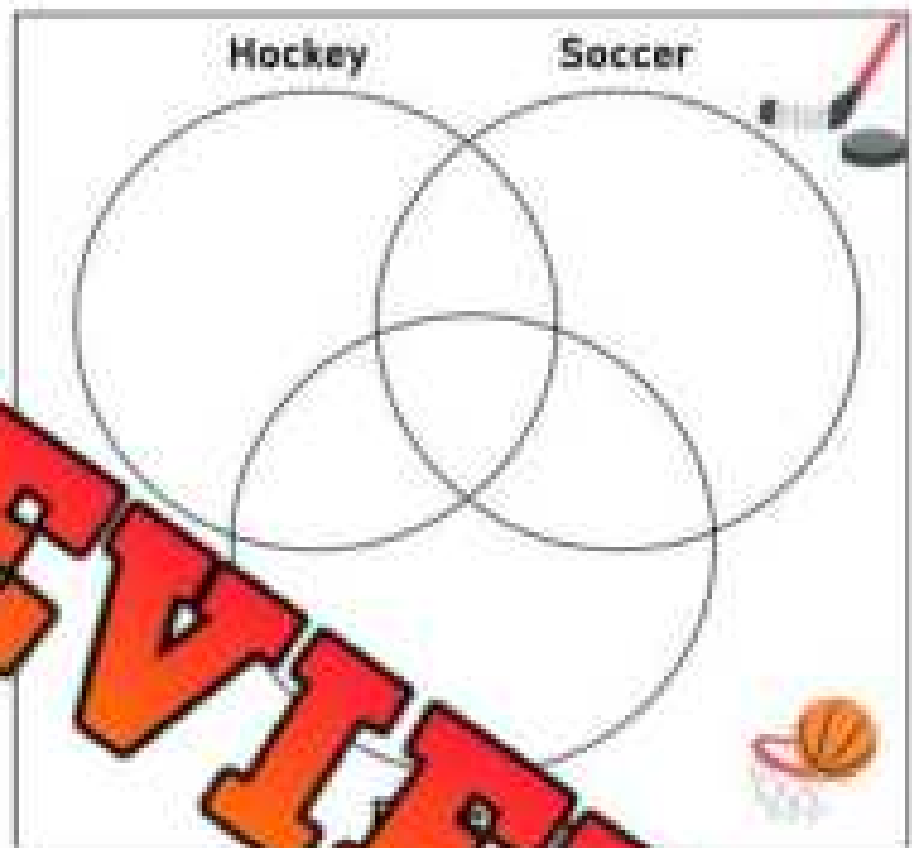

Part 2

Answer the questions below

What is the probability that a randomly selected person...		Fraction	Decimal	Percent
1)	plays hockey			
2)	plays just hockey and not soccer or basketball			
3)	plays soccer			
4)	plays basketball and soccer but not hockey			
5)	plays basketball			
6)	plays all three sports			
7)	doesn't play hockey, soccer, nor basketball			
8)	plays hockey and soccer but not basketball			

Calculating Probability – Venn Diagram

Questions

Answer the questions below using Venn diagrams.

1) In a class of 24 students:

- 12 play the guitar
- 13 play the piano
- 5 play both the guitar and the piano



	What is the probability that a randomly selected student...	Percent
a)	plays the piano	
b)	plays just the guitar and not the piano	
c)	plays neither the guitar nor the piano	

2) In a company, there were 80 workers:

- 50 workers like coffee
- 41 workers like tea
- 20 workers like both coffee and tea



	What is the probability that a randomly selected worker...	Percent
a)	likes coffee and tea	
b)	likes just tea and not coffee	
c)	likes neither coffee nor tea	

Tree Diagrams – Independent Events

Questions Draw a tree diagram to show how many different combinations you could have

An ice cream shop sells different cones, ice cream, and toppings. Their menu is listed below.



Cones	Ice Cream	Toppings
Sugar Cone (S)	Vanilla (V)	Butterscotch (B)
Waffle Cone (W)	Chocolate (C)	Fudge (F)



Combinations

1) How many combinations of ice cream could you have?

2) What is the probability of a customer ordering a...	Fraction	Decimal	Percent
a) sugar cone with vanilla ice cream and fudge			
b) sugar cone with chocolate ice cream and butterscotch			
c) waffle cone with chocolate or vanilla and fudge			
d) waffle or sugar cone with vanilla ice cream and fudge or butterscotch			
e) sugar cone with chocolate and fudge or butterscotch			
f) sugar or waffle cone with vanilla or chocolate ice cream and butterscotch or fudge toppings			

Drawing Tree Diagrams

Questions

Draw a tree diagram to help you find the probability of different combinations.

You are having a surprise dessert at a party you are having. Your parents said it is either cookies or brownies. They also told you the options for the treats and icing. What is the probability of them choosing a specific combination of baked good, treat, and icing.

Baked Goods	Treats	Icing
Cookies (C)	Chocolate Chips (CC)	Vanilla (V)
Brownies (B)	Smarties (S)	Chocolate (CH)
	Raisins (R)	Caramel (CA)

PREVIEW

1) How many combinations of food could you have?

2) What is the probability of your parents choosing...

Fraction

Decimal

Percent

a) Cookies with chocolate chips and vanilla icing

b) Brownies with raisins and caramel icing

c) Cookies or brownies with smarties and vanilla icing

d) Cookies or brownies with raisins or smarties and vanilla or chocolate icing

e) Cookies with chocolate chips, smarties or raisins and vanilla or caramel icing

Exit Cards

Cut Out Cut out the exit cards below and have students complete them at the end of class.

Name: _____

Draw a tree diagram to help you find the probability of different combinations

You are designing an avatar, and you have the following options for customizing its outfit. You can choose one shirt colour, one pants type, and one shoe type for the avatar.

Shirt Colour	Pants Type	Shoe Type
Red (R)	Jeans (J)	Sneakers (S)
Blue (B)	Shorts (S)	Sandals (SD)
Green (G)		

Name: _____

Draw a tree diagram to help you find the probability of different combinations

You are designing an avatar, and you have the following options for customizing its outfit. You can choose one shirt colour, one pants type, and one shoe type for the avatar.

Shirt Colour	Pants Type	Shoe Type
Red (R)	Jeans (J)	Sneakers (S)
Blue (B)	Shorts (S)	Sandals (SD)
Green (G)		

PREVIEW

Determining Probability of Multiple Events

Questions

Solve each problem

1) A customer walks in Premiere Pizza where you can order one type of pizza and a drink for \$6. The menu is below

Pizza	Drink
Pepperoni	Soda
Onion	Juice
Mia	Mia

- a) How many combinations could the customer order?
- b) What is the probability the customer orders bacon pizza with juice?
- c) What is the probability the customer orders onion or pepperoni pizza with juice or soda?

2) Your teacher teaches 3 classes in the morning. The options for each class are below

Class 1	Class 2	Class 3
Math	Music	Social Studies
Language	French	Science
Health	Drama	Gym

- a) How many combinations could your teacher choose?
- b) What is the probability your teacher chooses math, music or drama, and gym?
- c) What is the probability your teacher chooses French, drama or French, and science or gym?

3) At a fancy restaurant, you can order a surprise dinner. They tell you the options for the meat, vegetables, and dessert.

Meat	Vegetables	Dessert
Chicken	Potatoes	Cake
Steak	Salad	Brownie
Fish	Corn	

- a) How many combinations could the chef make?
- b) What is the probability the chef makes steak or chicken with potatoes and cake?
- c) What is the probability the chef makes chicken or fish with corn or salad and brownie?

4) Your mom is getting you with your dress and shoes. She has

Top	Bottom	Shoes	Head
Shirt	Jeans	Sneakers	Hat
Sweater	Shorts	Sandals	Cap
Jersey	Jogs		

- a) How many combinations could your mom pick?
- b) What is the probability your mom picks a shirt with pants and shoes and a cap?
- c) What is the probability your mom picks a jersey or shirt with jogs and sandals or shoes with a toque?

Independent Events – Dice Challenge

Part 1 Find the probability of each sum when two dice are rolled



- 1) What is the probability of you rolling two six-sided dice and getting a sum of the two dice greater than 7?
- 2) What is the probability of you rolling two six-sided dice and getting a sum of the two dice less than 10?
- 3) What is the probability of you rolling two six-sided dice and getting a sum of the two dice less than 4?

+	1	2	3	4	5	6
1						
2						
3						
4						
5						
6						



Part 2 Find the probability of each product when two dice are rolled

x	1	2	3	4	5	6
1						
2						
3						
4						
5						
6						

- 1) What is the probability of you rolling two six-sided dice and getting a product of the two dice greater than 24?
- 2) What is the probability of you rolling two six-sided dice and getting a product of the two dice less than or equal to 15?
- 3) What is the probability of you rolling two six-sided dice and getting a product of the two dice greater than or equal to 24?



Independent vs Dependent Events

Two events are **independent events** if the outcome of one event does not affect the outcome of the other. Example - flipping a coin twice or rolling a dice and flipping a coin.

Two events are **dependent events** if the outcome of one event affects the outcome of the other. Example - drawing names from a hat (the number of names decreases after each draw, which affects the probability of the next event(s)).

Questions Are the events independent or dependent?



1)	Rolling a die and drawing a card from a box of different coloured cards	Dependent	Independent
2)	Performing a magic trick on a dog and landing on 300 on a roulette wheel	Dependent	Independent
3)	Snowing today and snowing tomorrow	Dependent	Independent
4)	Randomly selecting two t-shirts from a wardrobe that is full of multi-coloured shirts	Dependent	Independent
5)	A teacher hands out candy from their bin of different types of candy	Dependent	Independent
6)	Making 5 three pointers in a row	Dependent	Independent
7)	Your teacher is selecting 2 students to help them. You hope you and your best friend get chosen.	Dependent	Independent
8)	Drawing a heart from a deck of cards and then drawing another heart from the same deck of cards	Dependent	Independent
9)	Drawing an 8 from a deck of cards and then drawing an 8 from a different deck of cards	Dependent	Independent
10)	You winning 3 hockey games in a row	Dependent	Independent
11)	Winning today's race and next week's race	Dependent	Independent
12)	Flip a coin and select a card from a deck of cards	Dependent	Independent

Dependent Events – Money Bag

A bag has one of each Canadian coins - 5¢, 10¢, 25¢, \$1, \$2.

What is the probability you will select a dime and then a quarter?

Solution

Probability to pick a Dime is $\frac{1}{5}$

Probability to pick a Quarter is $\frac{1}{4}$ (no dime in the bag)

Desired probability = $\frac{1}{5} \times \frac{1}{4} = \frac{1}{20}$



Questions: What is the probability of the following scenarios:

	Scenario	Answer - Show Your Work
1)	Selecting a Toonie?	
2)	Selecting a Quarter and then a Loonie?	
3)	Selecting a Nickel and then a Dime, and then a Loonie?	
4)	Selecting a Toonie, and then a Loonie, and then a Nickel?	
5)	Selecting the following coins in the order presented: Nickel, Quarter, Toonie, Dime?	
6)	Selecting the following coins in the order presented: Nickel, Dime, Quarter, Loonie, Toonie?	

Dependent Events – Prize Box



Question: Find the probability of the following scenarios.

	Scenario	Answer - Show Your Work
1)	You get one pick. What is the likelihood of picking a book?	
2)	You get two picks. What is the likelihood of picking a set of headphones first and a pencil second?	
3)	You get three picks. What is the likelihood of picking a baseball first, a pencil second, and a phone third?	
4)	You get four picks. What is the likelihood of picking a phone first, a basketball second, headphones third, and a hairbrush fourth?	
5)	You are picking from the prize box third. One phone and one set of headphones are already gone. What is the likelihood of you picking a phone?	
6)	You are picking from the prize box fifth. One phone, one hairbrush, and two baseballs are already gone. You get two picks. What is the likelihood of you picking a phone first and then headphones second?	

Theoretical vs Experimental Probability

Theoretical Probability

What should happen

Example - The theoretical probability of flipping a heads is 1 time out of 2 or $\frac{1}{2}$.

Experiment Probability

What did happen after the event (experiment)

Example - You flipped a coin 10 times and got 7 heads. The experimental probability is $\frac{7}{10}$.

Part 1

Write the theoretical probability of the events happening below

Question	Fraction	Decimal	Percent
1) What is the theoretical probability of flipping a heads?			
2) What is the theoretical probability of flipping a tails?			
3) What is the theoretical probability of flipping a heads if you flipped the coin 10 times?			
4) What is the theoretical probability of flipping a heads and then rolling a dice and getting a 3?			
5) What is the theoretical probability of getting an odd number and then flipping a heads?			

Part 2

Experimental Probability - Flip a coin 20 times and record your results

1) How many heads and tails do you think you will flip?

Tails

20

2) Perform the experiment by flipping a coin 20 times. Record how many heads and tails you get.

	Tallies	Frequency	Fraction	Decimal	Percent
Heads					
Tails					

3) Was the theoretical probability and experimental probability the same? Should it be the same? Explain.

Theoretical vs Experimental Probability

Examples of Theoretical and Experimental Probability

Theoretical: You should roll a 3 once every 6 rolls = $\frac{1}{6}$

Experimental: You rolled a 3 twice when you rolled a dice six times = $\frac{2}{6}$



Part 1

Circle if the example is theoretical or experimental

Example	Theoretical	Experimental
1) There is a 30% chance of rain today	<input type="checkbox"/>	<input type="checkbox"/>
2) You flipped a coin 10 times and got heads 3 times	<input type="checkbox"/>	<input type="checkbox"/>
3) You have a 1/52 chance of pulling a heart from a deck of cards	<input type="checkbox"/>	<input type="checkbox"/>
4) A scratch card has a 1/10 chance of winning a prize	<input type="checkbox"/>	<input type="checkbox"/>
5) Your batting average is 0.25, which is a hit 1 in 4	<input type="checkbox"/>	<input type="checkbox"/>
6) You made 4 of 10 three pointers	<input type="checkbox"/>	<input type="checkbox"/>
7) Saabicult won the race even though he was 100th	<input type="checkbox"/>	<input type="checkbox"/>
8) The Toronto Raptors won 4/7 games	<input type="checkbox"/>	<input type="checkbox"/>
9) You have a 1/80 chance of winning a giveaway by drawing a name	<input type="checkbox"/>	<input type="checkbox"/>
10) You won a cross-country race with 90 people	<input type="checkbox"/>	<input type="checkbox"/>

Part 2

Is the example [theoretical] or experimental? What is the probability?

Example	Theoretical or Experimental	Fraction	Decimal	Percent
1) You should make 8 in 10 free throws				
2) You buy one raffle ticket out of 90 that are sold				
3) You rolled a dice 10 times and got a 3, 4 times				
4) You pulled 20 cards from a deck of cards and got 5 red ones				
5) There is a 35% chance of precipitation				

Exit Cards

Cut Out Cut out the exit cards below and have students complete them at the end of class.

Name: _____

Answer the following questions.

1) You roll a fair die, and based on theory, each number should appear once every 6 rolls = $\frac{1}{6}$.

Circle Answer: Theoretical or Experimental

2) A bag contains 5 blue marbles and 5 red marbles. You picked 5 blue marbles out of 9 picks from the bag.

Circle Answer: Theoretical or Experimental

3) Fill the table

Example	Theoretical or Experimental	Fraction	Decimal	Percent
The probability of getting an ace from a deck of cards is $\frac{1}{13}$.				

Name: _____

Answer the following questions.

1) You roll a fair die, and based on theory, each number should appear once every 6 rolls = $\frac{1}{6}$.

Circle Answer: Theoretical or Experimental

2) A bag contains 5 blue marbles and 5 red marbles. You picked 5 blue marbles out of 9 picks from the bag.

Circle Answer: Theoretical or Experimental

3) Fill the table

Example	Theoretical or Experimental	Fraction	Decimal	Percent
The probability of getting an ace from a deck of cards is $\frac{1}{13}$.				

Name: _____

Answer the following questions.

1) You roll a fair die, and based on theory, each number should appear once every 6 rolls = $\frac{1}{6}$.

Circle Answer: Theoretical or Experimental

2) A bag contains 5 blue marbles and 5 red marbles. You picked 5 blue marbles out of 9 picks from the bag.

Circle Answer: Theoretical or Experimental

3) Fill the table

Example	Theoretical or Experimental	Fraction	Decimal	Percent
The probability of getting an ace from a deck of cards is $\frac{1}{13}$.				

Name: _____

Answer the following questions.

1) You roll a fair die, and based on theory, each number should appear once every 6 rolls = $\frac{1}{6}$.

Circle Answer: Theoretical or Experimental

2) A bag contains 5 blue marbles and 5 red marbles. You picked 5 blue marbles out of 9 picks from the bag.

Circle Answer: Theoretical or Experimental

3) Fill the table

Example	Theoretical or Experimental	Fraction	Decimal	Percent
The probability of getting an ace from a deck of cards is $\frac{1}{13}$.				

Activity – Math Hot Seat: Probability Showdown

Objective

What are we learning about?

Students will practice differentiating between theoretical and experimental probability by participating in a fun and interactive game, enhancing their ability to understand probability concepts.



Material

you will need for the activity

- Index cards with probability questions (theoretical and experimental)
- Chairs arranged in a circle
- Stopwatch or timer
- Whiteboard and markers

Instructions

How you will implement

1. Prepare a stack of index cards with various probability questions. Ensure some questions ask students to identify theoretical probability and others to calculate experimental probability.
2. Arrange chairs in a circle with one "hot seat" in the middle.
3. Explain the rules of the game to the students. One student will sit in the hot seat while the rest sit in the surrounding chairs.
4. The teacher will read a probability question from the stack. The student in the hot seat has a limited time (e.g., 30 seconds) to answer the question.
5. If the student in the hot seat answers correctly within the time limit, they stay in the hot seat for the next round. If they answer incorrectly or run out of time, they switch places with another student from the circle.
6. Continue the game until each student has had the opportunity to sit in the hot seat multiple times, or until the designated game time is up.
7. Keep track of the number of correct answers each student provides while in the hot seat. The student with the most correct answers at the end of the game wins.

Index Cards

Use the math problems below.

#	Probability Question	Answer
1	A coin is flipped 50 times and lands on heads 22 times. What is the experimental probability of heads as a percent?	44%
2	A die is rolled 10 times, and it lands on a 5 two times. What is the experimental probability of rolling a 5 as a percent?	20%
3	A deck of cards is shuffled, and one card is drawn. What is the theoretical probability of drawing a red card as a percent?	50%
4	A jar has 25 marbles, and 7 are red. What is the probability of randomly picking a red marble as a fraction?	$\frac{7}{25}$
5	A die is rolled 20 times and lands on green 6 times. What is the experimental probability of landing on green as a fraction?	$\frac{6}{20}$ or $\frac{3}{10}$
6	What is the theoretical probability of rolling a 6 on a standard die? Provide your answer as a fraction.	$\frac{1}{6}$
7	A bag has 10 balls, and 10 are red. What is the probability of drawing a red ball as a percent?	50%
8	In 25 coin flips, 14 land on tails. What is the experimental probability of tails as a fraction?	$\frac{14}{25}$
9	A die is rolled 5 times, and 8 lands on 3 one time. What is the experimental probability of rolling a 3 as a percent?	20%
10	A jar has 50 candies, and 12 are blue. What is the probability of picking a blue candy as a percent?	24%
11	What is the theoretical probability of drawing an Ace from a standard deck of cards? Provide your answer as a fraction.	$\frac{4}{52}$ or $\frac{1}{13}$
12	A spinner is divided into 4 equal sections. What is the theoretical probability of landing on one section as a percent?	25%
13	A die is rolled 20 times and lands on an even number 8 times. What is the experimental probability of rolling an even number as a fraction?	$\frac{8}{20}$ or $\frac{2}{5}$
14	A jar has 30 marbles, and 6 are green. What is the probability of picking a green marble as a fraction?	$\frac{6}{30}$ or $\frac{1}{5}$
15	What is the theoretical probability of flipping a coin and getting heads? Provide your answer as a percent.	50%
16	In a jar of 20 candies, 8 are red. What is the probability of picking a red candy as a percent?	40%
17	A spinner is spun 50 times and lands on red 18 times. What is the experimental probability of landing on red as a fraction?	$\frac{18}{50}$ or $\frac{9}{25}$
18	What is the theoretical probability of rolling a number greater than 4 on a die? Provide your answer as a fraction.	$\frac{2}{6}$ or $\frac{1}{3}$

Index Cards

Use the math problems below

#	Probability Question	Answer
19	A deck of cards has 52 cards. What is the theoretical probability of drawing a black card as a percent?	50%
20	A die is rolled 25 times and lands on a 2 six times. What is the experimental probability of rolling a 2 as a percent?	24%
21	A coin is flipped 10 times and lands on tails 7 times. What is the experimental probability of tails as a fraction?	$\frac{7}{10}$
22	What is the theoretical probability of drawing a heart from a standard deck of cards? Provide your answer as a percent.	25%
23	A bag contains 10 marbles: 5 red, 5 blue, and 5 yellow. What is the probability of picking a red marble as a percent?	33.33%
24	A coin is flipped 40 times and lands on heads 22 times. What is the experimental probability of heads as a fraction?	$\frac{22}{40}$ or $\frac{11}{20}$
25	A die is rolled 100 times and lands on a 1 100 times. What is the experimental probability of rolling a 1 as a percent?	100%
26	What is the theoretical probability of rolling a 3 on a die? Provide your answer as a fraction.	$\frac{1}{6}$ or $\frac{1}{2}$
27	In 20 flips of a coin, 8 land on tails. What is the experimental probability of tails as a percent?	40%
28	A jar contains 10 marbles, 3 are blue. What is the probability of picking a blue marble as a percent?	30%
29	A spinner has 8 equal sections, and it is spun 20 times and lands on red 4 times. What is the experimental probability of landing on red as a fraction?	$\frac{1}{5}$
30	What is the theoretical probability of drawing a King from a standard deck of cards? Provide your answer as a fraction.	$\frac{4}{13}$
31	A die is rolled 6 times, and it lands on a 4 two times. What is the experimental probability of rolling a 4 as a fraction?	$\frac{2}{6}$ or $\frac{1}{3}$
32	In a bag of 25 candies, 9 are red. What is the probability of picking a red candy as a fraction?	$\frac{9}{25}$
33	A coin is flipped 15 times and lands on heads 6 times. What is the experimental probability of heads as a fraction?	$\frac{6}{15}$ or $\frac{2}{5}$
34	A jar has 50 marbles, 18 are blue. What is the probability of picking a blue marble as a percent?	36%
35	What is the theoretical probability of rolling a number less than 3 on a die? Provide your answer as a fraction.	$\frac{2}{6}$ or $\frac{1}{3}$
36	A spinner has 6 equal sections. What is the theoretical probability of landing on one section as a fraction?	$\frac{1}{6}$

Index Cards

Use the math problems below.

#	Probability Question	Answer
37	A die is rolled 12 times and lands on a 5 four times. What is the experimental probability of rolling a 5 as a fraction?	$\frac{4}{12}$ or $\frac{1}{3}$
38	A jar contains 20 candies, and 8 are yellow. What is the probability of picking a yellow candy as a percent?	40%
39	A spinner is spun 30 times and lands on blue 12 times. What is the experimental probability of landing on blue as a fraction?	$\frac{12}{30}$ or $\frac{2}{5}$
40	What is the theoretical probability of drawing a face card from a standard deck of cards? Provide your answer as a fraction.	$\frac{12}{52}$
41	In 10 rolls of a die, the number 4 is rolled 4 times. What is the experimental probability of rolling the number 4 as a fraction?	$\frac{4}{10}$ or $\frac{2}{5}$
42	A coin is flipped 5 times and lands on heads 3 times. What is the experimental probability of landing on heads as a fraction?	$\frac{3}{5}$
43	A jar has 10 marbles, and 3 are green. What is the probability of picking a green marble as a percent?	30%
44	A spinner is spun 25 times and lands on yellow 6 times. What is the experimental probability of landing on yellow as a fraction?	$\frac{6}{25}$
45	A deck of cards has 52 cards. What is the theoretical probability of drawing a Jack as a fraction?	$\frac{4}{52}$ or $\frac{1}{13}$
46	A die is rolled 30 times, and it lands on a 6 nine times. What is the experimental probability of rolling a 6 as a fraction?	$\frac{9}{30}$ or $\frac{3}{10}$
47	A spinner is spun 10 times, and it lands on red 4 times. What is the experimental probability of landing on red as a percent?	40%
48	What is the theoretical probability of drawing a club from a standard deck of cards? Provide your answer as a percent.	25%
49	A die is rolled 4 times, and it lands on a 2 twice. What is the experimental probability of rolling a 2 as a fraction?	$\frac{2}{4}$ or $\frac{1}{2}$
50	A jar contains 25 marbles, 10 are red, and 5 are blue. What is the probability of picking a blue marble as a percent?	20%

Theoretical vs Experimental Probability - # of Events

The theoretical and experimental probability of an event happening is not guaranteed to be the same. Performing more trials in an experiment will cause the experimental probability to be closer to the theoretical probability.

Example - if you flip a coin 2 times, it is easy to picture getting heads twice in a row. That would mean the experimental probability of getting a heads was 100% or $\frac{2}{2}$. However, if you flipped the coin 100 times, it is almost impossible to get 100 heads in a row.

Part 1 How many times should you get a 1, 2, 3, 4, 5, or 6 when performing the rolls below?

	1	2	3	4	5	6
6 rolls						
12 rolls						
60 rolls						
600 rolls						
1200 rolls						

Part 2 Follow the instructions below to complete experiments.

1) Roll the dice 6 times. Tally your results.

1	2	3	4	5	6

2) Roll the dice 60 times. Record how many of each number you get.

	1	2	3	4	5	6
Tallies						
Total						

3) Did the experimental probability get closer to the theoretical probability when you rolled the dice more times? Explain why this happens.

Theoretical vs Experimental - Dice

Part 1

What is the theoretical probability of the dependent events below?

	Scenario - What is the probability of...	Probability (Fraction)	Probability (Percent)
1)	Rolling a 1 and then a 2 using a 6-sided dice		
2)	Rolling a 1 and then a 4 using a 6-sided dice		
3)	Rolling a 2 and then a 3 using a 6-sided dice		
4)	Rolling a 1 and then a 1 using a 6-sided dice		
5)	Rolling a 1 and then a 2 using a 6-sided dice		

Part 2

Follow the instructions to complete the experiments

1) The theoretical probability of rolling two 6's in a row is $1/36$ or 2.7 percent. Try this experiment for yourself by filling in the table below.

Steps:

- 1) Get 2 dice or roll one dice twice.
- 2) Every time you roll, mark 1 tally.
- 3) If you get two sixes in a row, mark a tally under the 6/6 column.
- 4) Complete 36 trials. How many times should you roll double 6?

Number of 6's	Tally	6/6

2) The theoretical probability of rolling a 1 and then a 2 is $1/36$ or 2.7 percent. Complete the same steps as above for the numbers 1 and 2. Can you get more than 1 favourable outcome in 36 rolls?

Number of Rolls - Tally	1/2

Tree Diagrams – Independent Events

Questions

Draw a tree diagram to help you find the probability of different combinations.

There is a bag full of the following different flavoured chocolates:

- 2 coconut (C)
- 2 mint (M)
- 2 salted caramel (S)



Draw a tree diagram for the following scenario:

You pull one out and then put it back in the bag before pulling another chocolate.

Tree Diagram		Combinations
1 st Draw	2 nd Draw	

1) How many combinations of chocolates could you draw?

2) What is the probability of drawing...

Fraction

Decimal

Percent

a) coconut and then mint

b) mint and then coconut

c) salted-caramel and then coconut or mint

d) coconut, mint, or salted caramel and then mint

Tree Diagrams – Dependent Events

Questions Draw a tree diagram to help you find the probability of different combinations.

There is a bag full of the following different flavoured chocolates:

- 2 coconut (C)
- 2 mint (M)
- 2 salted caramel (S)



Draw a tree diagram for the following scenario:

You pull one out and eat it before pulling another chocolate.

Tree Diagram		Combinations
1 st Draw	2 nd Draw	

1) How many combinations of chocolates could you draw?

2) What is the probability of drawing...

Fraction

Decimal

Percent

a) coconut and then mint

b) mint and then coconut

c) salted-caramel and then coconut or mint

d) coconut or salted-caramel and then mint

Tree Diagrams – Dependent Events

Questions

Draw a tree diagram to help you find the probability of different combinations

Jeremy has 10 socks in his drawer.

- 2 of the socks are white
- 2 of the socks are black
- 2 of the socks are blue
- 2 of the socks are red
- 2 of the socks are green

Brad takes out two socks one after the other.

Draw a tree diagram to represent the scenario above



PREVIEW

1) How many combinations of colours could you draw? _____

What is the probability taking out...

Fraction

Percent

2) A red sock and then a blue sock?

3) Two black socks?

4) A white sock and then a black sock?

Tree Diagram – 4 Events

Questions

Draw a tree diagram to help you find the probability of different combinations

Lane flips a coin 4 times. Draw a tree diagram that lists all the possible outcomes she could get as she flips the coins.



PREVIEW

2) How many combinations could Lane get? _____

3) In this order, what is the probability that she flips the following...

Fraction

Percent

a) heads, heads, tails, tails

b) heads, tails, heads, tails

c) tails, tails, tails, heads

d) 4 tails

e) 2 heads and 2 tails in any order

f) 1 heads and 3 tails in any order

Number Simulation – Independent Events

Part 1 Theoretical Probability – Answer the questions below

Pretend you are drawing two numbers from 1-15. Since these are independent events, you can select the same number more than once.

If you pick 2 numbers, what is the theoretical probability of...

1) Picking 2 odd numbers?

2) Picking 2 even numbers?

3) Picking 1 odd and 1 even number?

If you complete 100 trials (draw 2 numbers)

4) 10 trials, how many times did you get all odd numbers?

5) 30 trials, how many times did you get all odd numbers?

6) 100 trials, how many times did you get all odd numbers?

Part 2 Experimental Probability – Perform the experiment below

Set up the experiment by cutting the numbers out and putting them in a bag. Perform the number of trials below by selecting 2 numbers from the bag. For every selection a number, you put the number back in the bag before selecting the next number.

Complete...

1) 10 trials – how many times did you get all odd numbers?

2) 30 trials – how many times did you get all odd numbers?

3) 100 trials – how many times did you get all odd numbers?

1

2

3

4

5

6

7

8

9

10

11

12

13

14

15

Number Simulation – Dependent Events

Part 1

Theoretical Probability – Answer the questions below

Pretend you have the numbers 1-15 on slips of paper in a bag. When you draw a number, you cannot get that number again for that trial. Each trial is selecting 3 numbers. Once you have completed a trial (selected 3 numbers), the numbers go back in the bag.

If you pick 3 numbers, what is the theoretical probability of...

1) Picking 3 odd numbers?

2) Picking 3 even numbers?

3) Picking 2 odd and 1 even?

If you completed 100 trials (100 draws)

4) 10 trials, how many times would you expect to get all odd numbers?

5) 30 trials, how many times would you expect to get all even numbers?

6) 100 trials, how many times would you expect to get all odd numbers?

Part 2

Experimental Probability – Perform the experiment below

Set up the experiment by cutting out the numbers below and putting them in a bag. Perform the number of trials below by selecting 3 numbers. After you select three numbers, you put the numbers back in the bag.

Complete...

1) 10 trials - how many times did you get all odd numbers?

2) 30 trials - how many times did you get all odd numbers?

3) 100 trials - how many times did you get all odd numbers?

1

2

3

4

5

6

7

8

9

10

11

12

13

14

15

Class List – Random Selections**Challenge**

Write your answers as a fraction.

- 1) A class has 24 students. Ms. Lee is randomly picking students to hand out classroom prizes.
- What is the probability that Eli is picked first?
 - What is the probability that either Eli or his best friend Sasha is picked first?
 - What is the probability that Eli is picked first and Sasha is picked second (without replacement)?
- 2) There are 24 students in the class. Three students are chosen for lunchroom duty. The order matters.
- What is the probability that Sasha, Leo, and Jordan are chosen in that exact order?
 - Jenna was picked, but there are two picks left. What is the probability that Eli and Sasha will both be chosen in that order?
- 3) Only 7 students haven't been chosen for any jobs yet. They are: Eli, Sasha, Jordan, Tasha, Leo, Amir, and Noah.
- What is the probability that Tasha and Leo are picked next, back-to-back in that order?
 - If Tasha and Leo are picked, what is the probability Amir is picked next?
 - Amir was picked and now only 4 students remain: Eli, Sasha, Jordan, and Noah. What is the probability that Noah won't be picked?

Tree Diagrams – Dependent Events

Questions

Use the tree diagram to help you find the probability of different combinations.

There is a bag full of the following different coloured beads:

- 5 red beads
- 3 blue beads



Ivy selects 3 beads from the box. She does not replace any of the beads before the next bead was selected.

Use the tree diagram to solve the questions below.

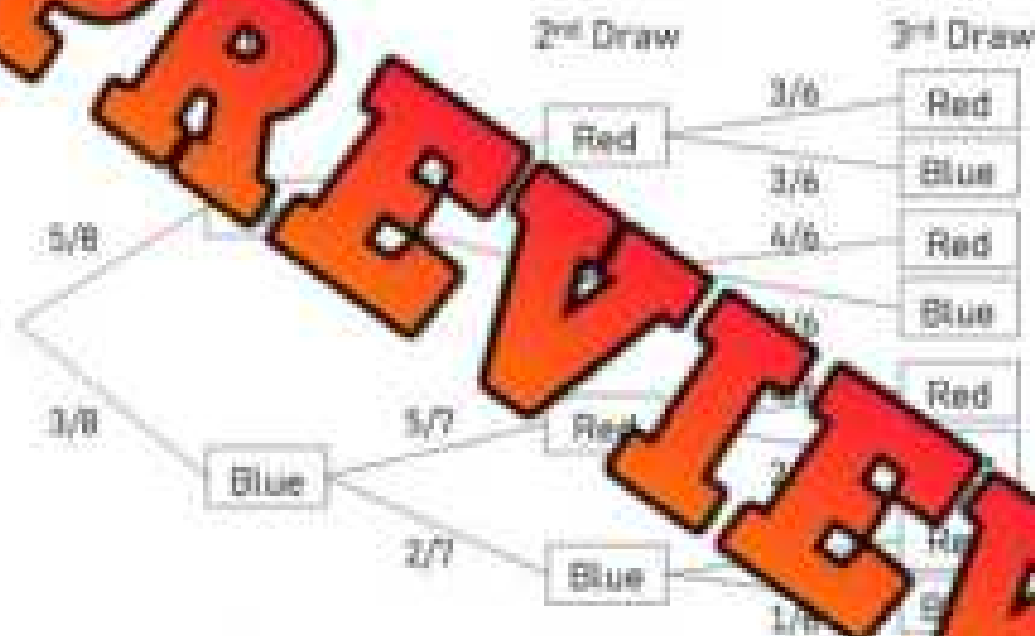

What is the probability that Ivy will select...	Fraction	Percent
1) 3 red beads?		
2) 2 red beads in a row and then 1 blue bead?		
3) 3 blue beads in a row?		
4) 1 blue bead and then 2 red beads?		
5) 2 blue beads and then a red bead?		
6) 1 red bead and then 2 blue beads?		
7) Why are these trials dependent events?		
<hr/> <hr/>		

Tree Diagrams – Dependent Events

Questions Draw a tree diagram to help you find the probability of different combinations.

There is a box of multi-coloured candy with the following candies inside:

- 7 green (G) candies
- 4 orange (O) candies



Sage will select 3 candies from the box. She will not replace any of the candies before she takes the next one.

Fill in the boxes on the tree diagrams below.



What is the probability that Sage will select...	Fraction	Percent
1) 3 green candies?		
2) 3 orange candies?		
3) 2 green candies and then 1 orange candy?		
4) 2 orange candies and then 1 green candy?		
5) 1 green candy and then 2 orange candies?		

Tree Diagram – Free Throws

Part 1 Draw a tree diagram to help you find the probability of different combinations.

When Roger goes to the free throw line in a game, he has a 0.5 chance of making the first free throw. He has a 0.4 chance of making the second free throw.

Fill in the blanks on the tree diagram below.



Part 2 Answer the questions below.

What is the probability that Roger...	Decimal	Percent
1) makes the first free throw and misses the second		
2) misses the first free throw and makes the second		
3) makes both free throws		
4) misses both free throws		

Tree Diagram – Dunk Contest

Questions

Draw a tree diagram to help you find the probability of different combinations

Ryan is in his first dunk contest. He will try to perform 3 different dunks in the contest. He has practiced each dunk and learned the following:

- He has a $\frac{3}{4}$ chance of completing the first dunk
- He has a $\frac{2}{3}$ chance of completing the second dunk
- He has a $\frac{1}{2}$ chance of completing the third dunk

Draw a tree diagram



PREVIEW

What is the probability that Ryan will...	Decimal	Percent
1) make all three dunks		
2) make his first dunk and miss his next two		
3) miss his first dunk and then make his next two		
4) miss his first and second dunk and make his third		
5) make his first and second dunk and miss his third		

Odds In Favour

Understanding Odds in Favour

Odds in favour compare the number of ways an event can happen to the number of ways it cannot happen. These are called **complementary events** because they cover all possible outcomes together.

While probability tells us the chance of an event occurring, odds are written as a ratio of favourable outcomes to unfavourable ones.

Example:

If you roll two dice, there is 1 way to get a sum of 2 and 35 ways not to.

The odds in favour of rolling a sum of 2 are 1:35 (read as "1 to 35").

This means for every 1 way to roll a 2, there are 35 ways to roll something else.

Questions

Write the odds in favour and display it as a ratio

#	Scenario	Odds in Favour - Ratio
1	A soccer player scores 1 out of 10 penalty kicks. What are the odds in favour of scoring a goal?	
2	A jar has 12 sour candies and 28 sweet candies. What are the odds in favour of pulling a sweet candy?	
3	A student guesses on a multiple choice test with 5 answer choices per question. What are the odds in favour of guessing the correct answer?	
4	A video game loot box gives a rare item 4 times out of 50 tries. What are the odds in favour of getting a rare item?	
5	A Grade 8 student has a playlist with 30 rock songs, 15 pop songs, and 5 classical tracks. What are the odds in favour of randomly hearing a rock or pop song?	
6	A library has 120 fiction books and 80 nonfiction books. What are the odds in favour of picking a fiction book at random?	

Odds In Favour

Questions

Determine the odds in favour and display it as a ratio

#	Word Problem	Odds in Favour - Ratio
1	A student rolls two dice. What are the odds in favour of getting a sum greater than 10?	
2	A basketball player makes 5 out of every 8 free throws. What are the odds in favour of making both shots in two attempts?	
3	A raffle has 50 total tickets and 10 prizes. What are the odds in favour of winning a prize if the winner is drawn?	
4	A vending machine has 8 different drinks, 3 are sodas and 5 are fruit juices. What are the odds in favour of getting a fruit juice twice in a row without replacement?	
5	A student flips 3 coins. What are the odds in favour of getting exactly 2 heads?	
6	A combination lock has digits 0-5. What are the odds in favour of guessing the 3-digit code on the first try?	

Unit Quiz - Probability

Part 1 Represent the probability of hitting the target using a fraction, decimal and percent.

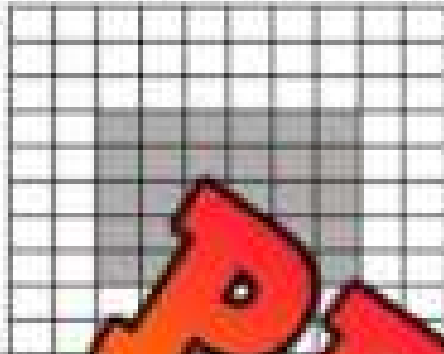
1) 

Fraction	Decimal	Percent

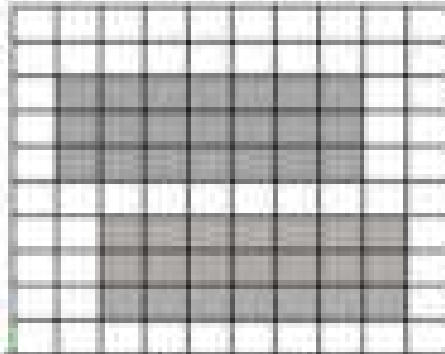
2) 

Fraction	Decimal	Percent

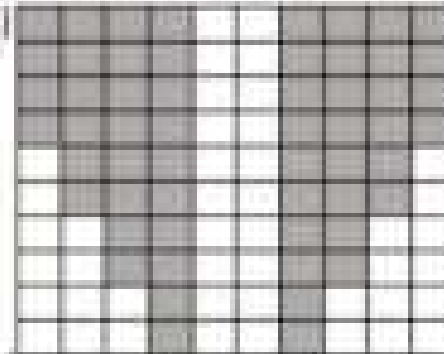
3) 

Fraction	Decimal	Percent

Part 2 What is the probability of hitting the target twice if you get 2 throws?

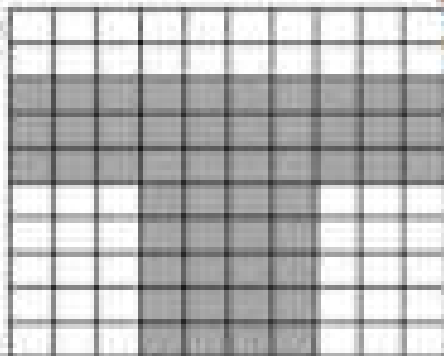
1) 

Fraction	Decimal	Percent

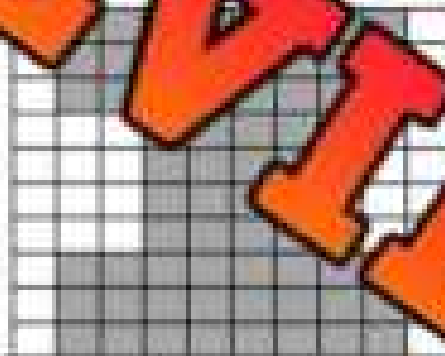
2) 

Fraction	Decimal	Percent

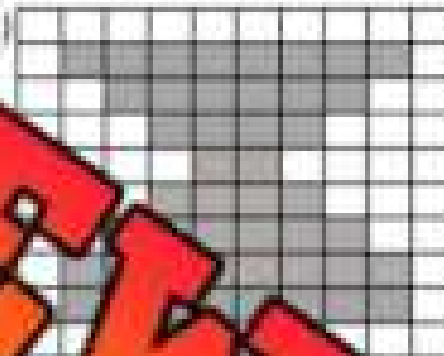
3) 

Fraction	Decimal	Percent

Part 3 Are the events independent or dependant?

1)	Raining today and then raining tomorrow	Dependent	Independent
2)	Pulling out a red marble from a box of multi-coloured marbles three times in a row	Dependent	Independent
3)	Drawing a heart from a standard deck of 52 cards twice in a row	Dependent	Independent
4)	Winning the lottery this year and next year	Dependent	Independent

Part 4 What is the probability of the following scenarios when selecting candies from a box.



	Scenario - Probability of...	Answer - Show Your Work
1)	Picking a green and then blue candy?	
2)	Picking two green candies?	
3)	Picking a red and then green candy	

Part 5 Fill in the Venn diagram with the data below

In a class of 30 students, 12 like mystery books, 17 like adventure books and 15 like both types of books.

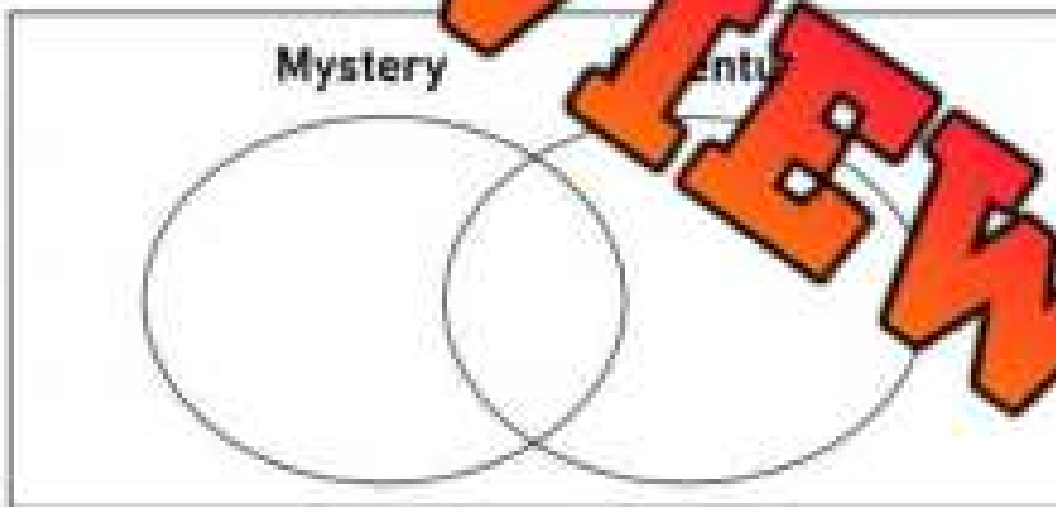

	What is the probability that a student...	Fraction	Decimal	Percent
1)	likes mystery books and not adventure books			
2)	likes adventure books			
3)	likes neither adventure nor mystery books			

Part 6 Draw a tree diagram to help you find the probability of different combinations

Dan has 9 different coloured shirts in his closet.

- 4 of the shirts are white
- 3 of the shirts are black
- 2 of the shirts are grey



Dan has 3 more days of work this week and he wants to plan which shirts he will wear. He pulls out 3 shirts randomly as he is in a hurry.

1) Draw a tree diagram to represent the scenario above.

PREVIEW

2) How many combinations of shirts could he draw? _____

3) What is the probability of taking out...	Fraction	Percent
a) a white, then black, then grey shirt?		
b) three black shirts?		
c) a white shirt, and then two black shirts?		